



Moving Toward Energy Efficient Access Networks

Bart Lannoo, IBBT, Belgium (Bart.Lannoo@intec.ugent.be)

Peter Vetter, Bell Labs, Alcatel-Lucent, US (Peter.Vetter@alcatel-lucent.com)



Bell Labs

GreenTouch Wireline Access

50x reduction power per user / 500x efficiency gain

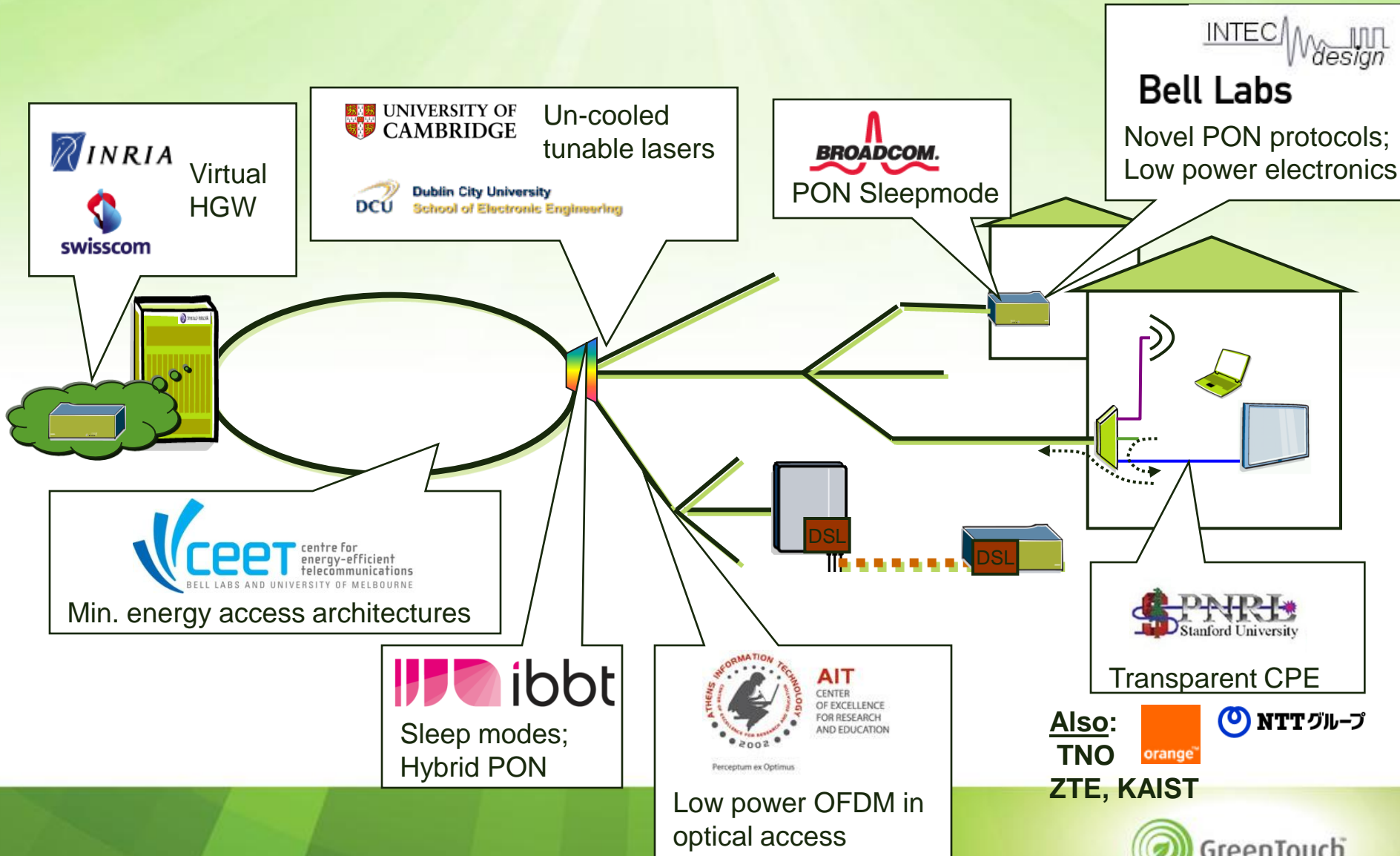

Why is energy reduction of fixed broadband important?

- Fixed Broadband is an important part of the total carbon footprint of ICT
- Lower power reduces cost
 - Reduces OPEX
 - Allows for higher density, hence reduced floorspace
 - 2x for additional consumption (supply, cooling)
 - Reduces back-up battery
 - Alternative supplies in remotes (e.g. reverse power feed via DSL)

2020
100% = 349
MtCO₂e

- Mobile (179 MtCO₂e)
- Fixed narrowband (70 MtCO₂e)
- Telecom devices (51 MtCO₂e)
- Fixed broadband (49 MtCO₂e)

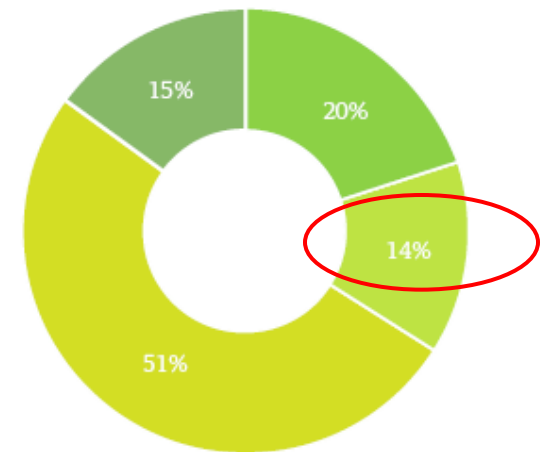

49 MtCO₂e

Dissipation in Current Fixed Access

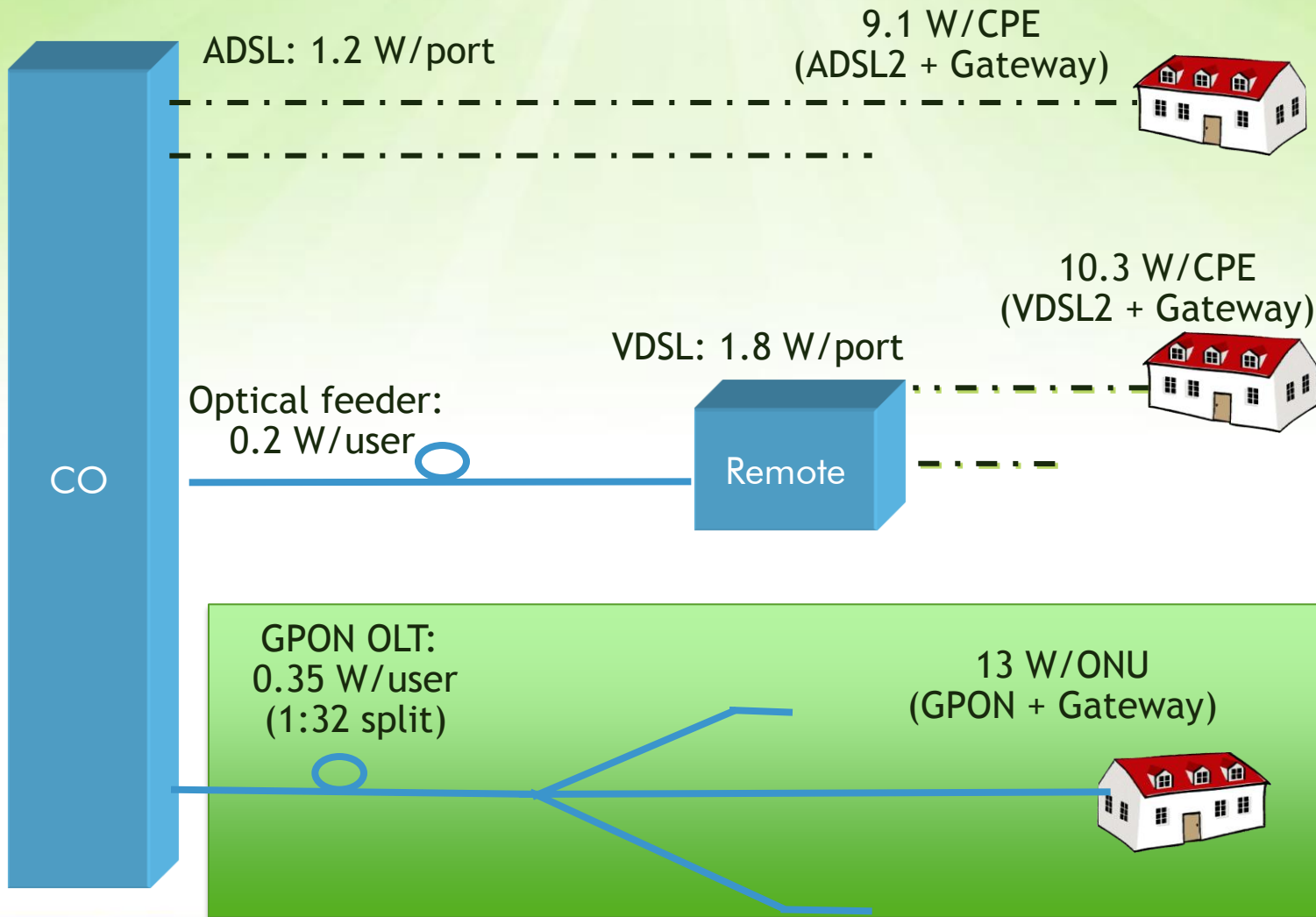

Focus of this presentation

(Upper bound values from EU CoC – CPE includes 4xFE, WiFi, and voice)

GPON Improvements - GreenTouch roadmap

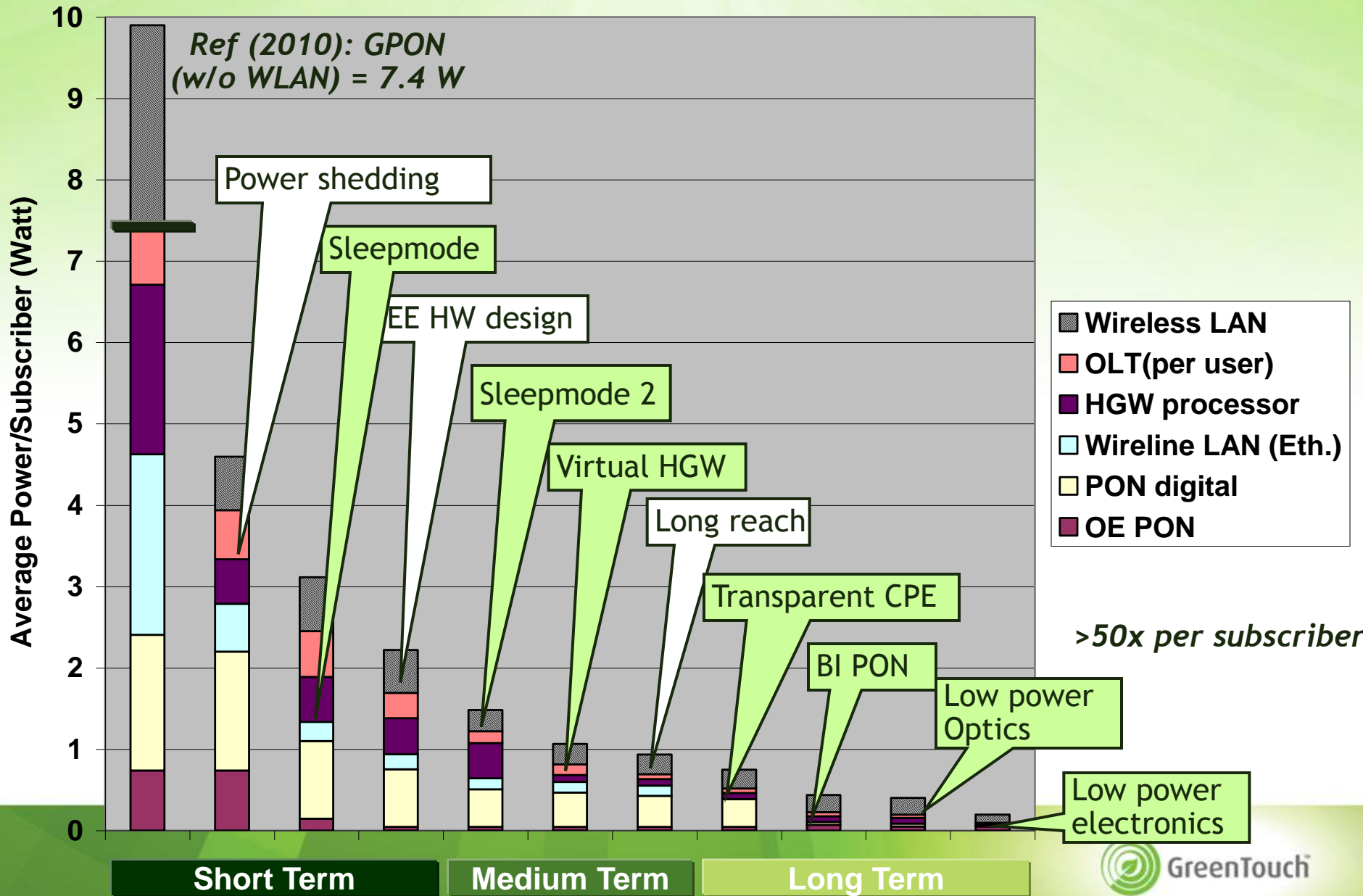

Energy Saving Techniques

- Short term
 - Sleep modes
 - Energy Efficient Hardware design
- Medium term
 - Sleep modes 2
 - Virtual Home Gateway
 - Long reach access
- Long term
 - Bit-Interleaving PON
 - Transparent CPE
 - Low power electronics and optics

Fast Sleep Mode

- Aim for awake time ONU proportional to useful payload
- Challenges
 - Schedule probing cycles and awake time with minimum impact on QoE
 - Minimize power during sleep state
 - Minimize fast wake-up

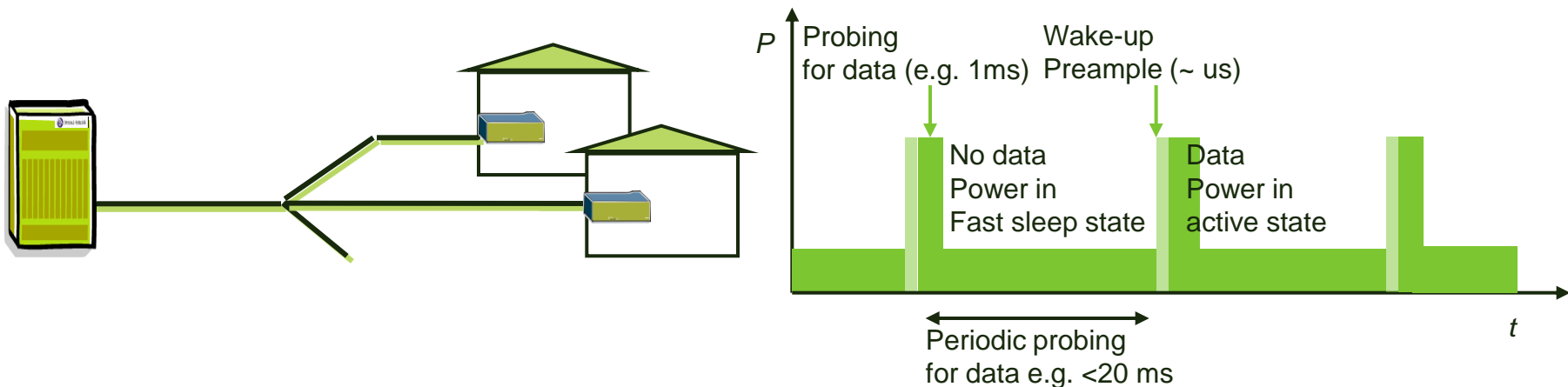

ONU Power Consumption Model (Active)

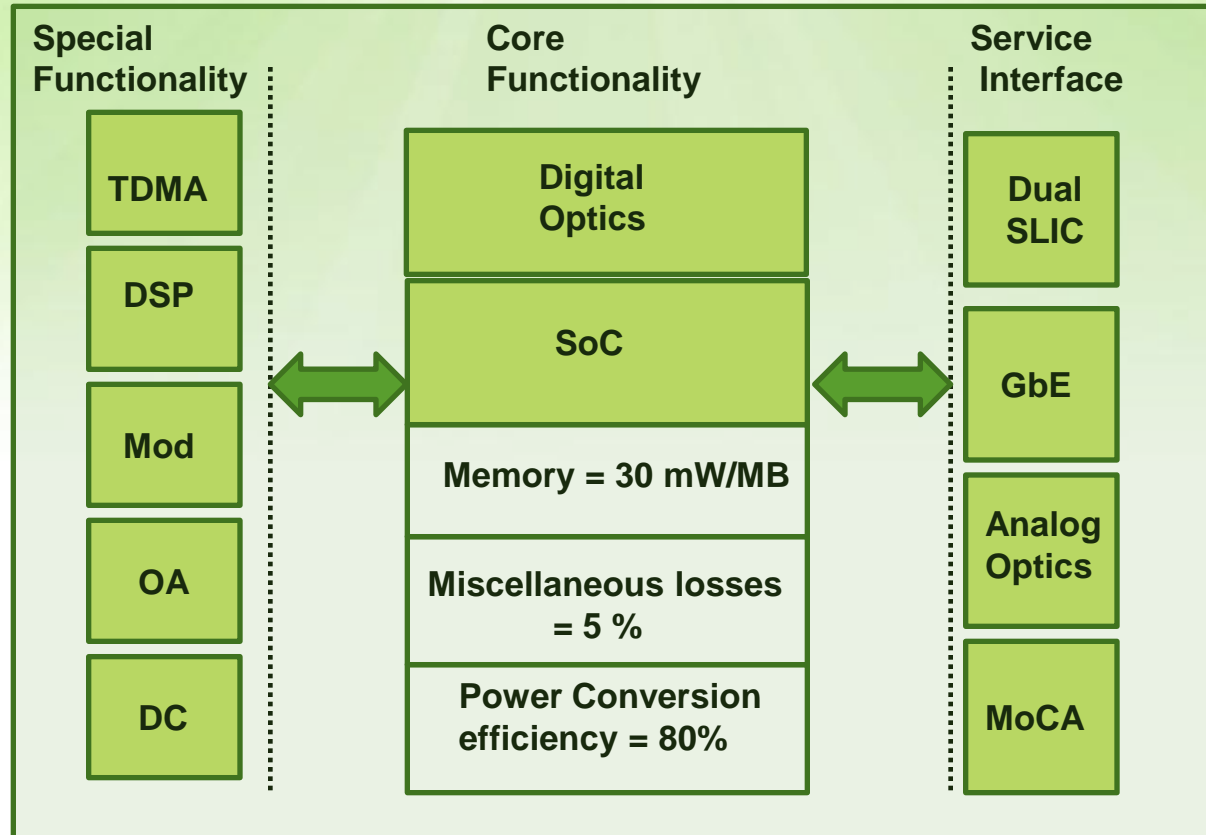

Special functionality may be required for some system concepts and may not be for others.

TDMA: Time Division Multiple Access; DSP: Digital Signal Processing; Mod: Modulator; OA: Optical Amplification; DC: Dispersion Compensation; SoC: System on Chip; SLIC: Subscriber Line Interface Circuit; GbE: Gigabit Ethernet; MoCA: Multimedia over Coaxial Alliance

ONU Power Consumption Model (Power Shedding)

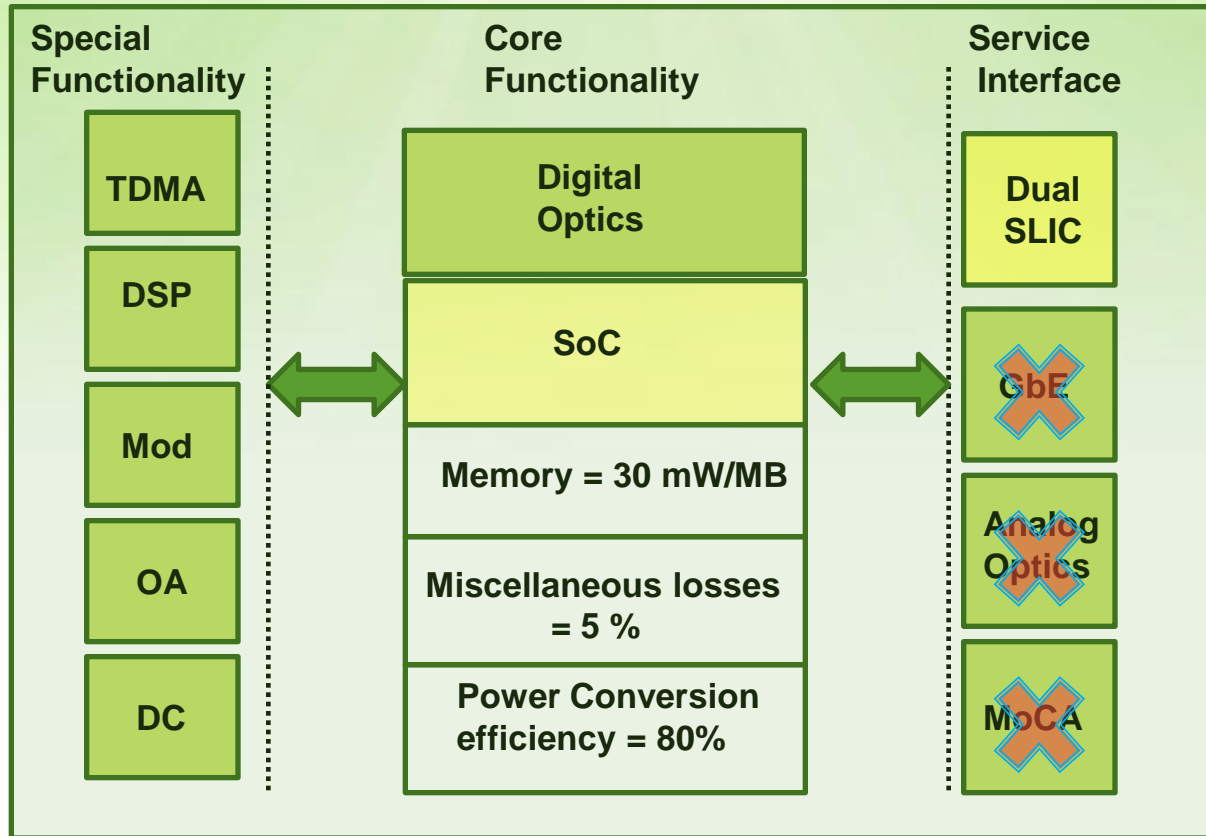

: Component not used



: Low activity (in SLICs due to no on-hook transmission; SoC: due to reduced processing speed)

ONU Power Consumption Model (Doze state)

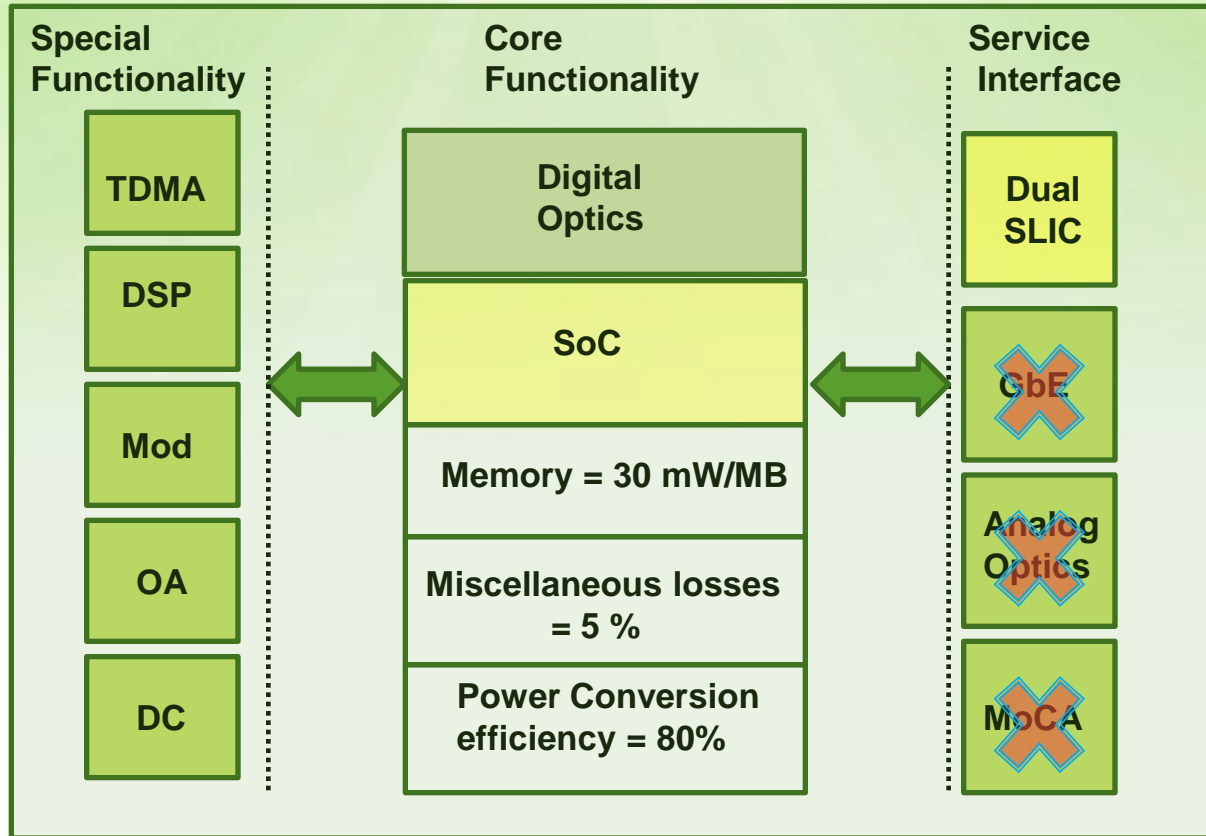

: Component not used



: Low activity (in SLICs due to no on-hook transmission; SoC: due to reduced processing speed)



:50 % power savings

ONU Power Consumption Model (Sleep state)

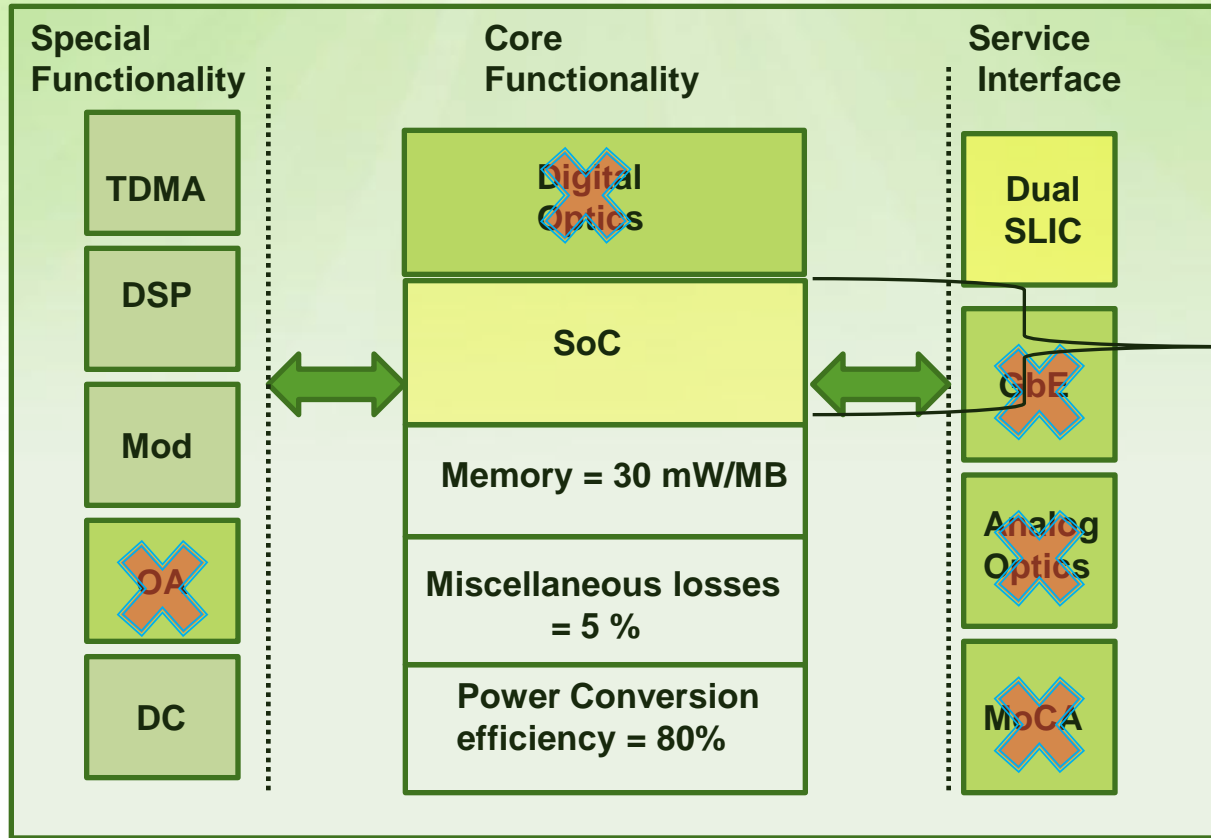

Note that the SoC power consumption will further reduce compared to doze state due to even reduced processing



: Component not used



: Low activity (in SLICs due to no on-hook transmission; SoC: due to reduced processing speed)

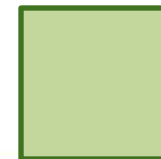

:50 % power savings

ONU Power Consumption in Different States

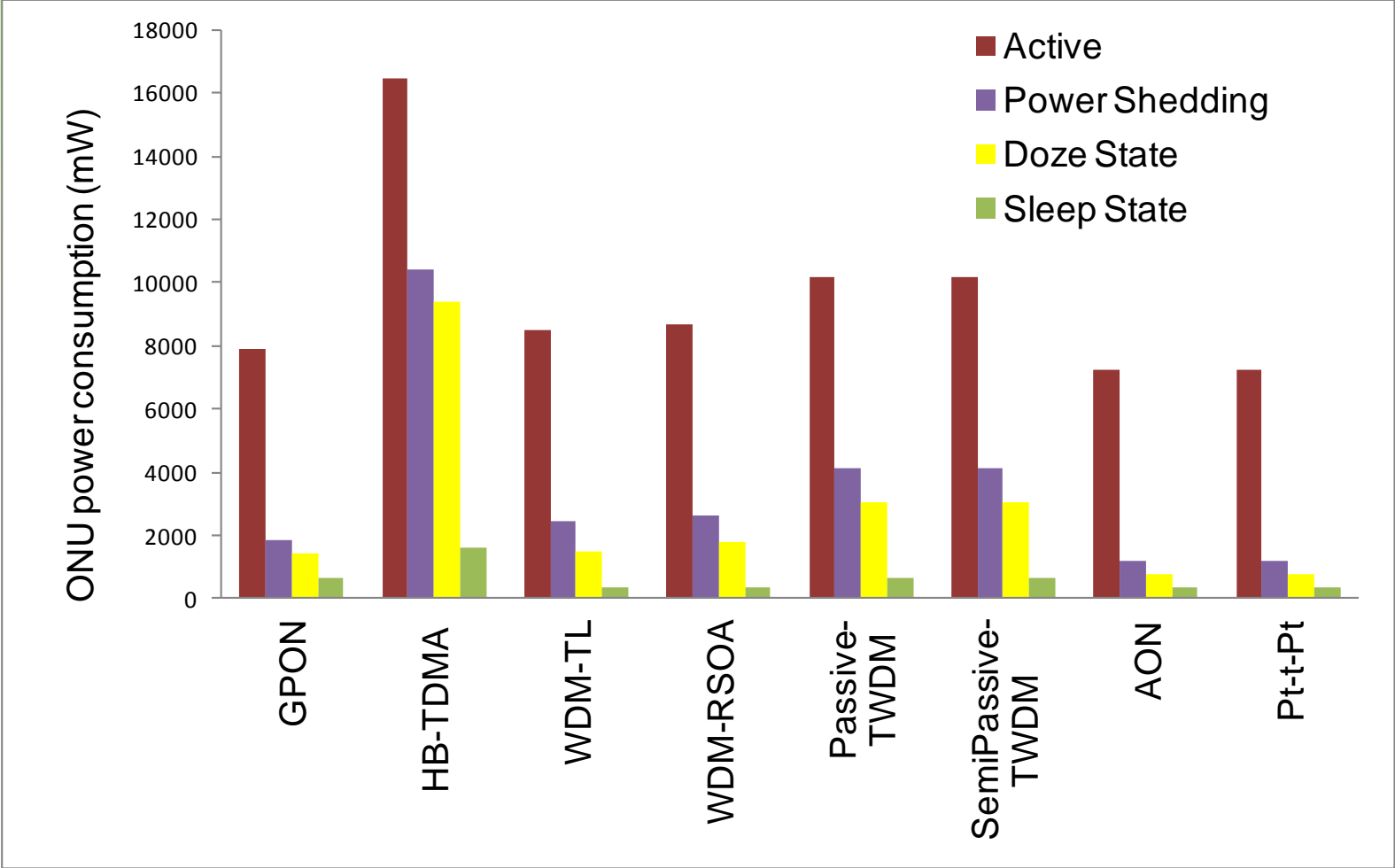

Wireline access PON improvements

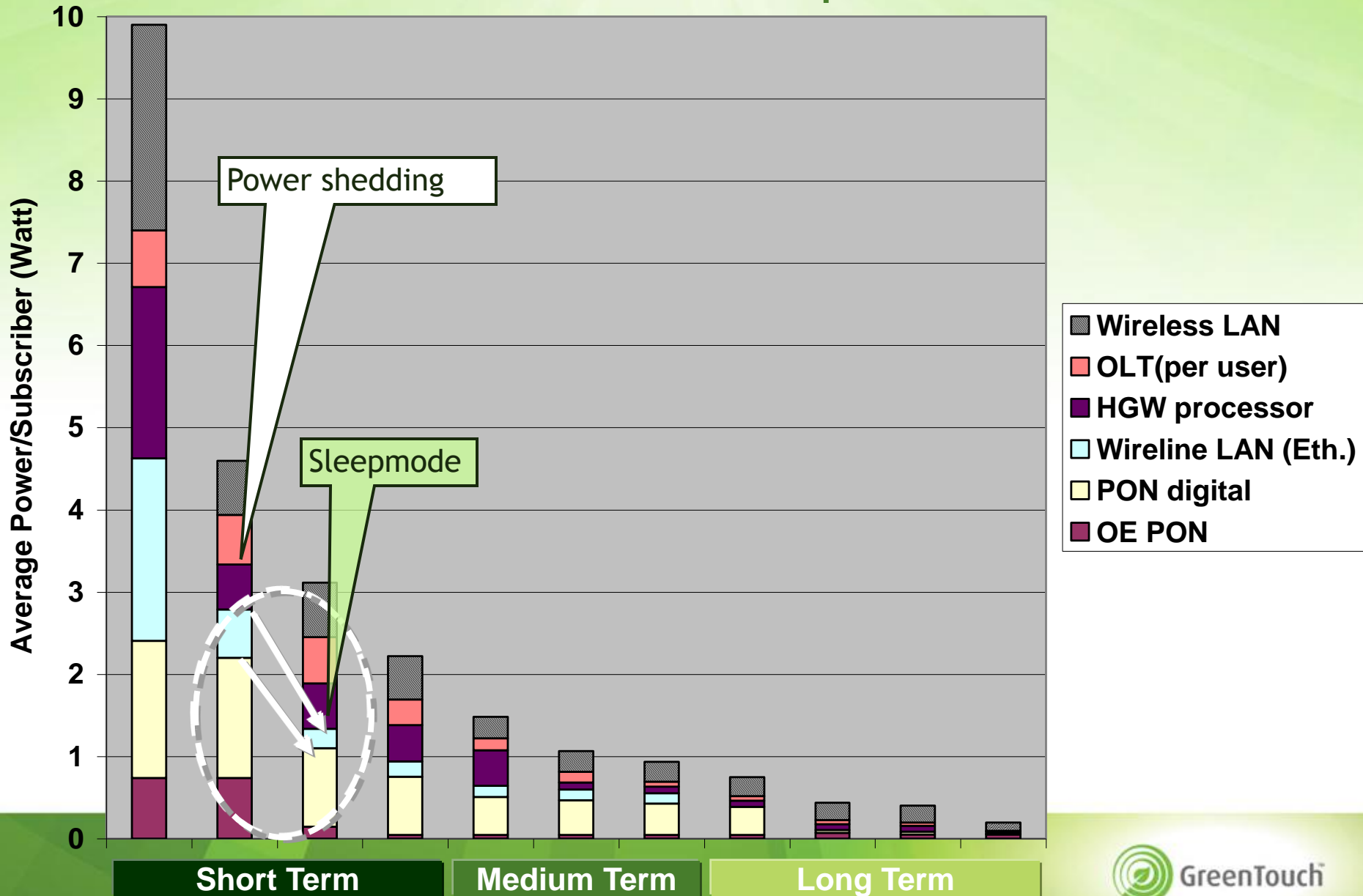

Energy Saving Techniques

- Short term
 - Sleep modes
 - Energy Efficient Hardware design
- Medium term
 - Sleep modes 2
 - Virtual Home Gateway
 - Long reach access
- Long term
 - Bit-Interleaving PON
 - Transparent CPE
 - Low power electronics and optics

Virtual Home Gateway / Quasi-passive CPE

- Transparent CPE providing connectivity in-house and to network
 - Functions of current CPE moved to virtual HGW in network
 - Low power connectivity (“quasi-passive”) or transparent (“passive”) CPE
- Savings:
 - Cut-through of high bitrate services to terminal: LAN interfaces on CPE
 - Lower power by processor platform sharing
 - *>5x reduction per subscriber demonstrated*

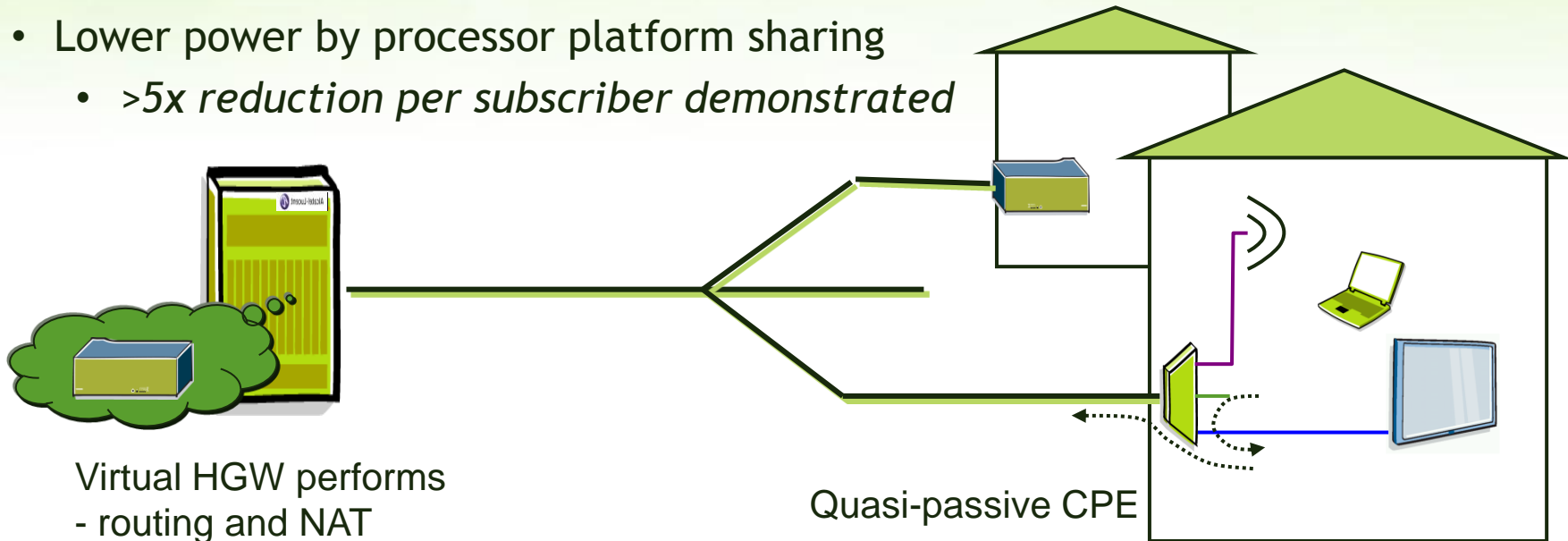

Virtual HGW performs

- routing and NAT
- firewalling
- OAM management

Quasi-passive CPE

Wireline Access Improvements

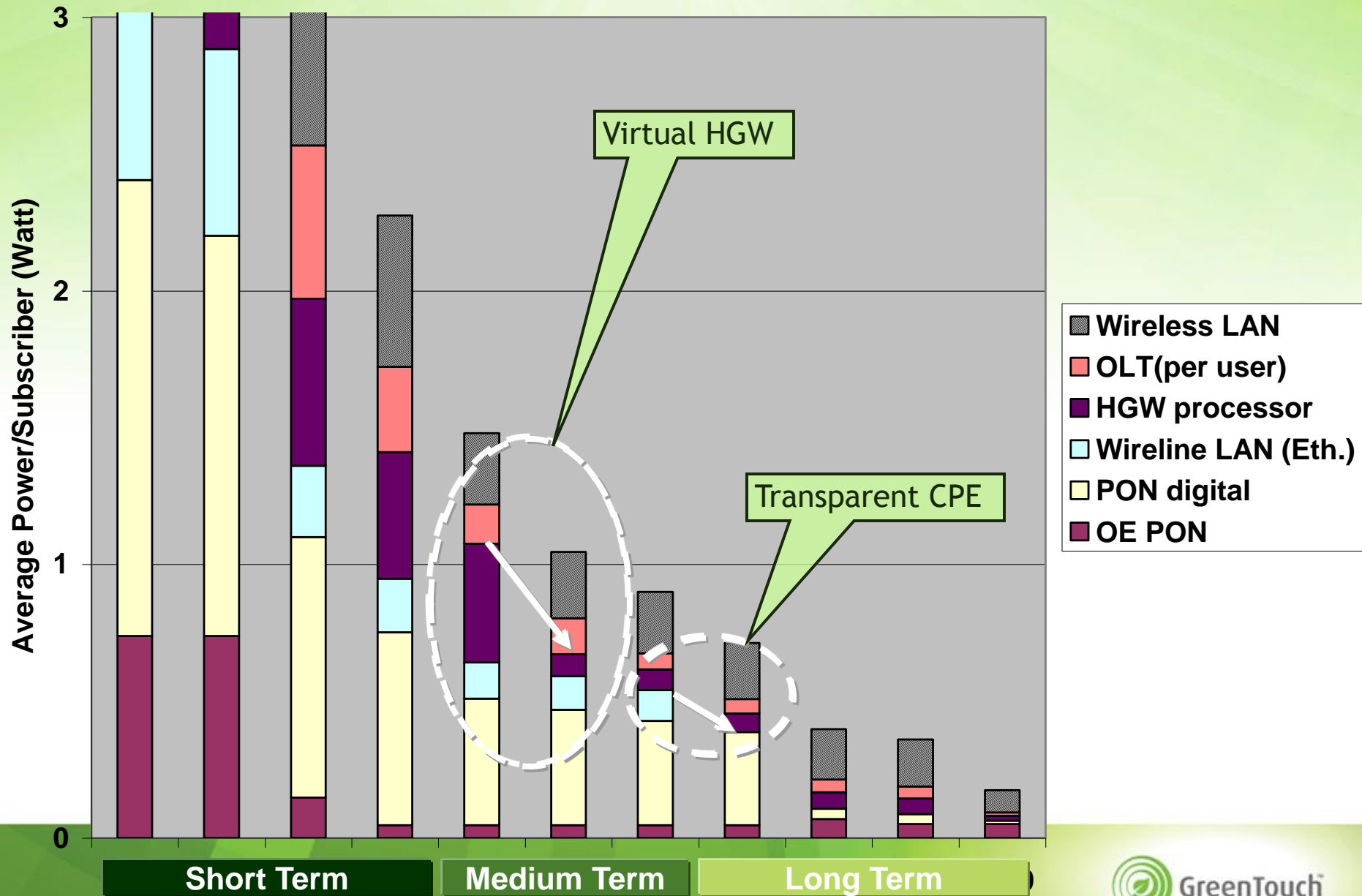

Energy Saving Techniques

- Short term
 - Sleep modes
 - Energy Efficient Hardware design
- Medium term
 - Sleep modes 2
 - Virtual Home Gateway
 - Long reach access
- Long term
 - Bit-Interleaving PON
 - Transparent CPE
 - Low power electronics and optics

Standard XG-PON

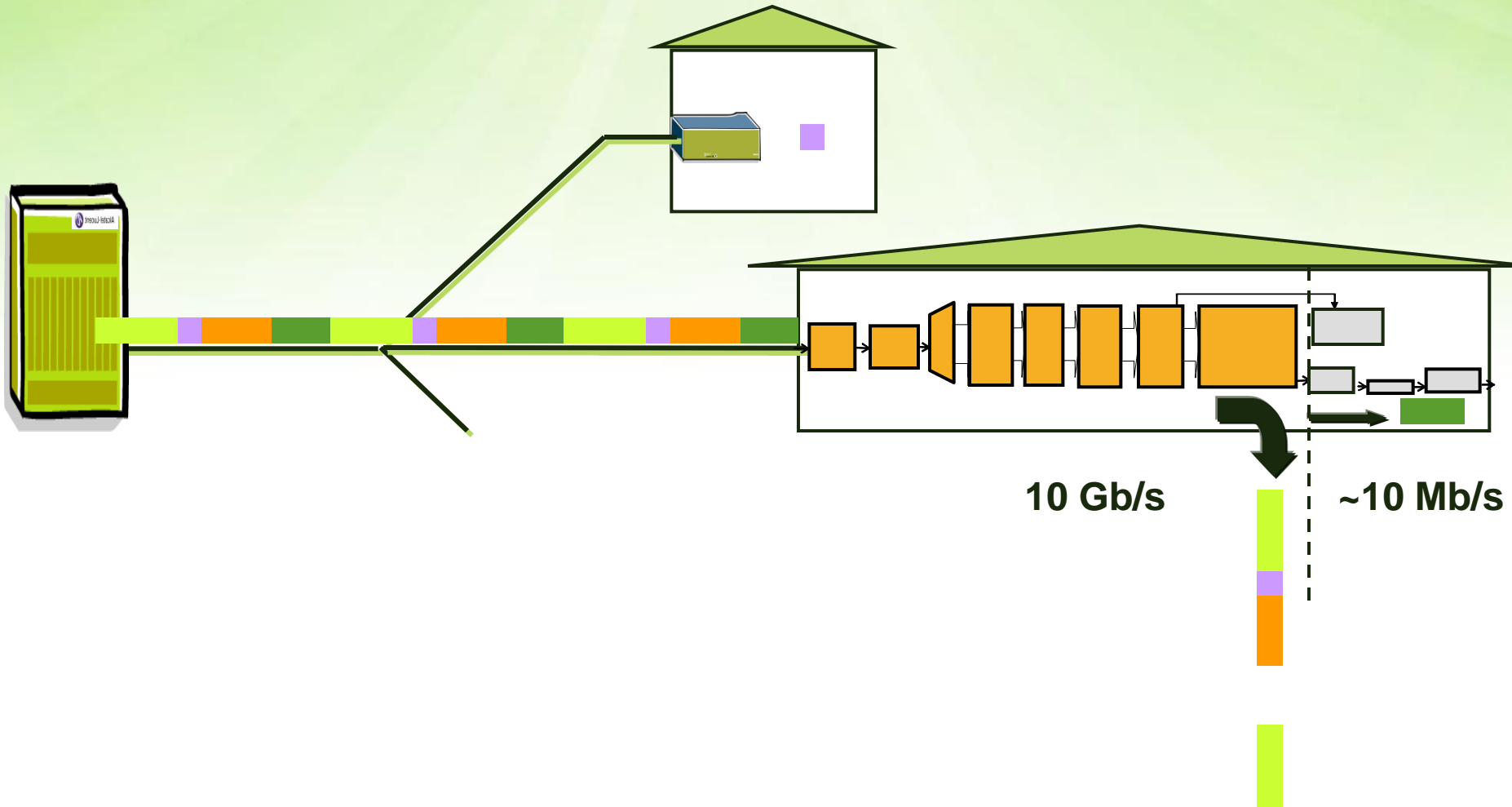

Bit-Interleaving PON

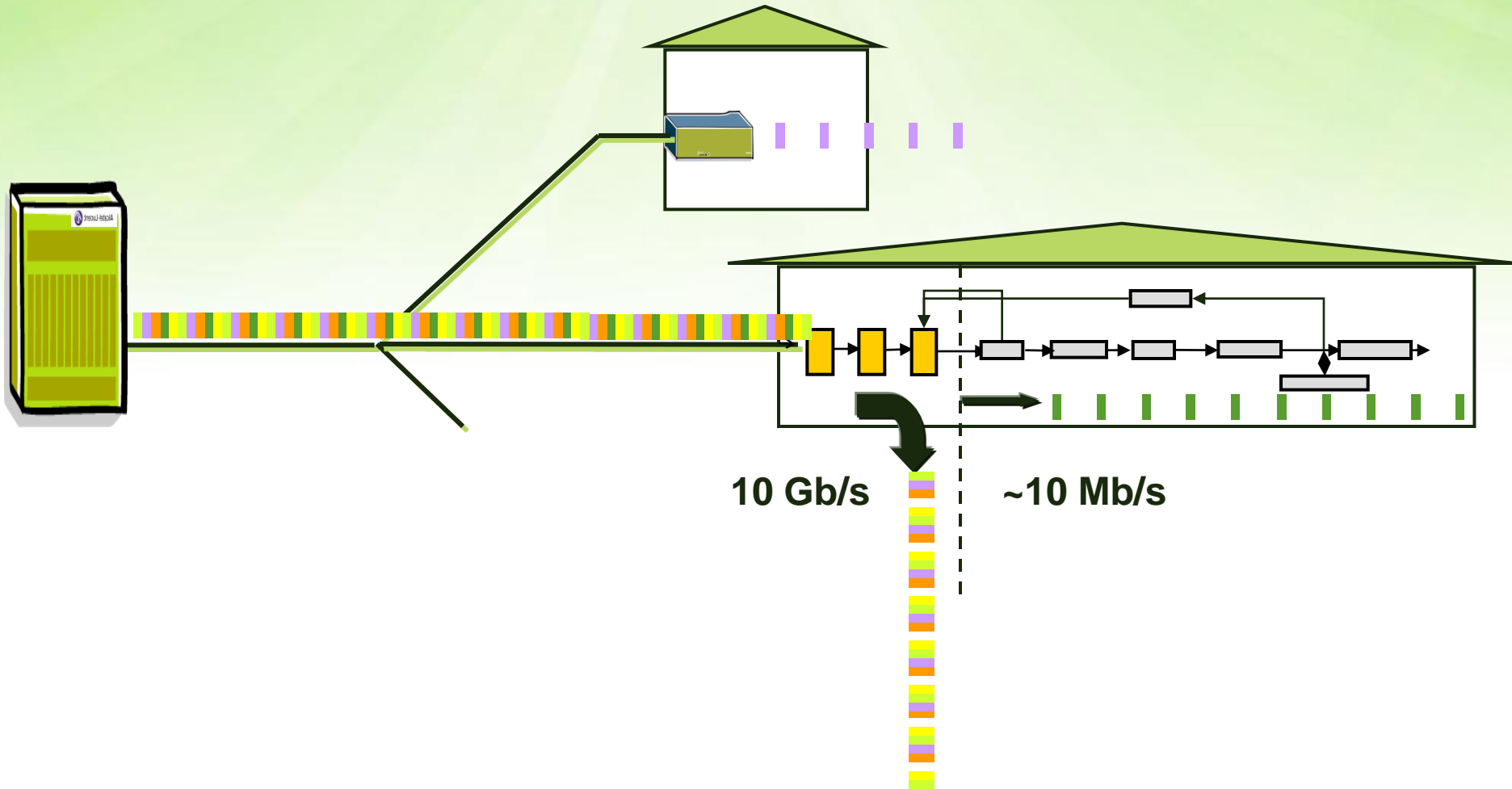

Demonstrator

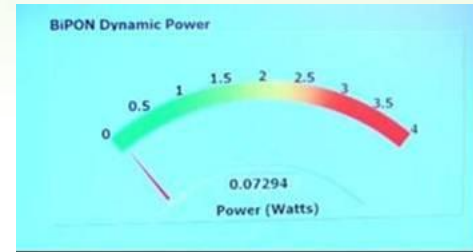
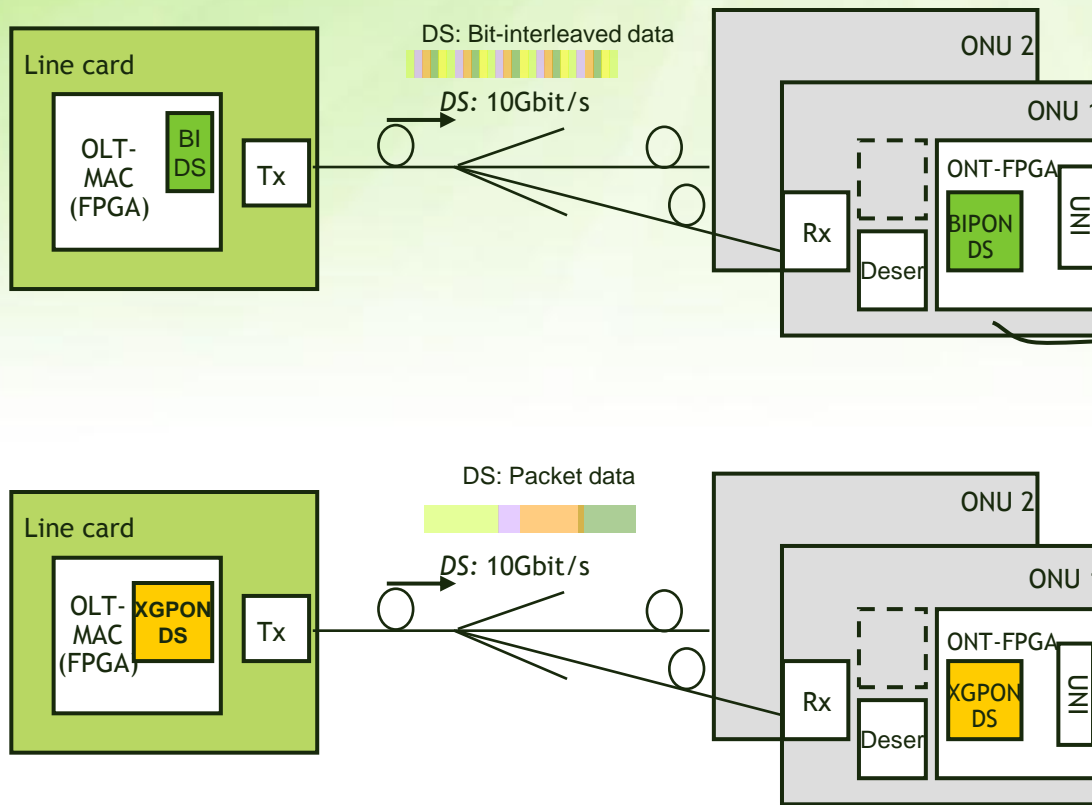

More than order of magnitude better efficiency of MAC electronics for Bi-PON than XG-PON in cyclic sleep mode !

Bell Labs

INTEC design



Link to video about the press release and demo
<http://www.greentouch.org/index.php?page=Bi-PON>



Wireline Access Improvements

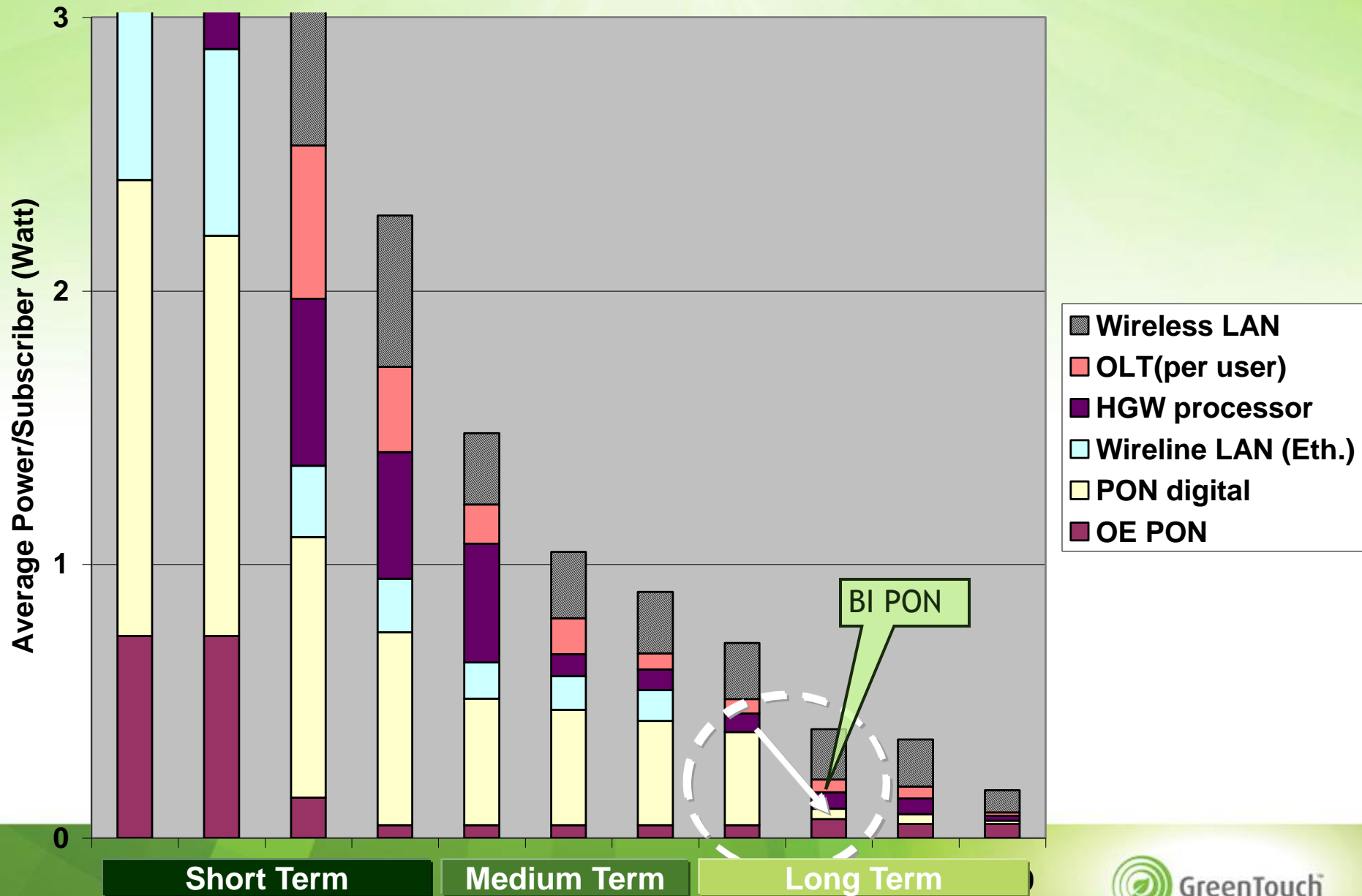

Conclusion: Wireline Access Energy efficiency

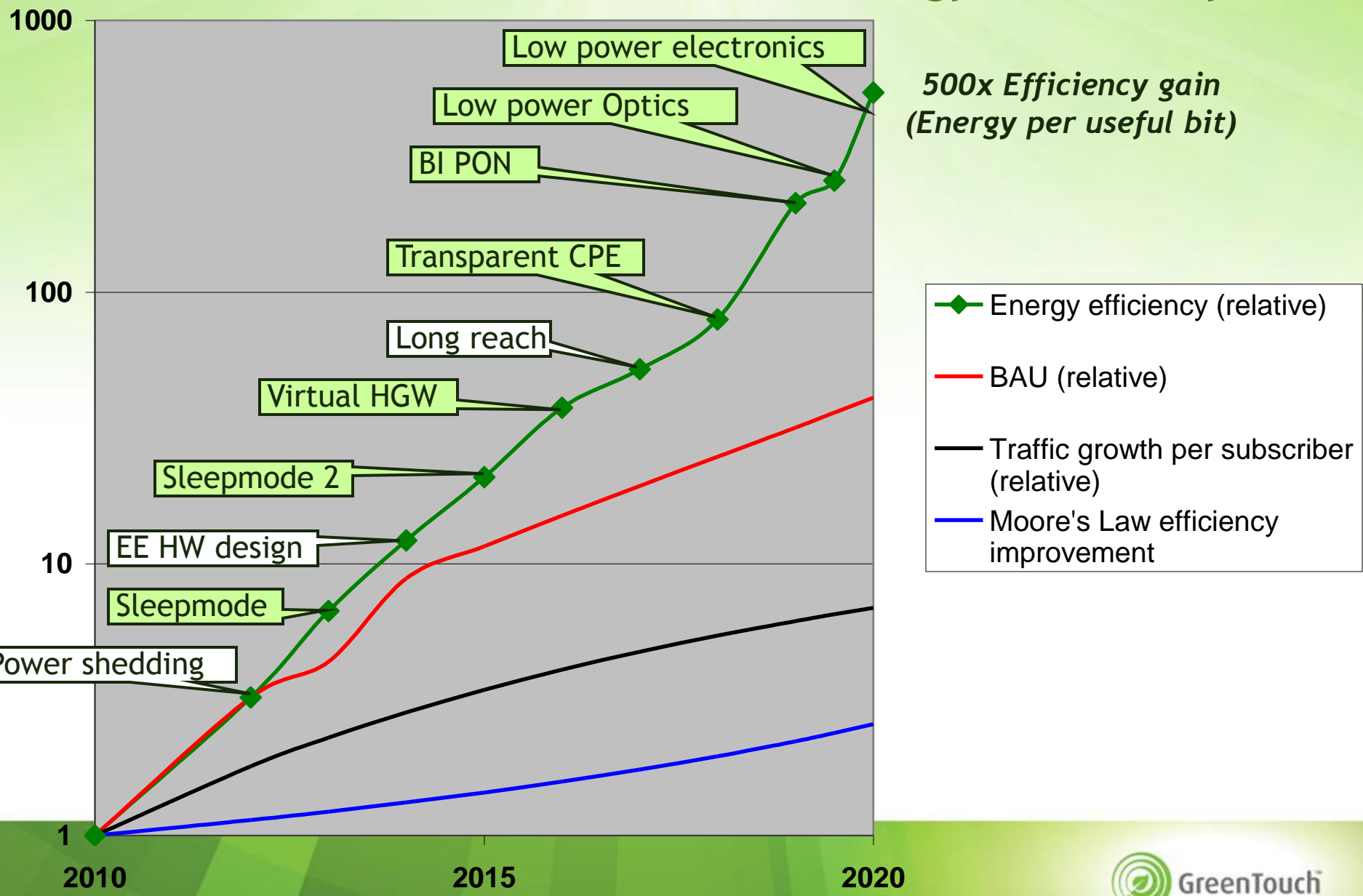



<http://www.greentouch.org>

<http://www.ict-oase.eu>

***Thanks for your Attention..
Any Questions?***

Peter Vetter

Peter.Vetter@alcatel-lucent.com

Bart Lannoo

Bart.Lannoo@intec.ugent.be

Tel.: (+32) 9 33 14998