



GreenTouch™

Moving Toward Energy Efficient Access Networks

Peter.Vetter@alcatel-lucent.com

GreenTouch Wireline Access

50x reduction power per user / 500x efficiency gain

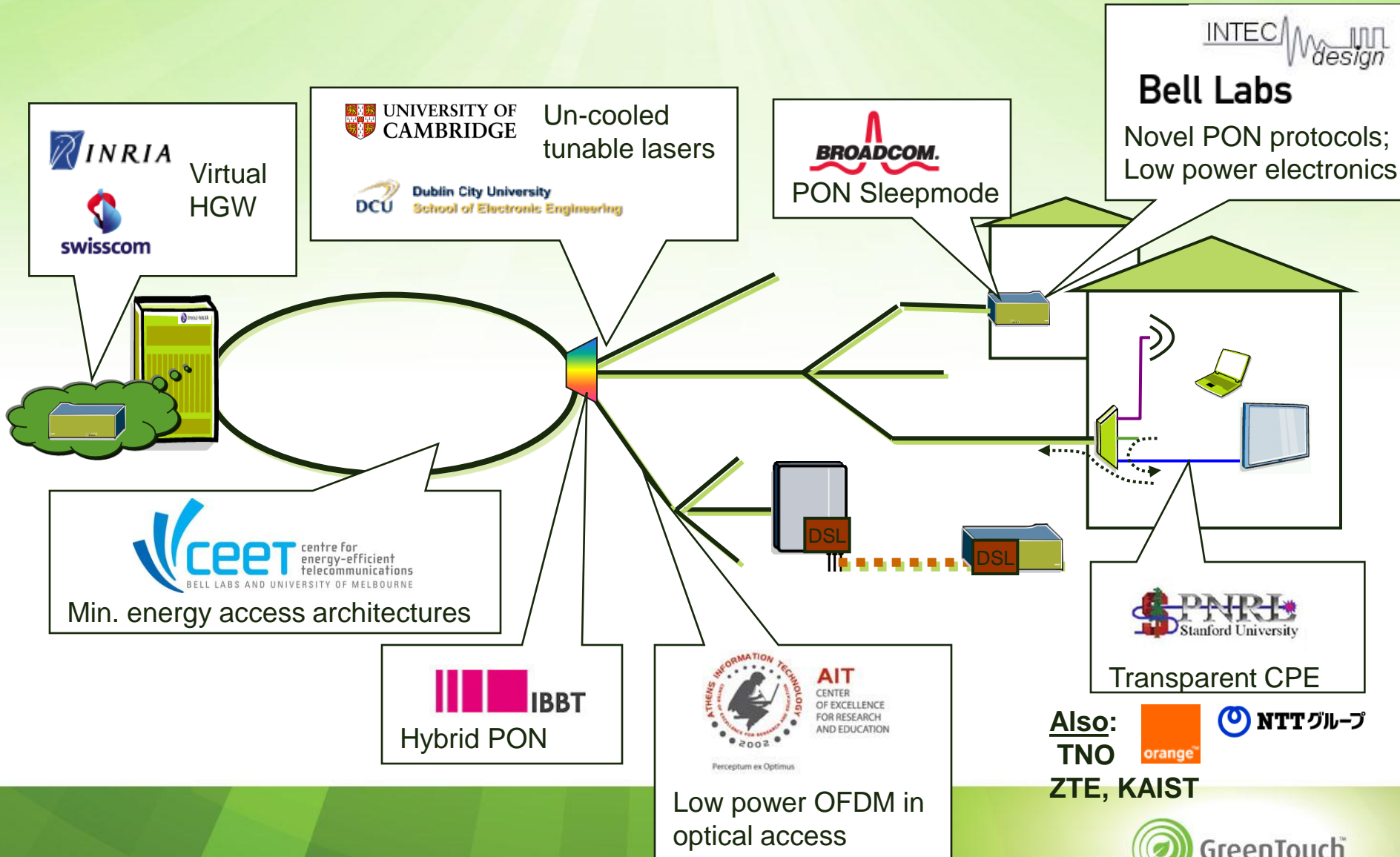

Why is energy reduction of fixed broadband important?

- Fixed Broadband is an important part of the total carbon footprint of ICT
- Lower power reduces cost
 - Reduces OPEX
 - Allows for higher density, hence reduced floorspace
 - 2x for additional consumption (supply, cooling)
 - Reduces back-up battery
 - Alternative supplies in remotes (e.g. reverse power feed via DSL)

2020
100% = 349
MtCO₂e

- Mobile (179 MtCO₂e)
- Fixed narrowband (70 MtCO₂e)
- Telecom devices (51 MtCO₂e)
- Fixed broadband (49 MtCO₂e)

49 MtCO₂e

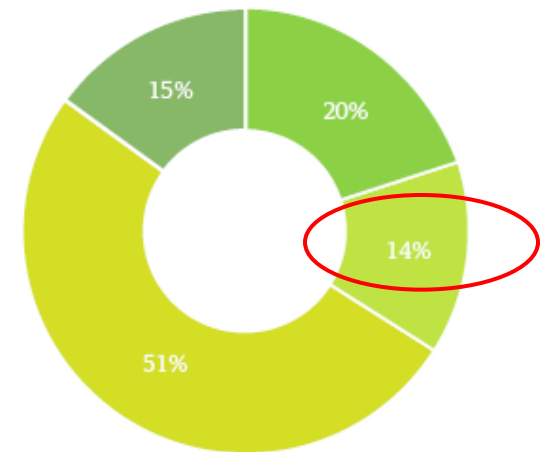

Dissipation in Current Fixed Access

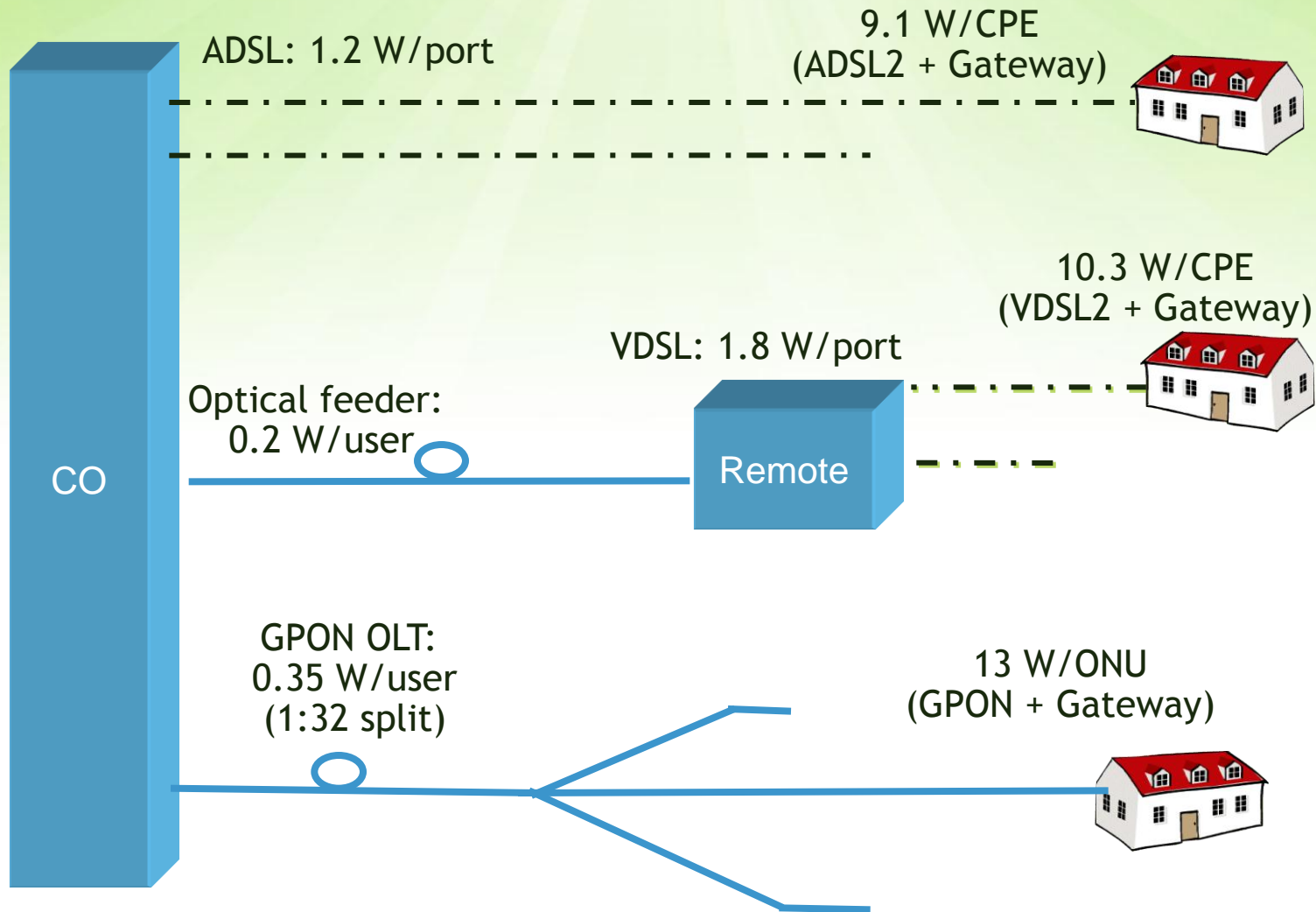

(Upper bound values from EU CoC – CPE includes 4xFE, WiFi, and voice))

DSL Energy saving approach

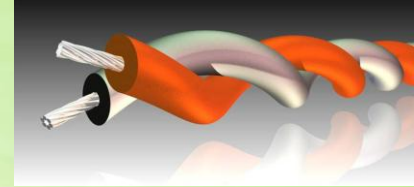

- Large part of power dissipation is in line driver
- Reductions
 - New line driver design
 - Spectral management with power consumption as constraint

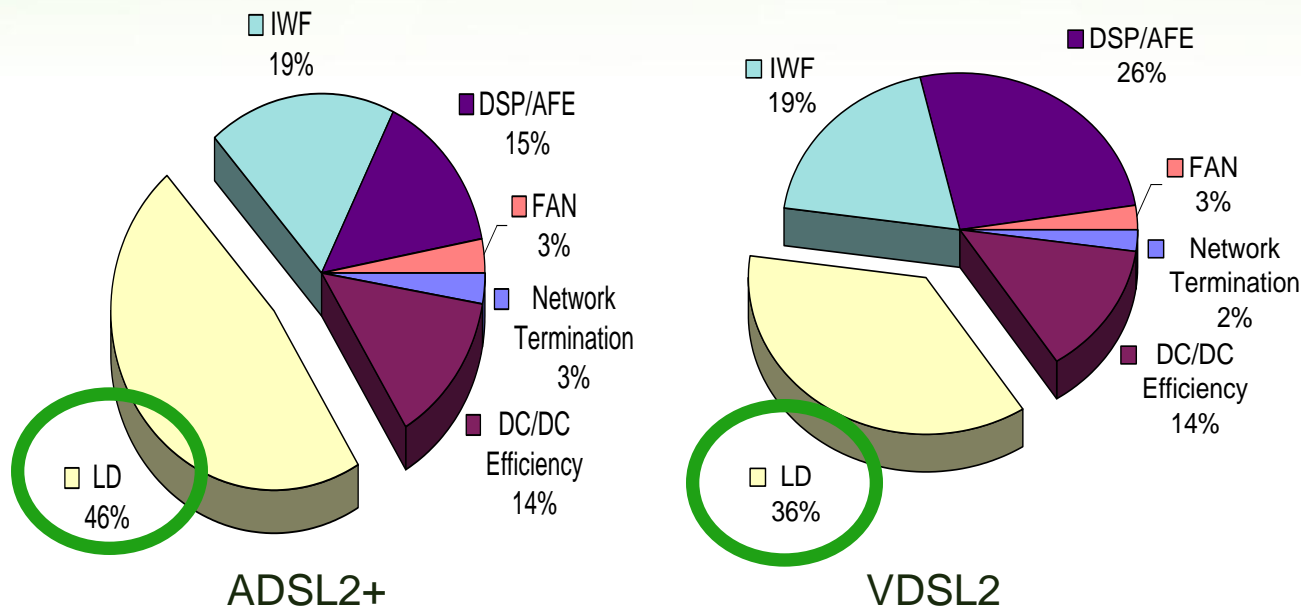

DSL Energy saving approach (2)

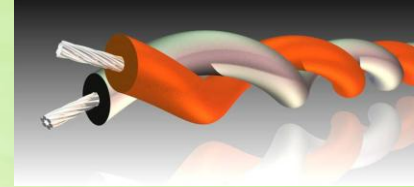

Use line driver design to reduce energy consumption for given transmit power => 2x

Use power spectrum optimization to minimize required transmit power => 2x for only small reduction in rate

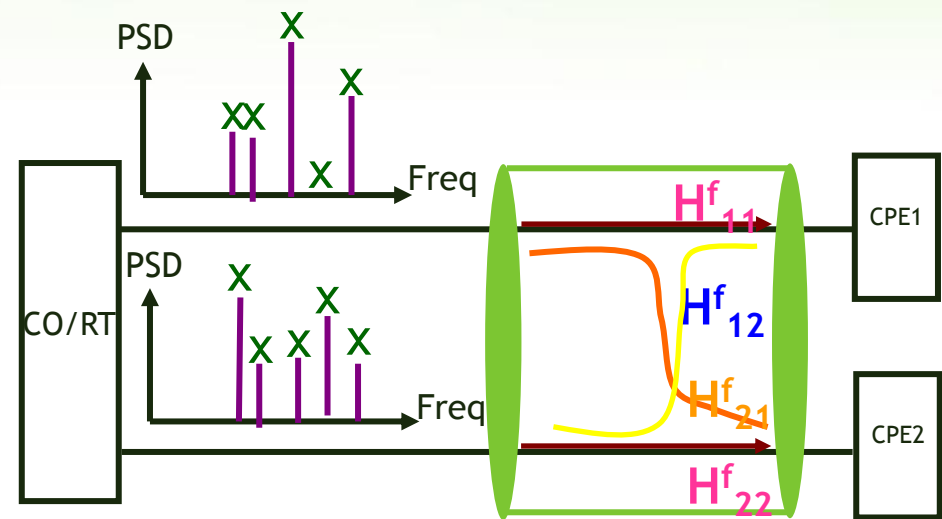
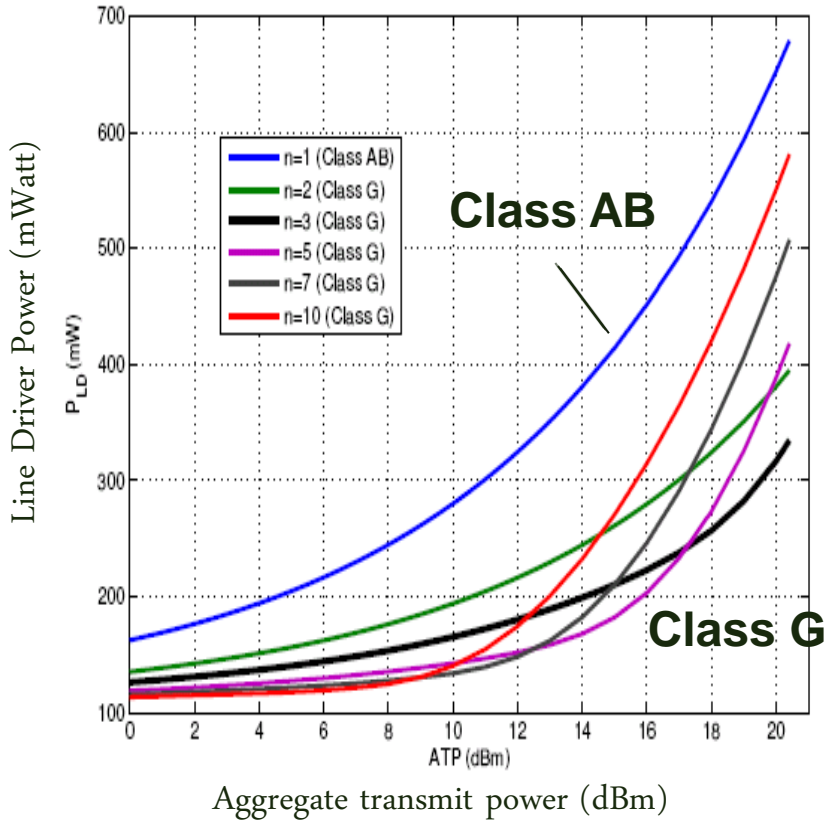

GPON Improvements - GreenTouch roadmap

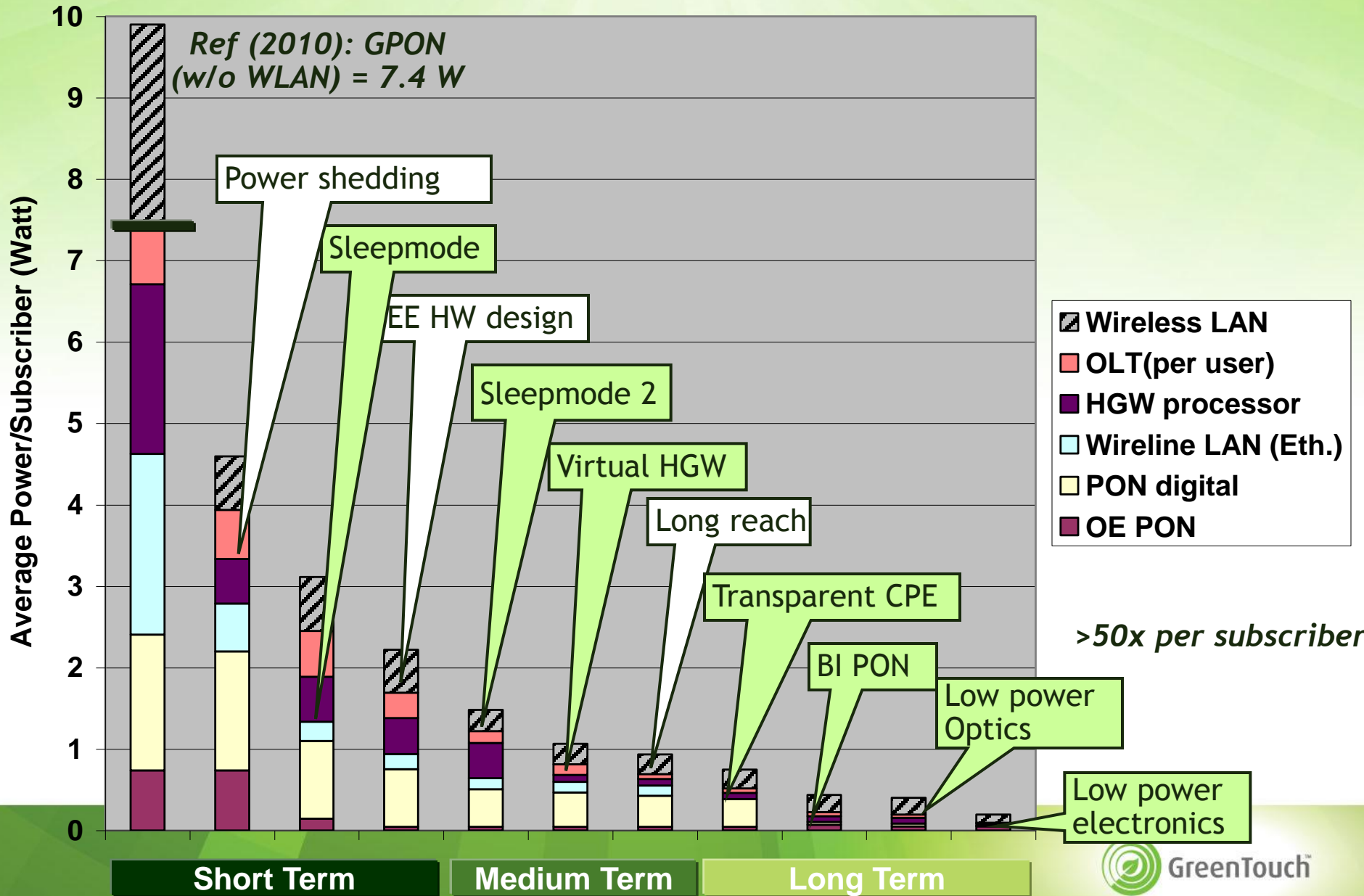

Fast Sleep Mode

- Aim for awake time ONU proportional to useful payload
- Challenges
 - Schedule probing cycles and awake time with minimum impact on QoE
 - Minimize power during sleep state
 - Minimize fast wake-up

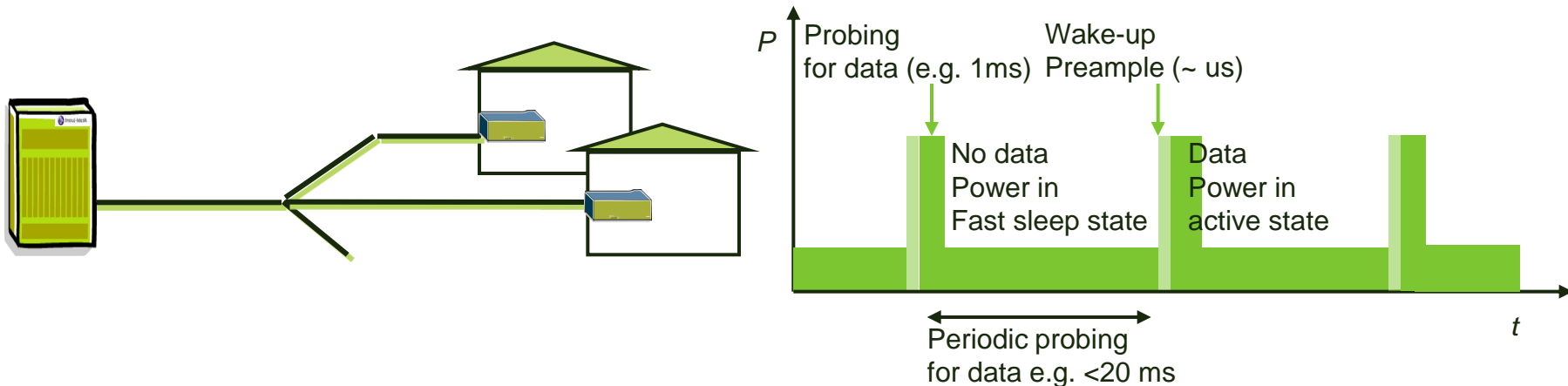

Wireline access PON improvements

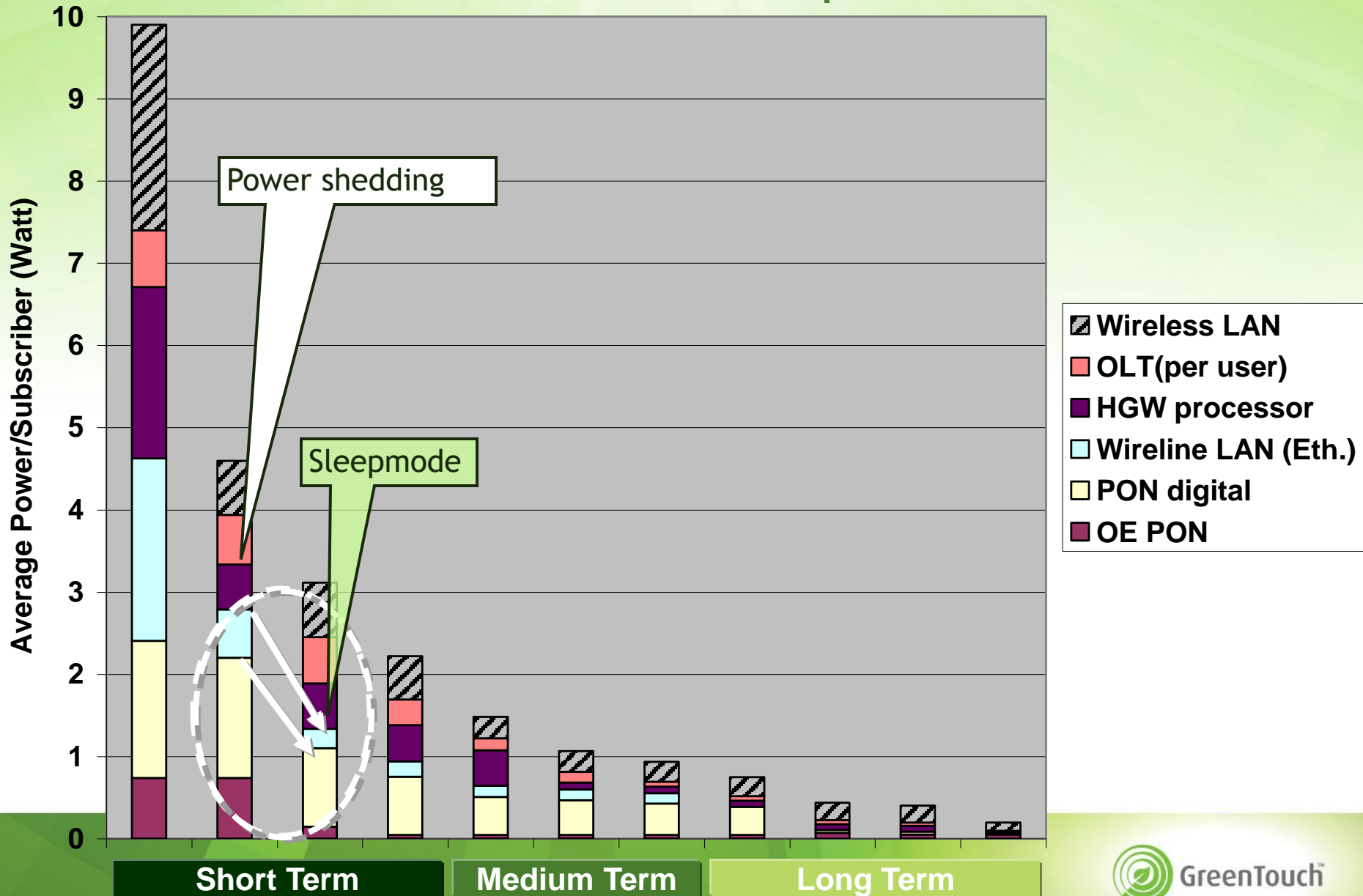

Standard XG-PON

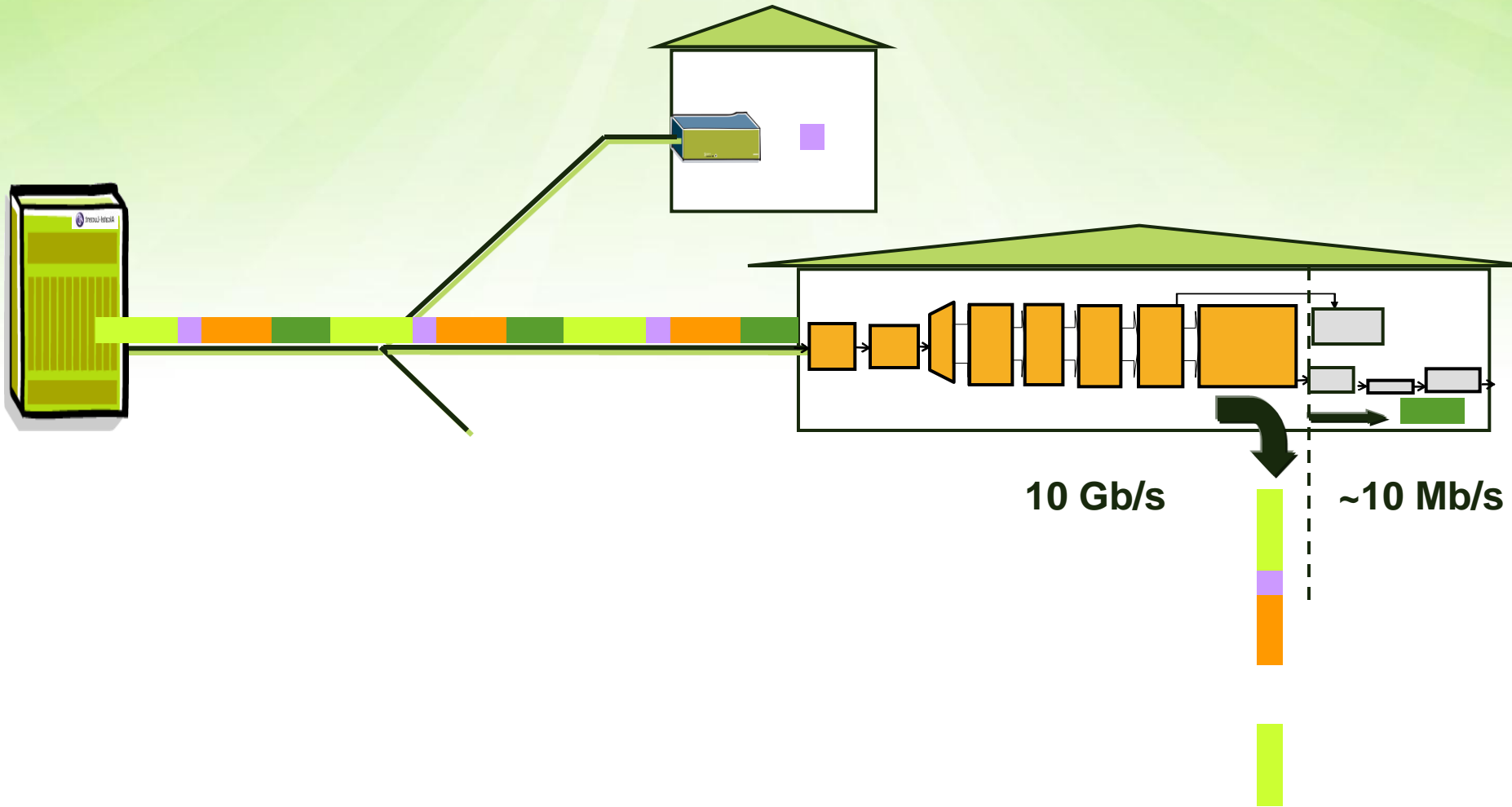

Bit-Interleaving PON

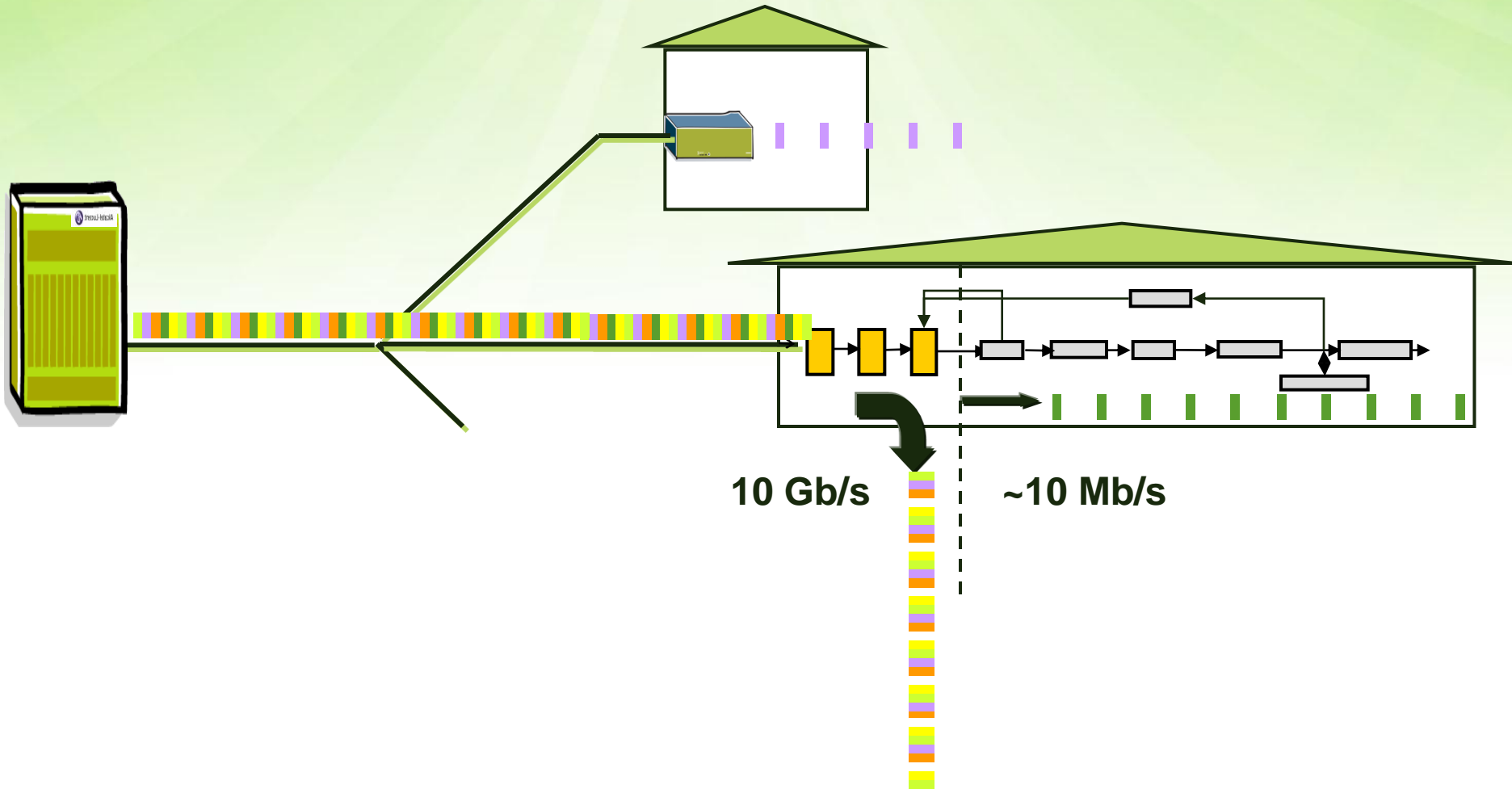

Demonstrator

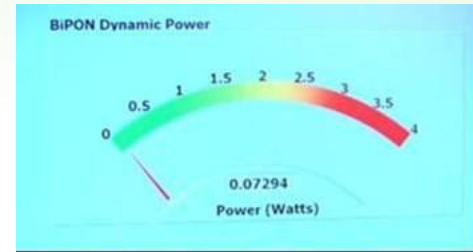
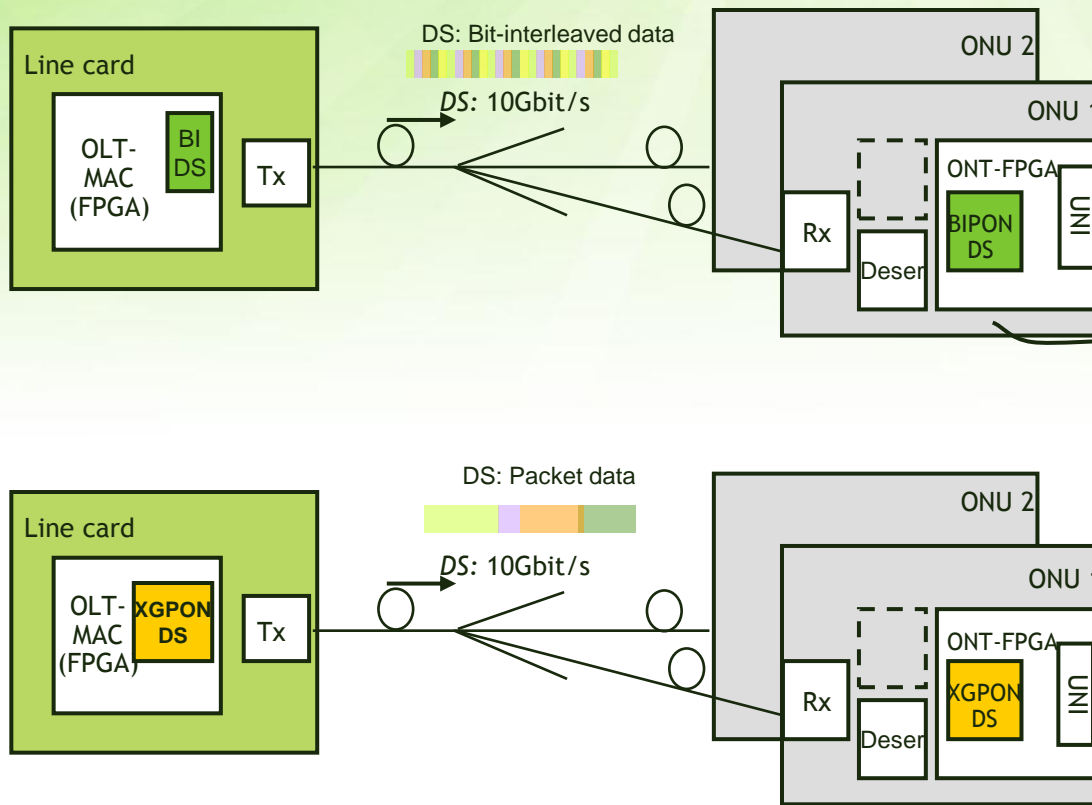

More than order of magnitude better efficiency of MAC electronics for Bi-PON than XG-PON in cyclic sleep mode !

Bell Labs

INTEC design



Link to video about the press release and demo
<http://www.greentouch.org/index.php?page=Bi-PON>



Wireline Access Improvements

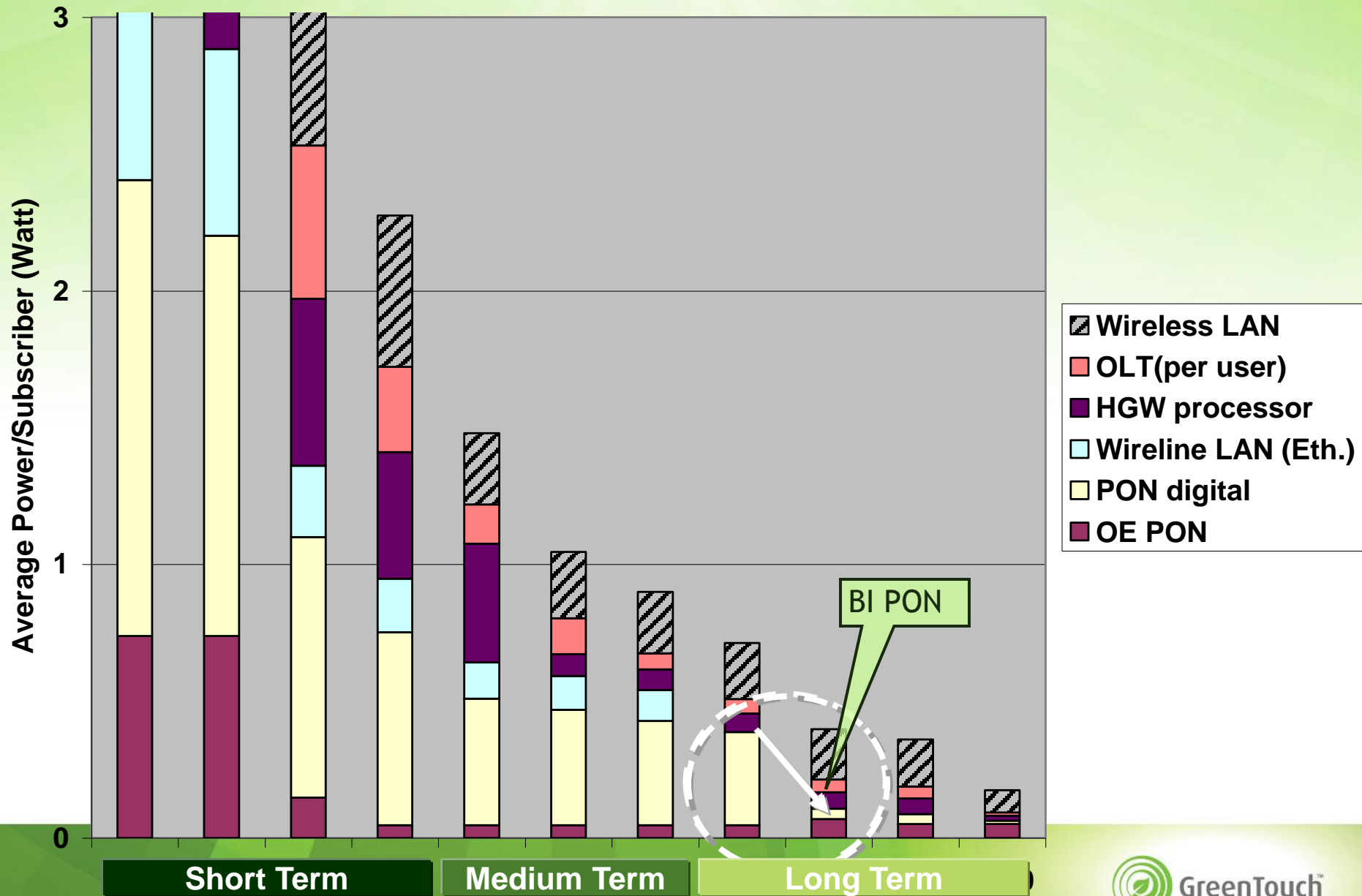

Virtual Home Gateway / Quasi-passive CPE

- Transparent CPE providing connectivity in-house and to network
 - Functions of current CPE moved to virtual HGW in network
 - Low power connectivity (“quasi-passive”) or transparent (“passive”) CPE
- Savings:
 - Cut-through of high bitrate services to terminal: LAN interfaces on CPE
 - Lower power by processor platform sharing
 - *>5x reduction per subscriber demonstrated*

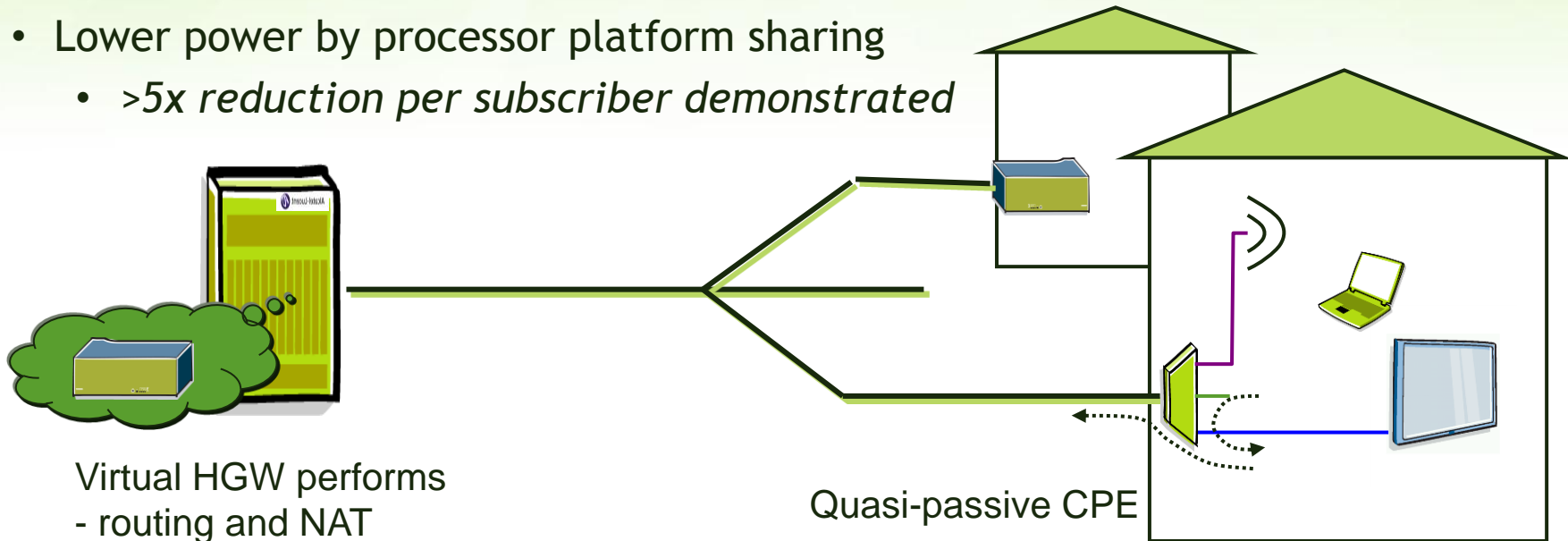

Virtual HGW performs

- routing and NAT
- firewalling
- OAM management

Quasi-passive CPE

Wireline Access Improvements

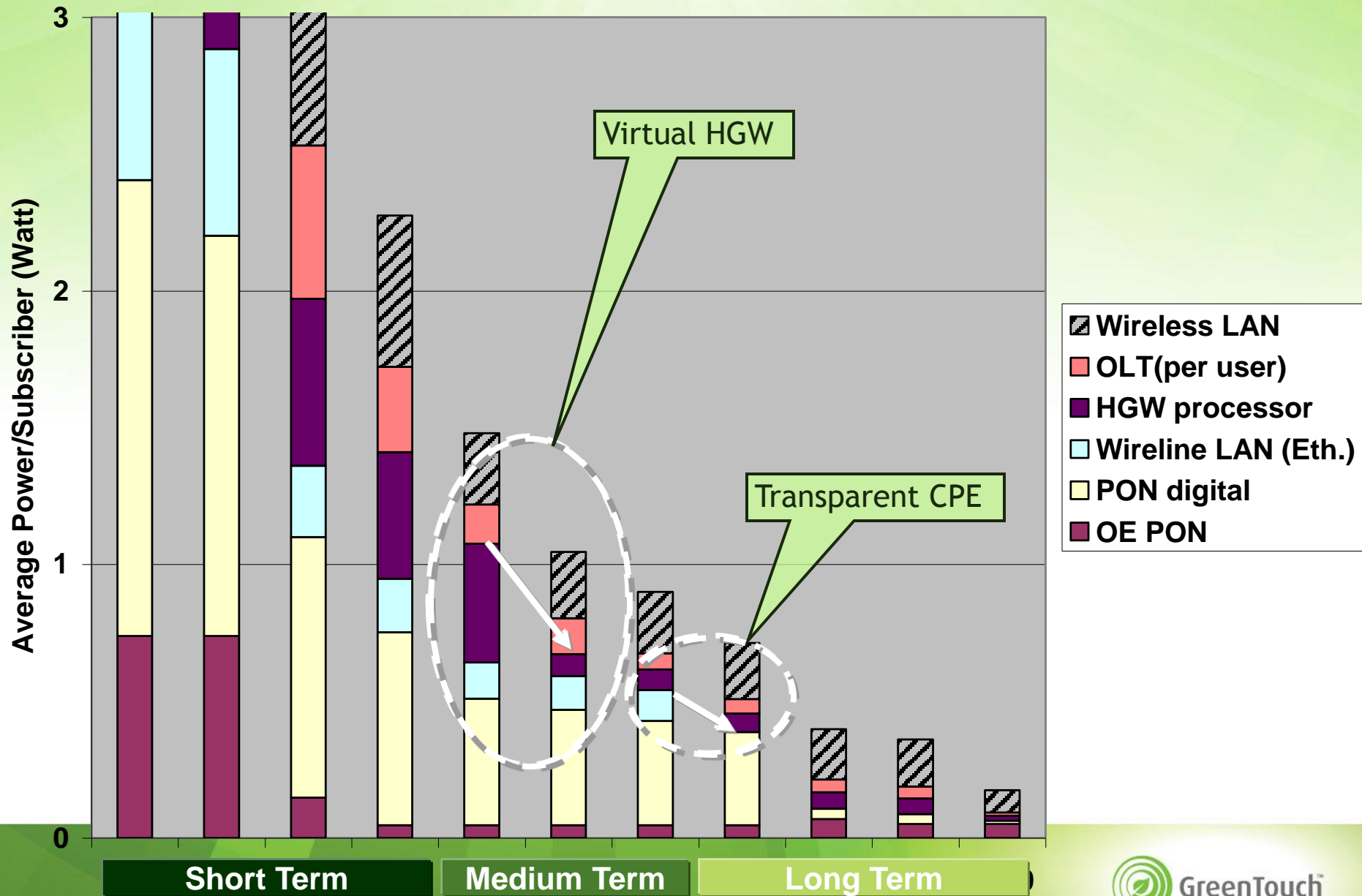

Wireline Access Energy efficiency

