

2012 Ontario Building Code Report - Part 4

WARNING

No representation or warranty is given that your particular application of these products complies with relevant building codes or that the fasteners provided or used are appropriate for your application. Therefore consult with professionals and local building officials before beginning work: (i) to ensure compliance with relevant building codes for your application and for your proposed use of fasteners; (ii) to ensure the integrity of the structural components in connection with which these products are to be used; (iii) to identify appropriate safety gear that is to be used during installation such as a safety harness when working above ground; (iv) to ensure that the work area is free from utilities, services and hazards; and, (v) to clarify any instructions or warnings that may not be clear. Work in a safe manner wearing protective gear such as gloves, eyewear, headwear, footwear and clothing. When using tools always comply with operation manuals and instructions. Metal and glass may have sharp edges and could fragment or splinter during or as a result of handling or cutting. Do not use these products in connection with any substance that is or may be harmful or corrosive to the products. Inspect and maintain these products and the structural components that they are used in connection with on a regular basis using professionals when appropriate. These instructions have been prepared for certain standard residential applications. Obtain professional advice for any non-standard or non-residential application.

RAILBLAZERS® ALUMINUM RAILING SYSTEM
Engineering Review for Compliance with Ontario
Building Codes Part 4

Peak Products Manufacturing Inc.
Richmond, BC

Prepared for:

Peak Products Manufacturing Inc.
203 - 11782 Hammersmith Way
Richmond, BC V7A 5E2

Attention: Mr. Craig Lawson

Prepared by:

Read Jones Christoffersen Ltd.
Suite 300, 1285 West Broadway
Vancouver, BC V6H 3X8

February 4, 2014
RJC# VAN.106169.0001

TABLE OF CONTENTS

1.0	OVERVIEW	1
2.0	INFILL ELEMENTS	2
3.0	RAIL ELEMENTS	3
4.0	CONNECTORS	3
5.0	RESULTS	4
6.0	CONCLUSION	4

APPENDIX A: LIST OF COMPONENTS

APPENDIX B: ASSEMBLY DRAWINGS

1.0 OVERVIEW

The RailBlazers® Aluminum Railing System is intended to act as a guard or barrier to protect the public from a fall. The objectives were to complete a structural review of the structural components based on Limit States Design, in accordance with applicable material standards and Part 4 of the Ontario Building Code 2012.

The following specified loads apply:

- Concentrated lateral load of 1 kN (applied at top of guard)
- Uniformly distributed lateral load of 0.75 kN/m (applied at top of guard)
- Uniformly distributed vertical load of 1.5 kN/m (applied at top of guard)
- Concentrated infill load of 0.5kN (anywhere within the guard)
- Uniform wind load per the limits shown in Appendix B Assembly Drawings.

In this report, the following structural components were reviewed:

A. Infill Elements

1. Wide aluminum pickets 38 mm (1½") wide - Dwg. "RailBlazers® - Railing Assembly with Wide Pickets"
2. Glass panels up to 1.676 m (66") wide - Dwg. "RailBlazers® - Railing Assembly with Glass Panel"

B. Rail Elements

1. Post - Dwg. "Posts"
2. Hand rail - See Report Assembly drawings
3. Base rail - See Report Assembly drawings

C. Connectors

1. Universal connector - Dwg. "Brackets and Connectors" - SKU 10900, 10901
2. Wall mount brackets - Dwg. "Brackets and Connectors" - SKU 10920, 10921
3. Mid/stair/end fascia mount bracket - Dwg. "Fascia Mount Brackets" - SKU 10970, 10971
4. Corner fascia mount bracket - Dwg. "Fascia Mount Brackets" - SKU 10960, 10961

The complete list of system components covered under this evaluation (including non-structural components) is included in Appendix A.

2.0 INFILL ELEMENTS

The primary infill elements included: 38 mm (1½") wide aluminum picket, and 6 mm (¼") thick glass panels (up to 1.676 m (66") wide).

The review was based on information and drawings provided by Peak Products Manufacturing Inc. (Peak) for the elements listed above.

2.1 Aluminum Infill Elements

Our analysis was based on the following information:

- Loads: Prescribed by the Ontario Building Code. See Section 2.0, Overview.
- Resistance: Completed in accordance with CAN/CSA S157-05, Strength in Aluminum Design.
- Section properties: Determined from drawings provided by Peak. Calculations were completed in accordance with CAN/CSA S157-05.
- Load configuration: Span and bearing lengths were provided by Peak.

2.2 Glass Infill Elements

Our analysis was based on the following information:

- Loads (Live and Wind): Prescribed by the Ontario Building Code. See Section 2.0, Overview.
- Resistance: Completed in accordance with CAN/CGSB 12.20-M89, Structural Design of Glass for Buildings.
- Material: Tempered glass in accordance with CAN/CGSB-12.1-M90 per information and drawings provided by Peak.
- Section properties: Determined from drawings provided by Peak.
- Load configuration: Span and bearing lengths were provided by Peak. The glass panels were analyzed based on having pinned (simply-supported) ends at the top and bottom.
- Allowable deflection: The allowable deflection was calculated based on preventing fall-out of the glass from the frame.

3.0 RAIL ELEMENTS

3.1 General Rail Elements

The general rail elements include the hand rail, base rail, and posts. An analysis was completed based on the worst-case configuration for these elements.

- Loads: Prescribed by the Ontario Building Code. See Section 2.0, Overview.
- Resistance: Completed in accordance with CAN/CSA S157-05, Strength in Aluminum Design.
- Section properties: Determined from drawings provided by Peak. Calculations were completed in accordance with CAN/CSA S157-05.
- Fastener resistance: Completed in accordance with CAN/CSA S16-09, Design of Steel Structures.
- Load configuration: Span and dimensions were provided by Peak. Posts were modeled as cantilevers, fixed at the base. The results from our analysis show the maximum span that can be achieved, as calculated from the material and fastener resistances.

4.0 CONNECTORS

4.1 General Connectors

The general connectors included the universal connector, wall mount brackets, mid/stair/end fascia mount bracket, and corner fascia mount bracket. An analysis was completed based on the worst-case configuration for these elements.

- Loads: Prescribed by the Ontario Building Code. See Section 2.0, Overview.
- Resistance: Completed in accordance with CAN/CSA S157-05, Strength in Aluminum Design and CAN/CSA S16-09, Design of Steel Structures.
- Section properties: Determined by drawings provided by Peak. Calculations were completed in accordance with CAN/CSA S157-05.
- Load configuration: Span and dimensions were provided by Peak.
- Connections to the base building are not included as part of this review, including but not limited to the rail and post connections.

5.0 RESULTS

A full set of calculations and results is presented in RJC #VAN.106169.0001 engineering review package, including:

- Dimensioned drawings of each component, including extrusion drawings
- Calculation sheets for the structural capacity of components listed in 2.0 Overview

The above documents contain proprietary information and as such, have not been included in this report.

6.0 CONCLUSION

The RailBlazers® Aluminum Railing System meets the requirements within Part 4 of the Ontario Building Code 2012. Limitations of compliance are defined in the assembly drawings presented in Appendix B.

Sincerely,

Read Jones Christoffersen Ltd.



Carmen Chun, B.A.Sc., EIT, LEED® AP
Design Engineer

Reviewed by:



Leonard Pianalto, M.Sc., P.Eng., LEED® AP, FEC
Associate

CC/hj

Enc. *Appendix A - List of Components*
Appendix B - Assembly of Drawings

LIMITS OF COMMISSION

RJC prepared this report for the use of Peak Products Manufacturing Inc. The material in it reflects RJC's judgement in light of information available to RJC at the time of preparation, including but not limited to material data sheets, independent testing, and physical mock-ups. Any use that a third party makes of this report, or any reliance or decisions to be based on it, is the responsibility of such third parties. RJC accepts no responsibility for damages, if any, suffered by any third party as a result of decisions made or actions based on this report.

This report was prepared for Peak Products Manufacturing Inc. It is not for the use or benefit of, nor may it be relied upon, by any other person or entity, without written permission of Read Jones Christoffersen Ltd.

APPENDIX A

LIST OF COMPONENTS

SKU (White)	SKU (Black)	Description
10000	10001	END POST
10010	10011	MID POST
10020	10021	CORNER POST
10050	10051	STAIR POST
10100	10101	4' HAND AND BASE RAIL
10110	10111	6' HAND AND BASE RAIL
10300	10301	4' WIDE PICKETS AND SPACERS
10310	10311	6' WIDE PICKETS AND SPACERS
10360	10361	6' WIDE STAIR PICKETS AND SPACERS
10380	10381	SINGLE WIDE STAIR PICKET
10390	10391	SINGLE WIDE PICKET
10820	10820	GLASS PANEL 18" X 36 5/16"
10823	10823	GLASS PANEL 21" X 36 5/16"
10830	10830	GLASS PANEL 24" X 36 5/16"
10833	10833	GLASS PANEL 27" X 36 5/16"
10840	10840	GLASS PANEL 30" X 36 5/16"
10843	10843	GLASS PANEL 33" X 36 5/16"
10850	10850	GLASS PANEL 36" X 36 5/16"
10853	10853	GLASS PANEL 39" X 36 5/16"
10860	10860	GLASS PANEL 42" X 36 5/16"
10863	10863	GLASS PANEL 45" X 36 5/16"
10870	10870	GLASS PANEL 48" X 36 5/16"
10873	10873	GLASS PANEL 51" X 36 5/16"
10880	10880	GLASS PANEL 54" X 36 5/16"
10883	10883	GLASS PANEL 57" X 36 5/16"
10888	10888	GLASS PANEL 60" X 36 5/16"
10891	10891	GLASS PANEL 63" X 36 5/16"
10895	10895	GLASS PANEL 66" X 36 5/16"
10900	10901	UNIVERSAL CONNECTOR
10910	10911	BOTTOM RAIL SUPPORT
10920	10921	WALL MOUNT BRACKETS
10940	10940	6' GLASS GASKET
10960	10961	CORNER FASCIA MOUNT BRACKET
10970	10971	MID/END/STAIR FASCIA MOUNT BRACKET

APPENDIX B

ASSEMBLY DRAWINGS

D

C

B

A

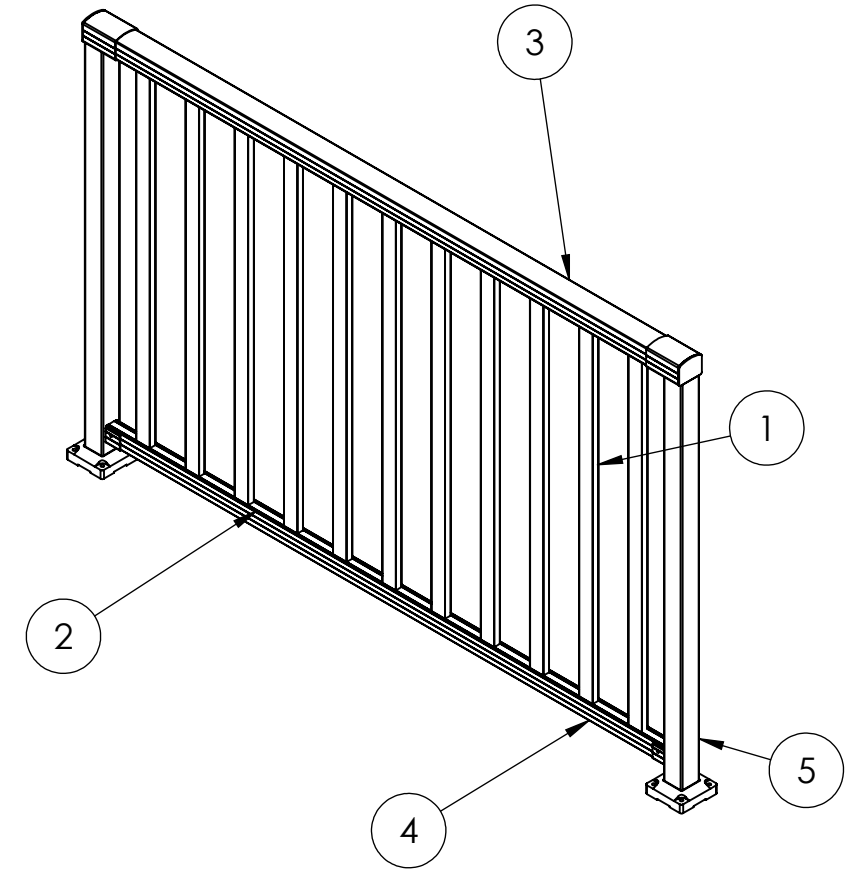
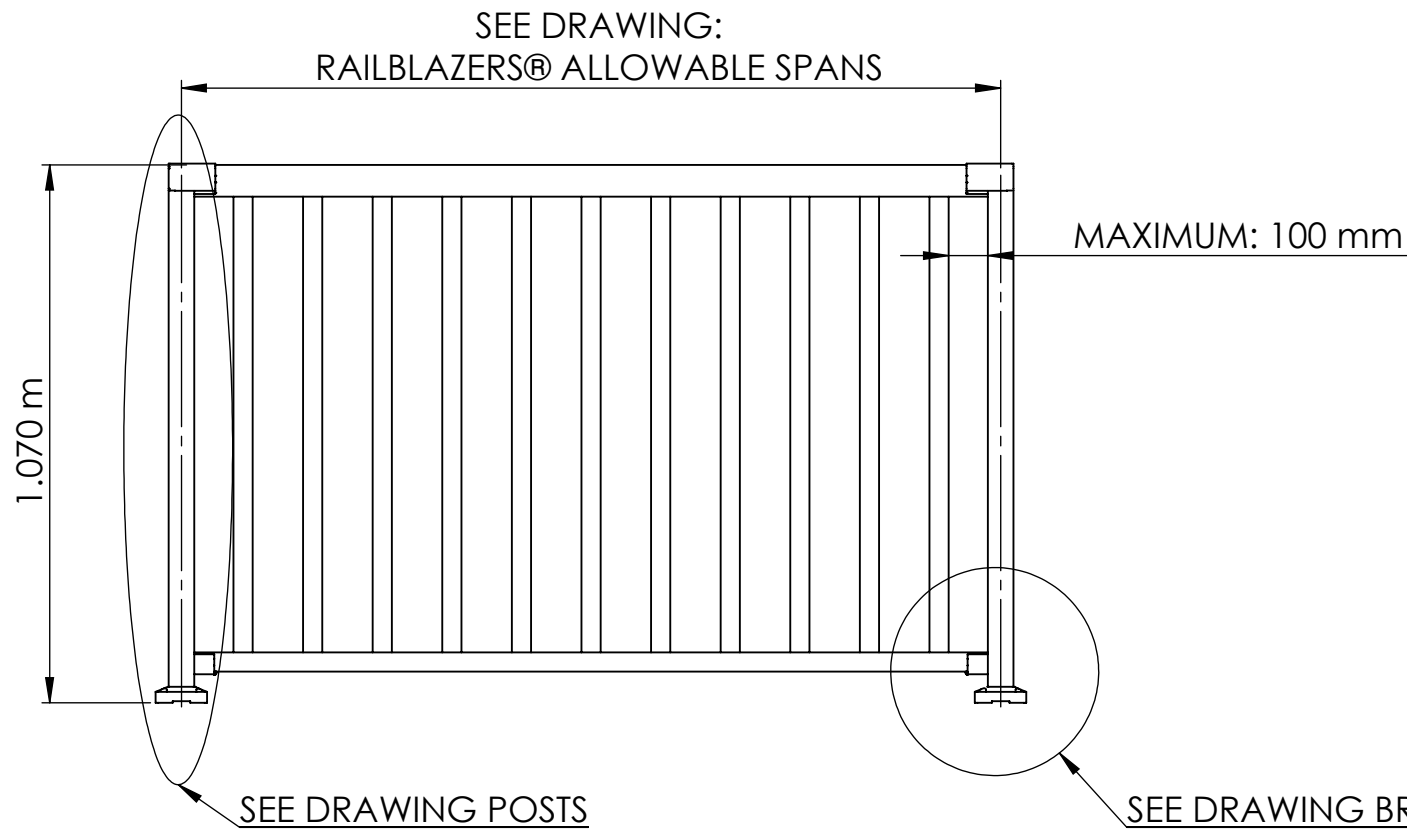
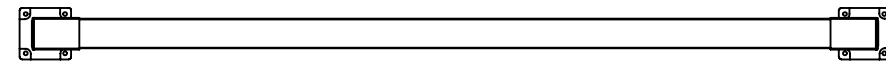

D

C

B

A

DIMENSIONS ARE IN MM UNLESS NOTED			
DO NOT SCALE DRAWING			
MATERIAL Alluminum Alloy			
FINISH Powder Coat			TITLE: RailBlazers® - Railing Assembly with Wide Pickets
PROPRIETARY AND CONFIDENTIAL THE INFORMATION CONTAINED IN THIS DRAWING IS THE SOLE PROPERTY OF THE PEAK GROUP OF COMPANIES. ANY REPRODUCTION IN PART OR AS A WHOLE WITHOUT THE WRITTEN PERMISSION OF THE PEAK GROUP OF COMPANIES IS PROHIBITED.			DWG. NO. Report assembly P4 Assembly Wide Pickets
SCALE: 1:15			
ITEM NO.	DESCRIPTION	SKU	
1	WIDE PICKET	10300, 10301, 10310, 10311, 10360, 10361, 10380, 10381, 10390, 10391	
2	SPACER	10300, 10301, 10310, 10311, 10360, 10361, 10380, 10381, 10390, 10391	
3	HAND RAIL	10100, 10101, 10110, 10111	
4	BASE RAIL	10100, 10101, 10110, 10111	
5	END POST	10000, 10001, 10010, 10011, 10020, 10021, 10050, 10051	

8

7

6

5

4

3

2

1

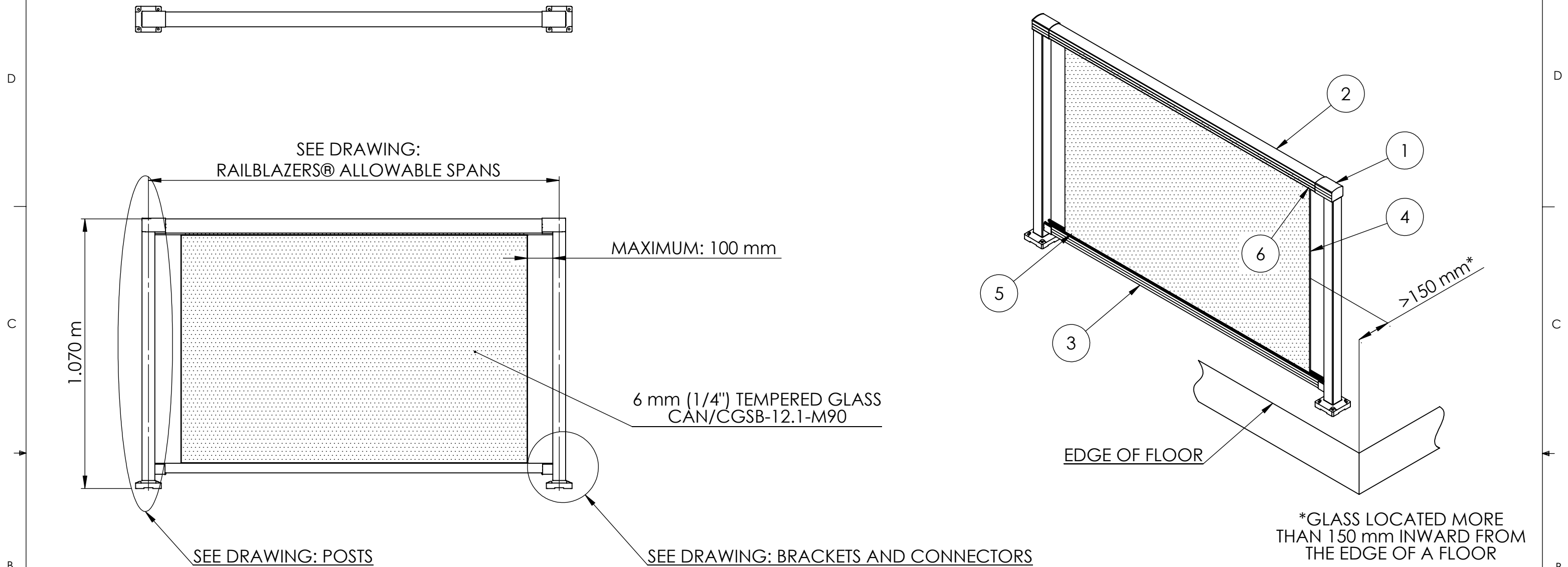

BOM Table

ITEM NO.	DESCRIPTION	SKU
1	END POST	10000, 10001, 10010, 10011, 10020, 10021, 10050, 10051
2	HAND RAIL	10100, 10101, 10110, 10111
3	BASE RAIL	10100, 10101, 10110, 10111
4	Glass Panel	10820, 10823, 10830, 10833, 10840, 10843, 10850, 10853, 10860, 10863, 10870, 10873, 10880, 10883, 10888
5	LOWER GLASS GASKET	10940
6	UPPER GLASS GASKET	10940

DIMENSIONS ARE IN MM UNLESS NOTED

DO NOT SCALE DRAWING

MATERIAL
Aluminum Alloy and
Tempered Glass

FINISH
Powder Coat

PROPRIETARY AND CONFIDENTIAL
 THE INFORMATION CONTAINED IN THIS
 DRAWING IS THE SOLE PROPERTY OF
 THE PEAK GROUP OF COMPANIES. ANY
 REPRODUCTION IN PART OR AS A WHOLE
 WITHOUT THE WRITTEN PERMISSION OF
 THE PEAK GROUP OF COMPANIES IS
 PROHIBITED.



TITLE:
RailBlazers® - Railing
Assembly with Glass
Panel - Ontario

DWG. NO.
Report assembly P4 Assembly Glass Panel ON

SCALE: 1:15

SINGLE RAILING SECTION

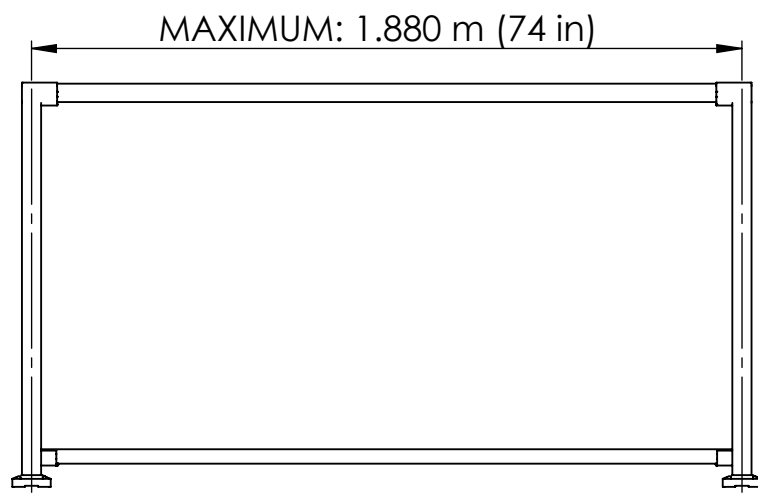

WALL MOUNT SECTION

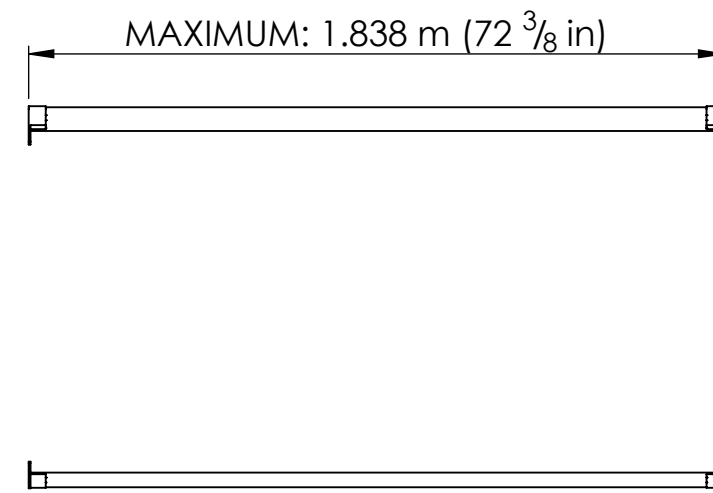

MULTIPLE RAILING SECTIONS

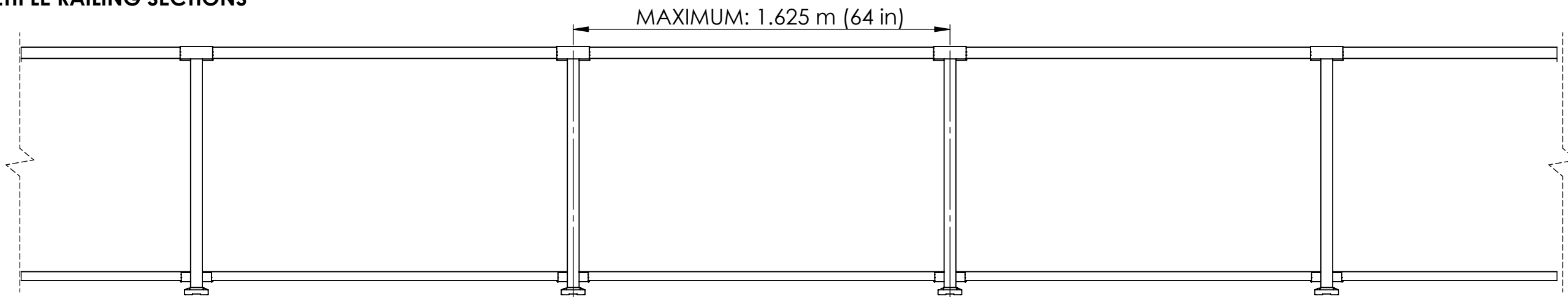

ALLOWABLE SPANS* FOR GLASS PANELS UP TO 1.676 M (66 in.)

Wind Load	Live Load	Maximum Wall Mount Single Span	Maximum Post Spacing	
			Single Section	Multiple Section
≤ 0.2 kPa (low exposure area)	0.75 kN/m	1.838 (72-3/8")	1.880 m (74")	1.625 m (64")
≤ 0.67 kPa (low-rise)	0.75 kN/m	1.838 (72-3/8")	1.880 m (74")	1.524 m (60")
≤ 0.97 kPa (high-rise)	0.75 kN/m	1.838 (72-3/8")	1.880 m (74")	1.422 m (56")
≤ 1.15 kPa (high-exposure area)	1 kN	1.838 (72-3/8")	1.880 m (74")	1.321 m (52")

*Note: The above wind loads provided are guidelines for typical building types for a $q_{50} = 0.48\text{kPa}$ in rough terrain. Actual wind loads must be determined by a professional engineer for the intended location.

DIMENSIONS ARE IN MM UNLESS NOTED				
DO NOT SCALE DRAWING				
MATERIAL Alluminum Alloy		TITLE: RailBlazers® Allowable Spans		
FINISH Powder Coat				
PROPRIETARY AND CONFIDENTIAL THE INFORMATION CONTAINED IN THIS DRAWING IS THE SOLE PROPERTY OF THE PEAK GROUP OF COMPANIES. ANY REPRODUCTION IN PART OR AS A WHOLE WITHOUT THE WRITTEN PERMISSION OF THE PEAK GROUP OF COMPANIES IS PROHIBITED.		SIZE B	DWG. NO. Report assembly P4 Span ON	
		SCALE: 1:20		SHEET 1 OF 1

42 in GLASS PANEL

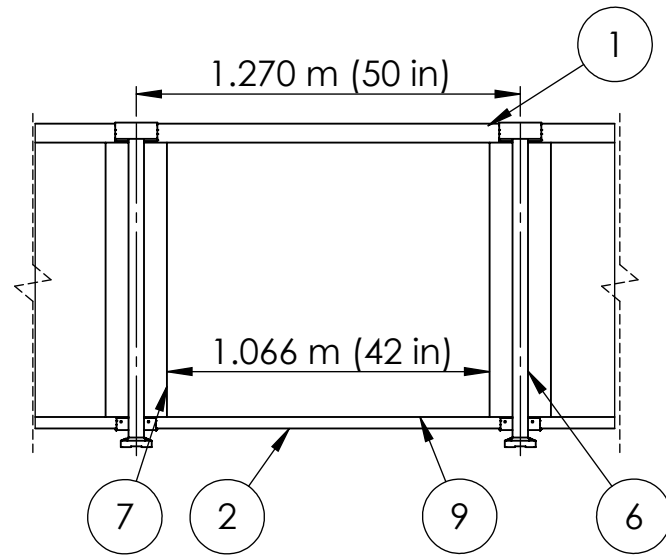

42 in GLASS PANEL AND TWO WIDE PICKETS EACH SECTION

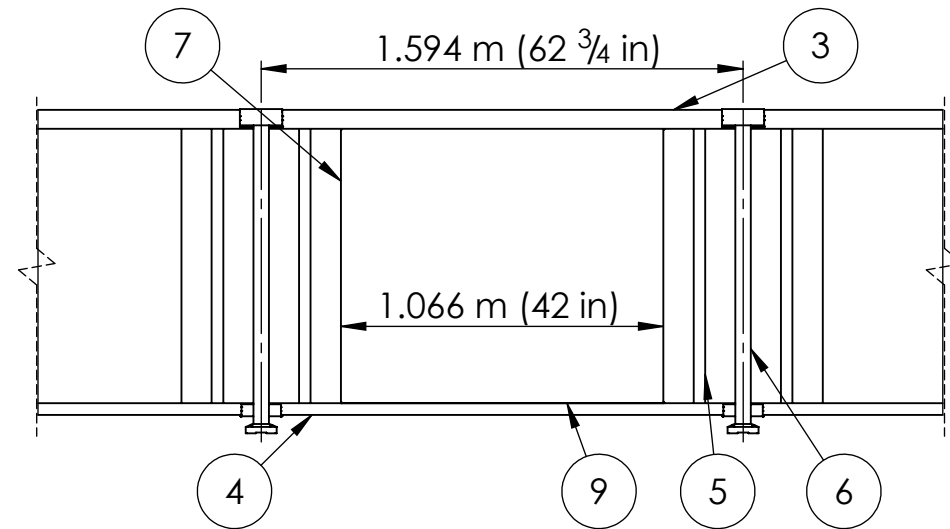

57 in GLASS PANEL

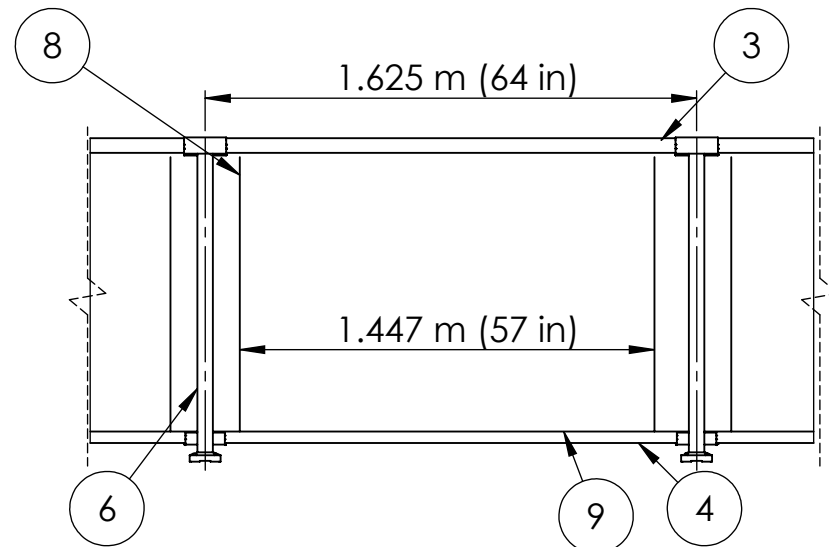

42 in GLASS PANEL AND FOUR WIDE PICKETS EACH SECTION

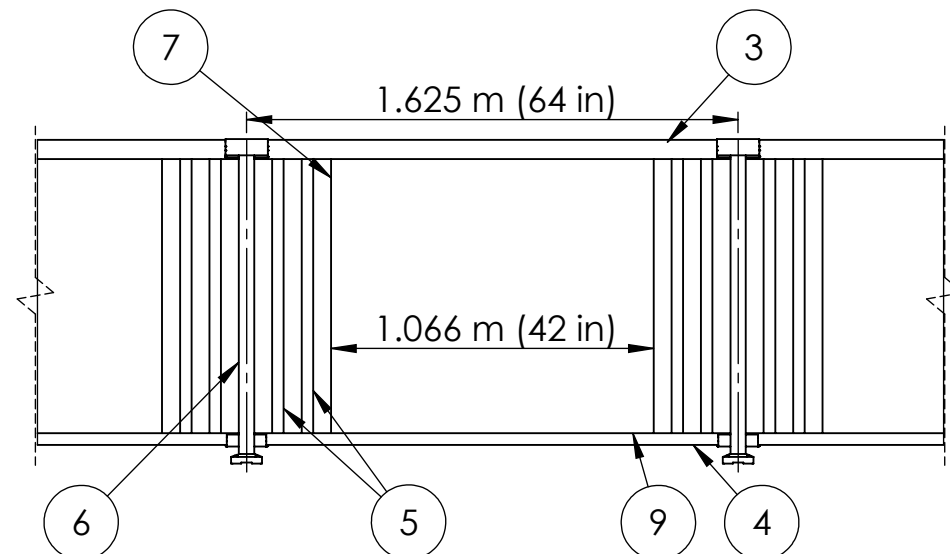

ITEM NO.	DESCRIPTION	SKU
1	HANDRAIL 4 FT	10100, 10101
2	BASE RAIL 4 FT	10100, 10101
3	HANDRAIL 6 FT	10110, 10111
4	BASE RAIL 6 FT	10110, 10111
5	WIDE PICKET	10300, 10301, 10310, 10311, 10360, 10361, 10380, 10381, 10390, 10391
6	POST	10000, 10001, 10010, 10011, 10020, 10021, 10050, 10051
7	GLASS PANEL 42 IN	10860
8	GLASS PANEL 57 IN	10880
9	GLASS GASKET	10940

DIMENSIONS ARE IN MM UNLESS NOTED		 TITLE: RailBlazers® - Recommended Glass Panel Configurations
DO NOT SCALE DRAWING		
MATERIAL Alluminum Alloy		
FINISH Powder Coat		
PROPRIETARY AND CONFIDENTIAL THE INFORMATION CONTAINED IN THIS DRAWING IS THE SOLE PROPERTY OF THE PEAK GROUP OF COMPANIES. ANY REPRODUCTION IN PART OR AS A WHOLE WITHOUT THE WRITTEN PERMISSION OF THE PEAK GROUP OF COMPANIES IS PROHIBITED.		SIZE B
		DWG. NO. Report assembly P4 Glass Examples
SCALE: 1:25		SHEET 1 OF 1

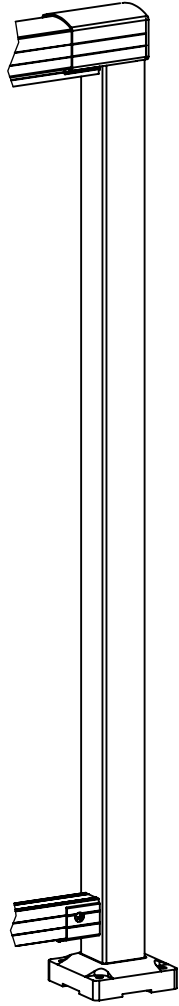

END POST
 SKU: 10000, 10001

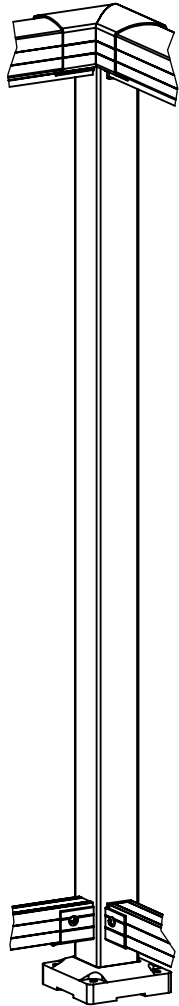

CORNER POST
 SKU: 10010, 10011

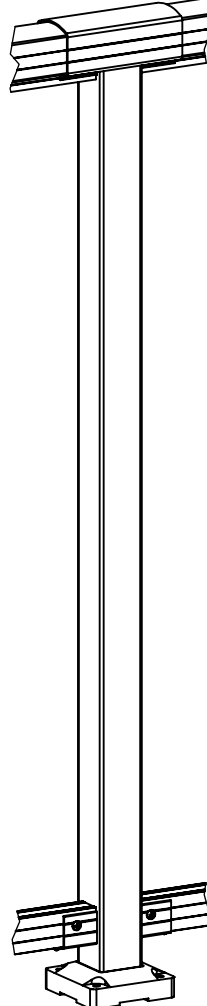

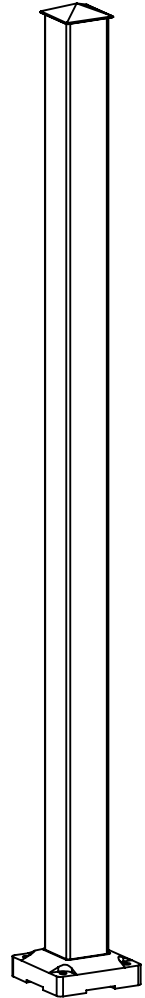

MID POST
 SKU: 10020, 10021

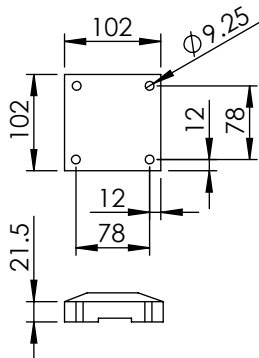

STAIR POST
 SKU: 10050, 10051

MOUNTING
 TEMPLATE:



DIMENSIONS ARE IN MM UNLESS NOTED			
DO NOT SCALE DRAWING			
MATERIAL Aluminum Alloy		TITLE: POSTS	
FINISH Powder Coat			
PROPRIETARY AND CONFIDENTIAL THE INFORMATION CONTAINED IN THIS DRAWING IS THE SOLE PROPERTY OF THE PEAK GROUP OF COMPANIES. ANY REPRODUCTION IN PART OR AS A WHOLE WITHOUT THE WRITTEN PERMISSION OF THE PEAK GROUP OF COMPANIES IS PROHIBITED.		DWG. NO. Report-posts	
		SCALE: 1:8	

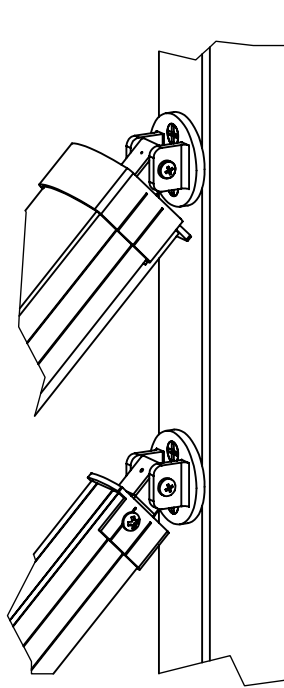

MOUNTING
 TEMPLATE:

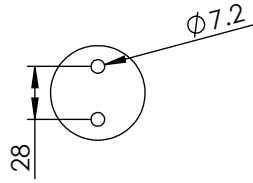

UNIVERSAL CONNECTOR -
 VERTICAL INSTALLATION
 SKU: 10900, 10901

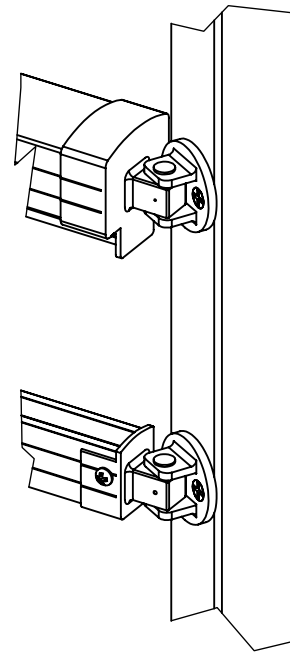

MOUNTING
 TEMPLATE:

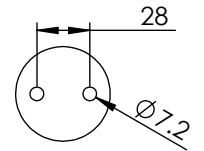

UNIVERSAL CONNECTOR -
 HORIZONTAL INSTALLATION
 SKU: 10900, 10901

MOUNTING
 TEMPLATE:

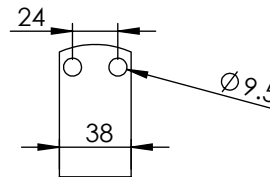
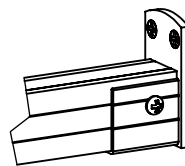
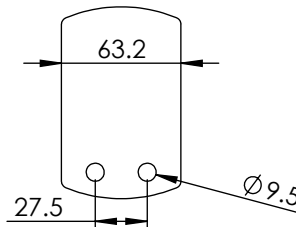
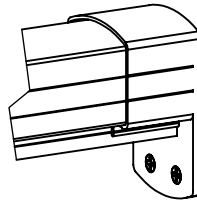

WALL MOUNT BRACKETS
 SKU: 10920, 10921

DIMENSIONS ARE IN MM UNLESS NOTED		
DO NOT SCALE DRAWING		
MATERIAL	Aluminum Alloy	TITLE: BRACKETS AND CONNECTORS
FINISH	Powder Coat	
PROPRIETARY AND CONFIDENTIAL THE INFORMATION CONTAINED IN THIS DRAWING IS THE SOLE PROPERTY OF THE PEAK GROUP OF COMPANIES. ANY REPRODUCTION IN PART OR AS A WHOLE WITHOUT THE WRITTEN PERMISSION OF THE PEAK GROUP OF COMPANIES IS PROHIBITED.		DWG. NO. Report-brackets r2
SCALE: 1:4		

LEFT MOUNTING
 TEMPLATE:

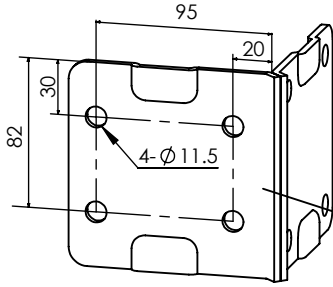

RIGHT MOUNTING
 TEMPLATE:

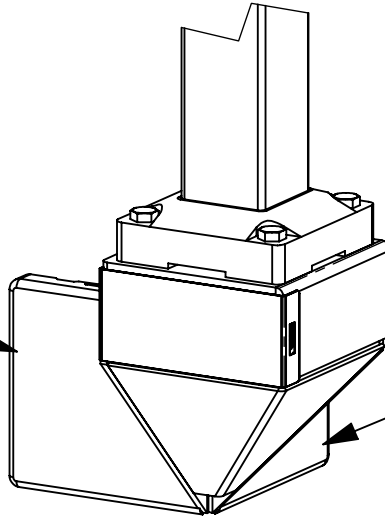
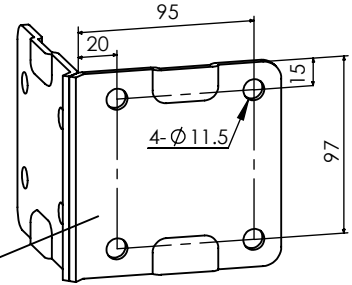

CORNER FASCIA
 MOUNT BRACKET
 SKU: 10960, 10961

MOUNTING
 TEMPLATE:

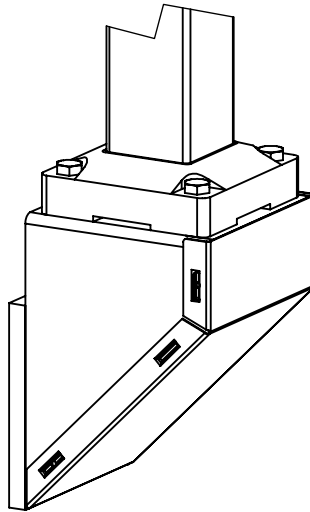
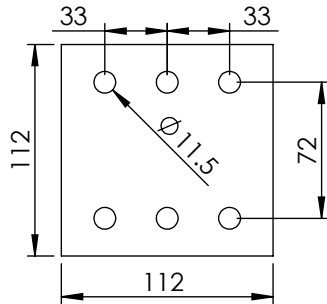

MID/STAIR/END FASCIA
 MOUNT BRACKET
 SKU: 10970, 10971

DIMENSIONS ARE IN MM UNLESS NOTED			
DO NOT SCALE DRAWING			
MATERIAL Plain Carbon Steel		TITLE: FASCIA MOUNT BRACKETS	
FINISH Powder Coat			
PROPRIETARY AND CONFIDENTIAL THE INFORMATION CONTAINED IN THIS DRAWING IS THE SOLE PROPERTY OF THE PEAK GROUP OF COMPANIES. ANY REPRODUCTION IN PART OR AS A WHOLE WITHOUT THE WRITTEN PERMISSION OF THE PEAK GROUP OF COMPANIES IS PROHIBITED.		SIZE	DWG. NO.
		B	Report-brackets r2
		SCALE: 1:4	