

VISIONIAS

www.visionias.in

SCIENCE & TECHNOLOGY - I EMERGING TECHNOLOGY AND CURRENT AFFAIRS 2015

Copyright © by Vision IAS

All rights are reserved. No part of this document may be reproduced, stored in a retrieval system or transmitted in any form or by any means, electronic, mechanical, photocopying, recording or otherwise, without prior permission of Vision IAS.

TABLE OF CONTENTS

Section A: Emerging Technology	7
1. Project Loon	7
1.1. How the Technology works	7
1.2. How Loon moves?	7
1.3. Significance of Project Loon	8
2. Memcomputers	8
3. Fuel Cell Vehicles	8
3.1. What is Fuel Cell?	8
3.2. Advantages of Fuel cell vehicles:	9
3.3. Challenges:	9
4. Recyclable Thermoset Plastics	10
4.1. Difference between Thermoplastics and Thermosetting plastics:	10
4.2. Properties	10
4.3. Recycling of Thermosets	10
5. Genome Editing	10
5.1. What is Genome?	10
5.2. What is Genome Editing?	11
5.3. Methods of Genome Editing	11
5.4. Can genome editing be used therapeutically?	11
6. Digital genome	11
6.1. Uses of Digital Genome	11
7. Internet of DNA-Networks of Genome Data	12
7.1. Genome sequencing?	12
7.2. Why Genome sequencing is important?	12
7.3. What is Internet of DNA?	12
8. Industry Assembled PSLV	13
9. Supercharged Photosynthesis	13
9.1. Breakthrough in the yield process of plant!	13
9.2. Remaining Hurdles	14
10. Augmented Reality (AR)	14
10.1. Difference between Augmented Reality and Virtual Reality	15
10.2. Applications of Augmented Reality	15
11. Virtual Reality	15
11.1. What is virtual reality?	15
11.2. Applications of virtual reality:	16
12. STAP Cells	16
12.1. Recent controversy on STAP Cells	16
12.2. Applications of STAP Cells	16
13. Microgrid	17
13.1. How does Microgrid works?	17
13.2. How does Microgrid connect to the grid?	17
13.3. Why microgrid is necessary?	17
14. Salvage Therapy	17
15. QR Codes	18
15.1. Features of QR code	18
15.2. Applications of QR Code:	18
16. Distributed Manufacturing	19

16.1. How Does It Work? _____	19
16.2. Benefits: _____	19
16.3. Risks: _____	19
17. Hybrid Cars _____	19
17.1. Benefits: _____	19
18. Superbugs _____	20
18.1. How to tackle resistance of Superbugs? _____	20
19. Precise genetic-engineering techniques _____	20
19.1. Why it is important: _____	21
19.2. Application _____	21
20. M5 Synthetic Peptide _____	21
20.1. Significance _____	21
20.2. Challenges and Concerns _____	22
20.3. Significance for India _____	22
21. MRT (Mitochondrial Replacement Therapy) Technique _____	22
21.1. Significance _____	22
21.2. Significance for India _____	23
21.3. Concerns and Challenges _____	23
22. Exascale Computing _____	23
22.1. Why in news? _____	23
22.2. Challenges: _____	24
23. Neuromorphic engineering/technology _____	24
23.1. What is “Neuromorphic technology”? _____	24
23.2. Applications of Neuromorphic technology: _____	24
24. Neuromorphic chips _____	25
24.1. What are Neuromorphic chips? _____	25
24.2. Uses of Neuromorphic Chips _____	25
25. Brain Mapping _____	25
25.1. Benefits: _____	26
26. Quake Proof building using old tyres _____	26
27. Black arsenic-phosphorous _____	26
28. Brain Net _____	26
29. Nano Architecture _____	27
29.1. Potential benefits: _____	27
30. Agricultural Drones _____	27
30.1. Benefits over other technological alternatives: _____	27
30.2. Three types of detailed views and attached benefits: _____	27
30.3. Usages in India: _____	28
31. Light Based Technologies _____	28
31.1. Optogenetics: controlling neurons with light: _____	28
31.2. Li-Fi- LED based Wi-Fi: _____	28
31.3. Simulating sunlight to boost algae power: _____	29
32. Emergent Artificial intelligence (EAI) _____	29
32.1. Understanding EAI _____	29
32.2. Applications of Emergent AI _____	29
33. “Sense and avoid” Drones _____	29
33.1. Applications of “Sense and avoid” Drones _____	30
34. Liquid Biopsy _____	30

34.1. Benefits _____	30
35. Space-Based Solar Power _____	31
35.1. Advantages _____	31
35.2. Disadvantages _____	31
36. High Temperature Superconductors _____	32
37. Carbon Nanotubes (CNT) _____	32
37.1. Structure _____	32
38. Maglev Bullet Train _____	33
38.1. Magnetic levitation technology (maglev) _____	33
39. Regenerative Medicine _____	33
40. Quantum Computer _____	34
41. Solar Photovoltaic Technologies _____	34
41.1. Solar Cells _____	34
41.2. Solar Arrays _____	34
41.3. Concentrated PV (CPV) Systems _____	34
42. Near Field Communication (NCF) _____	35
42.1. Applications _____	35
43. Designer Baby _____	35
44. Biosimilar _____	35
45. Vertical Farming- (Farm Vertically) _____	36
45.1. Advantages of Vertical Farming _____	36
46. Stem Cell Treatments _____	37
47. Robotic Surgery _____	38
48. Personalized Medicine _____	38
49. Claytronics _____	39
50. Chemical Computer _____	39
51. Quantum Dot Display/QLED or QDLED _____	39
51.1. QLEDs advantages _____	40
51.2. Disadvantages _____	40
52. Head Transplant _____	40
53. Hibernation _____	40
54. Tissue Engineering _____	41
55. Cryoprotectant _____	41
56. Memristor _____	42
57. Electronic Nose _____	42
57.1. Recent Advances _____	43
58. Optical Computing _____	43
59. Quantum Dot _____	43
60. Molecular Nanotechnology _____	44
61. Induced Pluripotent Stem Cells (IPSC) _____	45
62. Next Generation Robotics _____	45
62.1. Different layers of Intelligence in Robots: _____	45

62.2. Applications _____	45
62.3. Apprehension: _____	46
63. Metamaterials _____	46
64. Bio-Digester _____	47
64.1. Benefits of using a Biodigester: _____	47
Section B: Current affairs (January to September) _____	48
1. Topic: Science and Technology Developments _____	48
1.1. Nobel Prize in Physics 2015 _____	48
1.1.1. India-based Neutrino Observatory (INO) _____	48
1.2. Nobel Prize in Chemistry _____	50
1.3. Nobel Prize in Medicine _____	51
1.4. India associate member in CERN _____	52
1.5. Gravitational Waves _____	52
1.6. Large Hadron Collider restarts experiments after two-year upgrade _____	52
1.7. Parthenogenesis/ Virgin Birth _____	53
1.8. Powerwall _____	53
2. Topic: Indigenization of Technology _____	54
2.1. iRIDS _____	54
2.2. DigiLocker _____	54
2.3. Steps taken by railway to improve service delivery _____	55
2.4. The Indian Naval Indigenisation Plan 2015-2030 _____	56
2.5. Atal Innovation Mission (AIM) _____	56
2.6. Agni-V _____	57
2.7. AWACS (Airborne Warning and Control Systems) _____	58
2.8. Floating test range for Ballistic missile defence system–BMD Phase 2 _____	58
2.9. Cloud seeding _____	59
2.10. Silage _____	60
2.11. Kalpakkam fast breeder reactor to be commissioned soon _____	60
3. Topic: Space _____	61
3.1. Chandrayaan 2 _____	61
3.2. Aditya-1 _____	62
3.3. Problem of Waste Deposits in Space _____	62
3.4. CASPOL _____	63
3.5. Goldilocks zone _____	63
3.6. Beagle 2 _____	63
3.7. Ceres _____	64
3.8. Mars One _____	64
3.9. Solar Power Station in Space _____	64
3.10. 25 years of the Hubble Space Telescope _____	65
3.11. New Horizons _____	65
3.12. Messenger (Mercury Surface, Space Environment, Geochemistry, and Ranging) Spacecraft _____	66
3.13. India to Test Reusable Launch Vehicle in July: ISRO _____	66
3.14. Sakaar _____	67
3.15. International Space Station (ISS) _____	67
3.16. Philae _____	67
3.17. ISRO successfully launched 5 UK satellites _____	68
3.18. SAARC Satellite Expected to be Launched in December 2016 _____	68
3.19. GPS-Aided Geo Augmented Navigation (GAGAN) system _____	68
3.20. ISRO's titanium sponge plant in Kerala fully commissioned _____	70
3.21. GSLV D6 successfully Launched _____	70
3.22. GSAT-6 (Geosynchronous Satellite) _____	71
3.23. Multi-Application Solar Telescope (MAST) Operationalized at Udaipur Solar OBSERVATORY (USO) _____	71
3.24. Semi-cryogenic launch vehicle _____	72
3.25. ASTROSAT _____	72
3.26. LAPAN A2/Orari _____	73

3.27. NASA's SERVIR-Mekong project _____	74
3.28. Mission on Mars (Mangalyaan) – A technology demonstrator mission _____	74
4. Topic: Biotechnology _____	75
4.1. Genetically editing human embryos _____	75
4.2. CSIR succeeds in Whole Genome Sequencing of Holy basil (Tulsi) _____	75
5. Topic: IT and Computers _____	76
5.1. Internet.org _____	76
5.2. MOOC _____	77
6. Topic: Health _____	78
6.1. Three-Parent babies _____	78
6.2. Personalised TB treatment _____	79
7. Topic: Environment _____	80
7.1. Carbon dioxide Fertilization _____	80
7.2. Plant Protection Code (PPC) _____	80
7.3. The menace of plastic waste _____	80
7.4. National Air Quality Index (AQI) _____	82
7.5. Incinerator technology for producing Refuse Derived Fuel (RDF) _____	83
7.6. Interlinking of rivers _____	84
7.7. Heat wave _____	86
7.8. Konkan Railways environment friendly initiative _____	86
7.9. Mercury pollution _____	87
7.10. Kasturirangan report on Western Ghats _____	87
7.11. National Renewable Energy Bill, 2015 _____	88

SECTION A: EMERGING TECHNOLOGY

1. PROJECT LOON

- Google has envisaged the Project Loon. It is a **network of balloons** travelling on the edge of space, designed to connect people in rural and remote areas. It will help fill coverage gaps and also bring people back online after disasters.
- The balloon is also considerably used to gather weather information such as atmospheric pressure, temperature, humidity and wind speed.

1.1. HOW THE TECHNOLOGY WORKS

- **Project Loon:** balloons float in the stratosphere, twice as high as airplanes and the weather.
- They are carried around the Earth by winds and they can be steered by rising or descending to an altitude with winds moving in the desired direction.
- People connect to the balloon network using a special internet antenna attached to their building.
- The signal bounces from balloon to balloon, then to the global internet back on the Earth.

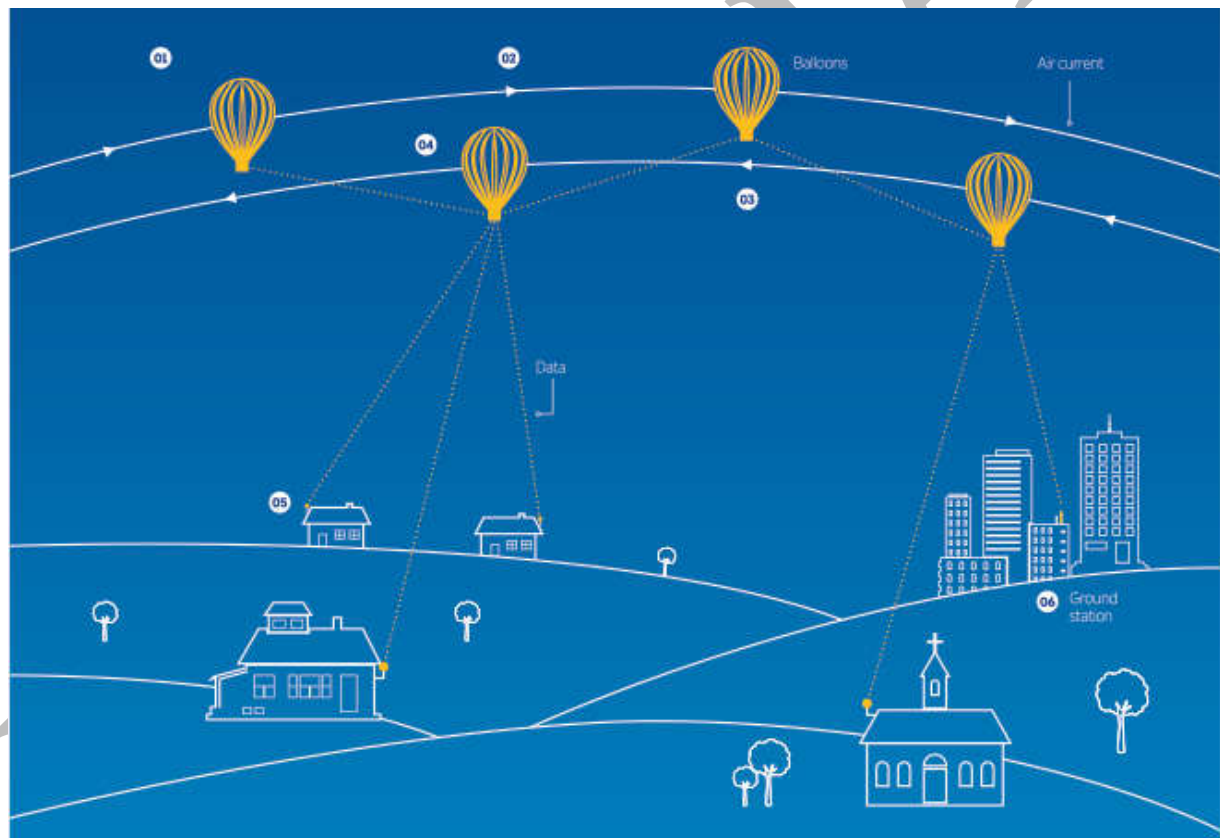

Fig. Project Loon

1.2. HOW LOON MOVES?

- Winds in the stratosphere are generally steady and slow-moving at between 5-20 mph, and each layer of wind varies in direction.
- Project Loon uses software algorithms to determine where its balloons need to go, then moves each one into a layer of wind blowing in the right direction.
- By moving with the wind, the balloons can be arranged to form one large communications network.

1.3. SIGNIFICANCE OF PROJECT LOON

Advantages	Disadvantages
<ul style="list-style-type: none">• Lower cost	<ul style="list-style-type: none">• Chances of Hardware Failure
<ul style="list-style-type: none">• Availability of information	<ul style="list-style-type: none">• Breach of internet privacy
<ul style="list-style-type: none">• Education	<ul style="list-style-type: none">• Not a replacement of satellite communication
<ul style="list-style-type: none">• Health and Medicine	<ul style="list-style-type: none">• International Politics
<ul style="list-style-type: none">• Connectivity	

2. MEMCOMPUTERS

- A new type of computer that works by mimicking the human brain.
- In conventional computers, Processors, which executes computations, and Memory, which stores data, are separate components.
- Due to this, transfer of data between processor and memory consumes time and energy, putting limitations on its computation power.
- **Memcomputers, in contrast, are made up of “memprocessors”, that both process and store data at the same place.**
- This setup mimics the neurons that make up the human brain, with each neuron serving as both the processor and the memory.
- It is expected to overcome many limitations of conventional computers in complex computations.
- Unlike Quantum computers which operate at extremely low temperatures, Memcomputers can operate at room temperature also.
- This new brain-inspired computer device could help neuroscientists better understand the workings of human brains.
- Though this idea was mooted as early as 1970's, this is the first prototype machine of this architecture.

3. FUEL CELL VEHICLES

3.1. WHAT IS FUEL CELL?

- A fuel cell is a device that **converts the chemical energy from a fuel into electricity** through a chemical reaction.
- Every Fuel cell has **two electrode**- Positive and Negative, an **electrolyte**, which carries electrically charged particles from one electrode to other, and **catalysts**, which speeds the reaction at the electrodes.
- It generates **Direct Current (DC)** electricity. Hydrogen is the **basic fuel**, but fuel cell also requires **oxygen**.
- Fuel cell generates electricity with **very little pollution** as much of the hydrogen and oxygen used in generating electricity, ultimately combine to form a **harmless by-product** i.e. Water.
- Because of **modular nature**, fuel cells are **ideally suited for de-centralized power generation** and for automotive application.
- The fuel cell technology offers **high conversion efficiency, modularity, compactness** and **noise-free operations**.

3.2. ADVANTAGES OF FUEL CELL VEHICLES:

- Energy Diversification
- **Reduced greenhouse gas emissions**, Reduced oil consumption, Expanded use of renewable power (through use of hydrogen for energy storage and transmission)
- Highly efficient energy conversion, fuel flexibility.
- Reduced air pollution
- Quiet operation, low maintenance needs, and high reliability
- Fuel cells can provide power from a variety of other fuels, including natural gas and renewable fuels such as methanol or biogas.

How fuel cell cars work

A fuel cell is a clean and efficient power plant that makes electricity through a chemical reaction between hydrogen and oxygen.

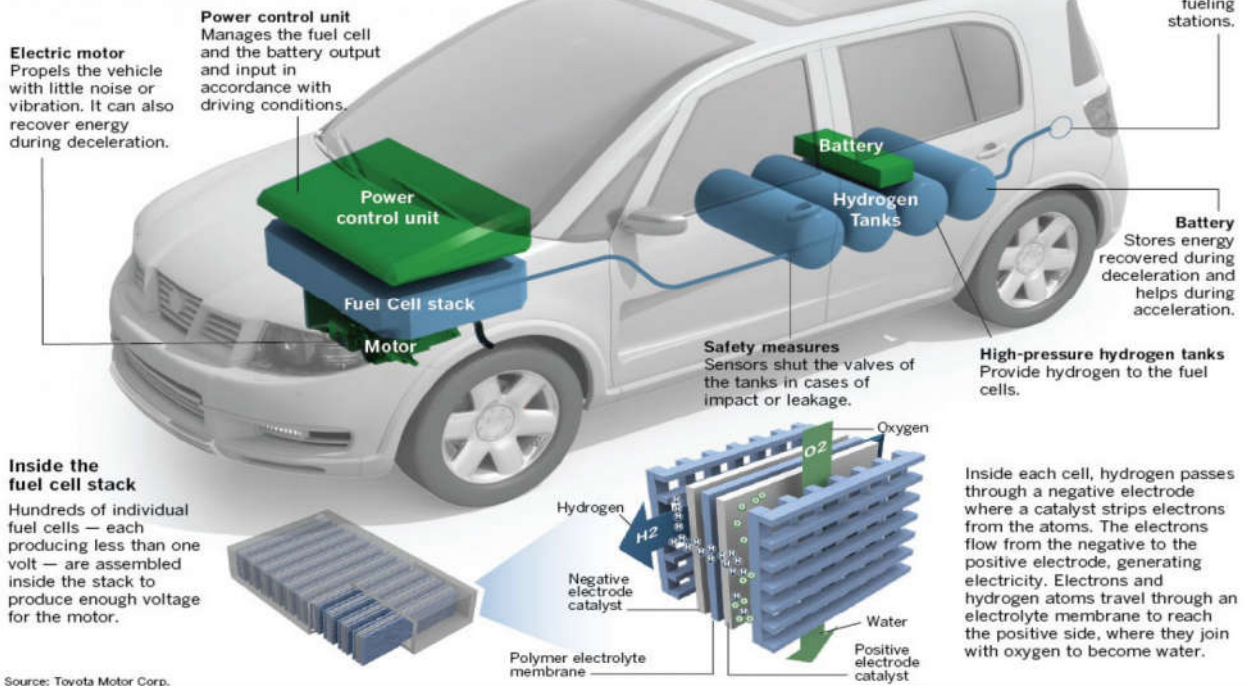

3.3. CHALLENGES:

- **Fuel Cell Cost and Durability:** Vehicle drivability, operation, and survivability in extreme climates and emissions have not been proven yet.
- **Hydrogen Storage:** Current technology does not provide reasonable cost and volume for transportation or stationary applications. An understanding of composite tank operating cycle life and failure due to accident or neglect is lacking.
- **Hydrogen Production and Delivery:** The high cost of hydrogen production, low availability of the hydrogen production systems, and the challenge of providing safe production and delivery systems are penetration barriers.
- Public Acceptance and awareness is very low.

4. RECYCLABLE THERMOSET PLASTICS

- Plastics are divided into 'thermoplastics' and 'thermoset' plastics.
- Thermoplastics can be heated and shaped many times, and are ubiquitous in the modern world, because they can be melted down and reshaped. They are generally recyclable.
- **Thermoset plastics however can only be heated and shaped once**, after which molecular changes mean that they are "cured", retaining their shape and strength.

4.1. DIFFERENCE BETWEEN THERMOPLASTICS AND THERMOSETTING PLASTICS:

Thermoplastics	Thermosetting plastics
It can be heated and shaped over and over again	It can only be heated and shaped once
Low Melting Point and Low Tensile strength	High Melting point and High Tensile Strength
Example- PVC and Polythene	Example -Bakelite and Melamine

4.2. PROPERTIES

- Thermosetting plastics **retain their strength and shape even when heated**. This makes thermosetting plastics well-suited to the **production of permanent components and large, solid shapes**.
- Thermoset plastics are a vital part of our modern world, and are used in everything from mobile phones and circuit boards to the aerospace industry.
- **However, it is very difficult to recycle thermoset plastics.**

4.3. RECYCLING OF THERMOSETS

- Recently a new classes of recyclable thermosetting polymers are discovered called-poly hexahydrotriazines, or PHTs.
- It is one of the **strongest thermosets**.
- These can be dissolved in strong acid, breaking apart the polymer chains into component monomers that can then be reassembled into new products.
- Like traditional unrecyclable thermosets, these new structures are rigid, resistant to heat and tough, with the same potential applications as their unrecyclable forerunners.
- Although no recycling is 100% efficient, this innovation – if widely deployed – should speed up the move towards a circular economy with a big reduction in landfill waste from plastics.

Past question from UPSC (2011): Comment on Super Absorbent Polymers. (50 words)

5. GENOME EDITING

5.1. WHAT IS GENOME?

- The genome of an organism is the whole of its hereditary information encoded in its DNA.
- Within DNA there is a unique chemical code that guides our growth, development and health.
- This code is determined by the order of the **four nucleotide bases (DNA bases)** that make up DNA, Adenine, Cytosine, Guanine and Thymine, **A, C, G and T for short**.
- DNA has a twisted structure in the shape of a double helix. **Single strands of DNA are coiled up into structures called chromosomes.**
- Our chromosomes are located in the nucleus within each cell. Within our chromosomes, sections of DNA are "read" together to form genes.

- If genome is sequenced, it looks like:

AGTCCGGGAATACAGGCTCGGT

5.2. WHAT IS GENOME EDITING?

- **Genome editing** is an approach in which the **genome sequence is directly changed by adding, replacing, or removing DNA bases.**
- However, the genome is relatively resistant to change.
- If DNA could be easily altered, many essential cell functions would be disrupted in undesirable ways. To deter any changes from being inadvertently made to DNA, cells have inherent mechanisms to proofread and repair their genetic code.
- Remarkably, **researchers have been able to take advantage of the cell's DNA repair mechanisms to achieve genome editing.**
- To accomplish this, scientists can use **artificially engineered enzymes called nucleases** to crack open DNA strands.
- In effect, these **nucleases act as molecular scissors** that form a break in the DNA double-stranded helix. Once a break is introduced in the DNA, the cell will detect a problem in its genetic code and quickly activate its repair machinery.

5.3. METHODS OF GENOME EDITING

- There are two major methods by which a cell can repair a break in its DNA:
 - **First**, the cell can employ various enzymes to directly join the two ends of the DNA break back together. However, this process is very error-prone and often results in mutations.
 - **Second**, a DNA sequence can be designed to be inserted along with a nuclease, such that when a cut is made in the DNA, the cell's own repair mechanisms can use the DNA sequence supplied to replace an existing DNA sequence as it repairs the break. This method allows scientists to directly change genetic information in cells by introducing a correct version of a DNA sequence **to replace an unwanted mutation.**

5.4. CAN GENOME EDITING BE USED THERAPEUTICALLY?

- Genome editing is already being used by scientists as one of their many tools to develop cell and animal models for studying different diseases.
- **Zinc finger nucleases (ZFNs), a type of nucleases** has been tested as a therapeutic approach in many genetic diseases. For example, in treating Hemophilia, Huntingtons Disease etc.
- Preliminary research suggests that genome editing may be a promising therapeutic approach, but more work is needed prior to clinical testing in humans.

6. DIGITAL GENOME

- While the first sequencing of the 3.2 billion base pairs of DNA that make up the human genome took many years and cost tens of millions of dollars, today our individual unique genetic make-up i.e. Genome can be sequenced and digitized in minutes and at the cost of only a few hundred dollars.
- The results can be delivered to our laptop on a USB stick and easily shared via the internet. This **digitally shared data is Digital Genome.**

6.1. USES OF DIGITAL GENOME

- Many of our most intractable health challenges, from heart disease to cancer, have a genetic component. Cancer is best described as a disease of the genome.
- By analyzing patient's digital genome data doctors can do the following,

- Analyzing carrier status for various genetic diseases such as color blindness, sickle cell anemia, etc.
- Identifying the likelihood of acquiring various common diseases such as diabetes, coronary heart diseases, etc.
- Understanding genetic factors responsible for diseases such as asthma, pulmonary fibrosis, etc.
- Discovery of familial risks for diseases such as breast cancer, colorectal cancer, etc.
- Decreasing adverse reactions to drug molecules.
- Ancestry comparison and Genetic counseling to avoid or minimize auto recessive disorders
- It is helpful in **precision medicine**, by enabling the development of highly targeted therapies that offer the potential for improved treatment outcomes, especially for patients battling cancer.

7. INTERNET OF DNA-NETWORKS OF GENOME DATA

- DNA is the foundation of every living organism on earth.
- Sometimes sequences at nuclear bases **C** (Cytosine), **T** (Thymine), **G** (Guanine), **A** (Adenine) which make-up DNA strands, don't order themselves properly and irregularity occurs.
- Most of the times the irregularity will be corrected by natural body mechanism and any further damage stops in its tracks.
- But in some instances the anomaly does not stop, e.g. in Cancer, Mendelian disorders, Alzheimer disease etc.
- About 1 of 100000000 times, mistake occurs in replicating the cells which can lead to a **mutation**.

7.1. GENOME SEQUENCING?

It is a laboratory process that determines the complete DNA sequence of an organism's genome at a single time.

7.2. WHY GENOME SEQUENCING IS IMPORTANT?

- Genomic information has been instrumental in identifying inherited disorders, characterizing the mutations that drive cancer progression, and tracking disease outbreaks.
- The genome sequence will represent a valuable shortcut, helping scientists find genes much more easily and quickly.
- A genome sequence does contain some clues about where genes are, which will help scientists/doctors to locate mutated genes and ultimately solution to different diseases.



7.3. WHAT IS INTERNET OF DNA?

- In 2013 in New York, geneticists gathered to discuss genome privacy and found that genome sequencing data is largely detached from the Internet which is greatest tool for sharing information.
- Therefore, **The Global Alliance for Genomics and Health (GA4GH)** (non-profit org. established by group of geneticists and programmers) decided to form a **DNA search engine** over the internet that will simplify, process and compare genomes and locate defects and will eventually link millions of genomes together.
- DNA search engine has 2 parts- **Beacon project** and **Match Maker Exchange**.
 - **Beacon project**
 - Instead of transferring information of sequenced genome data stored in hard drives and delivered by trucks and planes, all of it is stored in individual databases that are accessed simultaneously by the DNA search engine.
 - Main goal of the Beacon project is to allow the sharing the genomes with connected databases and access to doctors/researchers who require it.

➤ Match Maker Exchange

- In many cases locating one identical case of similar genome can allow for the identification of the problem of mutation by making use of genomic databases and analysis tool.
- The **Exchange** do the analysis and matches independent genomes.
- Its dual purposes are searching genomic information through Beacon as well as connect researchers for shared interests and/or similar cases.

Together **Beacon** and **Match Maker Exchange** are foundations of Internet of DNA.

8. INDUSTRY ASSEMBLED PSLV

- ISRO is envisaging a more active role for domestic industry in India's space program.
- It is expecting industry-built, assembled and launched PSLV- one of its two launch vehicles,
- The time frame for this industry built PSLV envisaged is about three to four years down the line.
- In the launch of PSLV-C30 mission (which put Astrosat and six foreign satellites in their orbits), there was participation of about 150 companies.
- ISRO is keen to focus on unique science projects, develop remote sensing satellites and do more research and development instead of engaging in the repetitive exercise of building communication satellites and launch vehicles.
- Besides it will also give a boost to manufacturing sector in India.

Past question from IFoS (2011): Comment on SpaceX dragon. (30 words)

9. SUPERCHARGED PHOTOSYNTHESIS

9.1. BREAKTHROUGH IN THE YIELD PROCESS OF PLANT!

- The **supercharged photosynthesis** process, called **C4 photosynthesis**, boosts plants' growth by capturing CO₂ and concentrating it in specialized cells in the leaves.
- That allows the photosynthetic process to operate much more efficiently. That's why **corn and sugarcane** grows so productively (as they possess genes for **C4 photosynthesis**); if C4 rice comes about, it will yield more than conventional rice within a few weeks of planting.

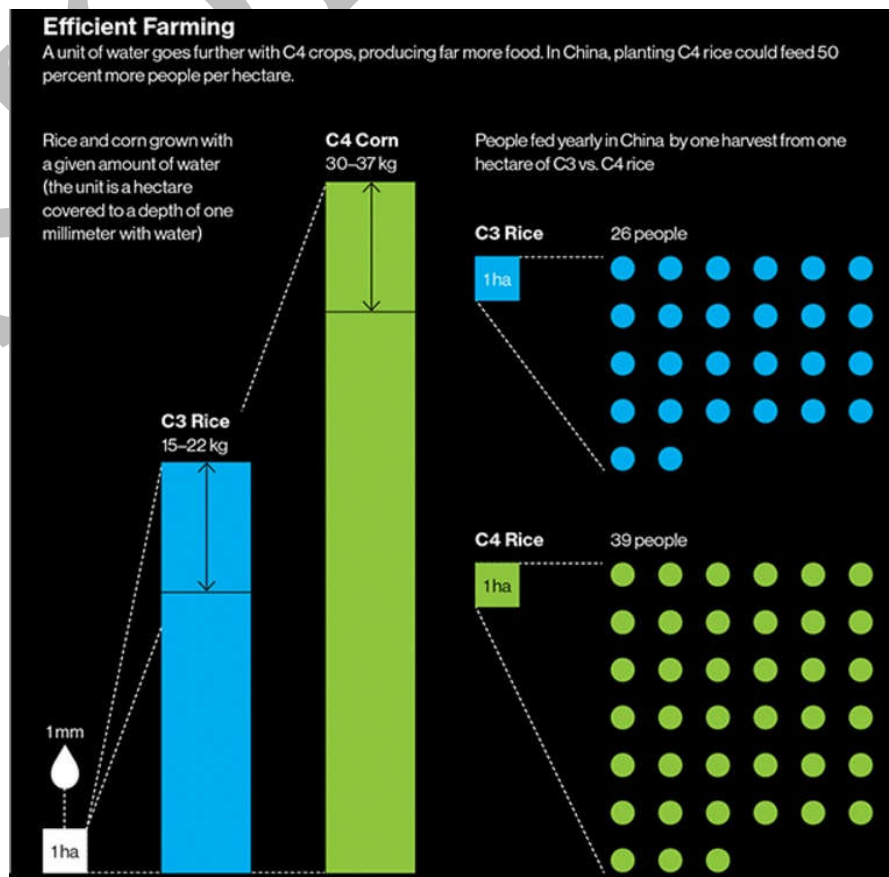

- Researchers calculate that engineering C4 photosynthesis into rice and wheat could increase yields per hectare by roughly 50 percent; alternatively, it would be possible to use far less water and fertilizer to produce the same amount of food.
- A team of scientists from UK have completed two of three necessary steps to turbo-charge photosynthesis in crops like wheat and rice.
- The scientists used genes from a bacteria called cyanobacteria and transplanted them into rice crops. With the genes, plants are able to produce a more efficient enzyme that converts CO₂ into sugars and other carbohydrates.
- The process could help boost crop yields by 36 to 60 percent for variety of plants.

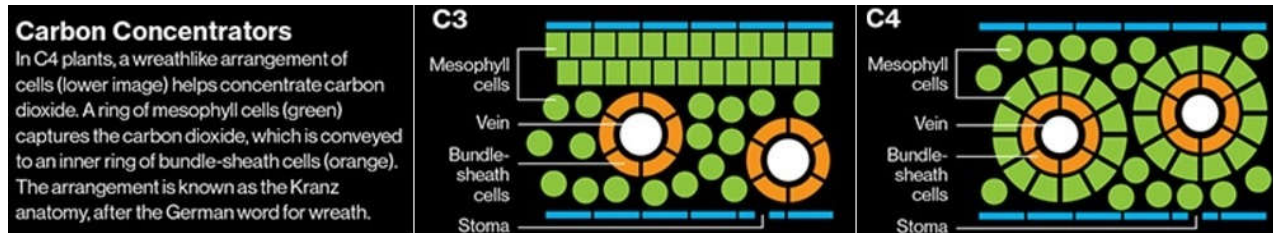

9.2. REMAINING HURDLES

- Despite the genetic changes, the altered rice plants still rely primarily on their usual form of photosynthesis.
- To get them to switch over completely, researchers need to engineer the plants to produce specialized cells in a precise arrangement: **one set of cells to capture the carbon dioxide, surrounding another set of cells that concentrate it.** That's the distinctive wreath anatomy found in the leaves of C4 plants.
- However, scientists still don't know all the genes involved in producing these cells and suspect that they could number in the dozens.
- Using **conventional breeding** to manipulate more than one or two genes is a difficult but with **new genome editing methods** that allow scientists to precisely modify parts of plant genomes could help solve the problem.
- Once scientists solve the C4 puzzle in a plant such as rice, they hope, the method can be extended to dramatically increase production of many other crops, including wheat, potatoes, tomatoes, apples, and soybeans.

10. AUGMENTED REALITY (AR)

- The basic idea of augmented reality is to superimpose graphics, audio and other sensory enhancements over a real-world environment in real time.
- So it's like adding a layer of digital information on top of the physical world around us.
- The interesting example is projecting a calculator on a palm where one can perform normal calculations.
- Many a times Augmented reality is confused with Virtual Reality. However, there are some differences between the two as follows.



Diagram: Illustration of Augmented Reality

10.1. DIFFERENCE BETWEEN AUGMENTED REALITY AND VIRTUAL REALITY

Augmented Reality	Virtual Reality
Augmented reality is the blending of virtual reality and real life , as developers can create images within applications that blend in with contents in the real world.	Virtual reality is all about the creation of a virtual world that users can interact with. This virtual world should be designed in such a way that users would find it difficult to tell the difference from what is real and what is not.
In AR, users continue to be in touch with the real world while interacting with virtual objects around them.	In VR, the user is isolated from the real world while immersed in a world that is completely fabricated.
With AR, users are able to interact with virtual contents in the real world, and are able to distinguish between the two.	VR is usually achieved by the wearing of a VR helmet or goggles similar to the Oculus Rift.

10.2. APPLICATIONS OF AUGMENTED REALITY

- **Navigation:** Enhanced GPS systems are using augmented reality to make it easier to get from point A to point B.
- **Military:** A transparent display is positioned directly in the fighter pilots view, it shows information about altitude, speed etc.
- **Medical:** Medical students use the technology to practice surgery in a controlled environment.
- **Gaming:** With recent advances in computing power and technology, gaming applications in augmented reality are on the upswing.
- AR is also useful in knowing the identity of the people using various facial recognition devices which compares the identity of a person in data bases of social networking sites. However, this application has lot of legal and ethical issues regarding right to privacy, anonymity concerns etc.

11. VIRTUAL REALITY

11.1. WHAT IS VIRTUAL REALITY?

- **Virtual reality (VR)** is an artificial environment that is created with software and presented to the user in such a way that the user suspends belief and accepts it as a real environment.
- On a computer, virtual reality is primarily experienced through two of the five senses: sight and sound.
- Virtual reality can artificially create sensory experiences, which can include sight, hearing, touch, and smell.
- The simplest form of VR is a **3-D image** that can be explored interactively at a personal computer, usually by manipulating keys or the mouse so that the content of the image moves in some direction or zooms in or out.
- More sophisticated efforts involve such approaches as **wrap-around display screens, actual rooms augmented with wearable computers, and haptics devices** (Haptics--the science of applying touch (tactile) sensation and control to interaction with computer applications) that let you feel the display images.
- Virtual reality can be divided into:
 - The simulation of a real environment for training and education.
 - The development of an imagined environment for a game or interactive story.
- The Virtual Reality Modelling Language (VRML) allows the creator to specify images and the rules for their display and interaction using textual language statements.

- Furthermore, virtual reality covers remote communication environments which provide virtual presence of users with the concepts of tele-presence and tele-existence or a virtual artefact (VA) either through the use of standard input devices such as a keyboard and mouse, or through multimodal devices such as a wired glove or omnidirectional treadmills.

11.2. APPLICATIONS OF VIRTUAL REALITY:

- **Education and training-** Using VR, for students doing study can be more interactive in the classroom. It will help in understanding concepts, for recreational activities etc.
- **Training-** The usage of VR in a training perspective is to allow professionals to conduct training in a virtual environment where they can improve upon their skills without the consequence of failing the operation. VR plays an important role in combat training for the military.
- **Video games-** The use of graphics, sound and input technology in video games can be incorporated into VR.
- **Heritage and archaeology-** Virtual reality enables heritage sites to be recreated extremely accurately, so that the recreations can be published in various media. The original sites are often inaccessible to the public, or may even no longer exist. This technology can be used to develop virtual replicas of caves, natural environment, old towns, monuments, sculptures and archaeological elements.
- **Urban design-** VR can be used for urban regeneration and planning and transport projects.
- **Therapy-** The primary use of VR in a therapeutic role is its application to various forms of exposure therapy, including phobia treatments patients.

12. STAP CELLS

- **Stimulus-triggered acquisition of pluripotency** (also known as STAP) is an alleged process of creating **pluripotent stem cells** by subjecting ordinary cells to specific types of stress, such as the application of a bacterial toxin, submersion in a weak acid, or physical squeezing.
- In this process **ordinary cell** thus gets **converted into pluripotent stem cell** which have the ability to form all types of adult cell types for e.g. cells of heart, brain, hands etc.
- It is an extremely simpler method of stem cell generation than previously researched methods.
- The technique for creating STAP cells in 2014 was discovered by **Charles** and **Martin Vacanti** and developed by **Haruko Obokata**.

12.1. RECENT CONTROVERSY ON STAP CELLS

- The finding of STAP cells by **Haruko Obokata** was recently called into questions because of the invalidity of the technique and reported anomaly in one of the pictures used for producing the research.
- The scientists have reported to use one of the images belonging to the old experiment for this new finding.
- Apart from this many of the scientists have reported inability to produce stem cells using the technique as mentioned in the research paper.
- This has led to the scientist taking back the published finding and working on improving the methods.

12.2. APPLICATIONS OF STAP CELLS

- It has the potential to produce cheap, fast, and flexible cells for use in regenerative medicine, medical treatments, and cloning.
- The STAP cells additionally claims that the tissues grown using STAP cells will genetically match to the patient's thus, prevent the risk of rejection by the immune system of the body.
- Considering their regenerative abilities, they can be used in treating diseases such as diabetes and heart problems.
- However, **Obokata's** findings are both controversial and not validated, despite attempts by multiple researchers.

13. MICROGRID

- A microgrid is a local energy grid with control capability, which means it can disconnect from the traditional grid and operate autonomously.

13.1. HOW DOES MICROGRID WORKS?

- To understand how a microgrid works, we first have to understand how the grid works.
- The grid connects homes, businesses and other buildings to central power sources, which allow us to use appliances, heating/cooling systems and electronics.
- But this interconnectedness means that when part of the grid needs to be repaired, everyone is affected.
- This is where a microgrid can help. A microgrid generally operates while connected to the grid, but importantly, it can break off and operate on its own using local energy generation in times of crisis like storms or power outages, or for other reasons.
- A microgrid can be powered by distributed generators, batteries, and/or renewable resources like solar panels. Depending on how it's fueled and how its requirements are managed, a microgrid might run indefinitely.

13.2. HOW DOES MICROGRID CONNECT TO THE GRID?

- A microgrid connects to the grid at a point of common coupling that maintains voltage at the same level as the main grid unless there is some sort of problem on the grid or other reason to disconnect.
- A switch can separate the microgrid from the main grid automatically or manually, and it then functions independently.

13.3. WHY MICROGRID IS NECESSARY?

- A microgrid not only provides backup for the grid in case of emergencies, but can also be used to cut costs, or connect to a local resource that is too small or unreliable for traditional grid use.

A microgrid allows communities to be more energy independent and, in some cases, more environmentally friendly.

14. SALVAGE THERAPY

- Salvage therapy, also known as **rescue therapy**, is a form of treatment given after an ailment does not respond to standard treatment.
- The most common diseases that require salvage therapy are HIV and various tumours.
- Salvage therapy drugs or drug combinations have, in general, **much more severe side effects** than the standard line of therapy.
- Government of India, under the National AIDS Control Programme-Phase IV(NACP-IV) has launched salvage therapy for treatment of HIV- AIDS.
- In this case it is also known as **third line therapy** and is prescribed for people who have limited drug options left and the first two drug regimens have failed to have any effect on the infection.
- Although this treatment is expensive, it is being given free of cost by the government.
- This treatment therapy would enhance the longevity and improve the quality of life of patients.

15. QR CODES

- QR or Quick Response Code are type of two dimensional (matrix) barcode that can be read using smartphones and dedicated QR reading devices, that link directly to text, emails websites phone numbers and more.

15.1. FEATURES OF QR CODE

- **High Capacity Encoding of Data:** While conventional bar codes are capable of storing a maximum of approximately 20 digits, QR Code can store up to 7089 digits.
- **Small Printout Size:** Since QR Code carries information both horizontally and vertically, QR Code is capable of encoding the same amount of data in approximately one-tenth the space of a traditional bar code. (For a smaller printout size, Micro QR Code is available).



- **Dirt and Damage Resistant:** QR Code has error correction capability. **Data can be restored** even if the symbol is partially dirty or damaged. A maximum 30% of codewords^{*1} can be restored^{*2}.



*1: A codeword is a unit that constructs the data area. In the case of QR Code, one codeword is equal to 8 bits.

*2: Data restoration may not be fully performed depending on the amount of dirt or damage.

- **Readable from any direction in 360°:** QR Code is capable of 360 degrees (omni-directional), high speed reading. QR Code accomplishes this task through position detection patterns located at the three corners of the symbol. These **position detection patterns** guarantee stable high-speed reading, circumventing the negative effects of background interference.

15.2. APPLICATIONS OF QR CODE:

- **Code payments:** QR codes can be used to store bank account information or credit card information, or they can be specifically designed to work with particular payment provider applications.
- **Website login:** QR codes can be used to log in into websites: a QR Code is shown on the login page on a computer screen, and when a registered user scans it with a verified smartphone, they will automatically be logged in on the computer. Authentication is performed by the smartphone which contacts the server.
- **Mobile operating systems:** QR codes can be used on various mobile device operating systems. These devices support URL redirection, which allows QR codes to send metadata to existing applications on the device. Many paid or free apps are available with the ability to scan the codes and hard-link to an external URL.
- **Providing real-time information:** QR codes can take customers to real-time updates anywhere where there is a constant flow of information. This could be anything from train stations and bus stops, to sales in department stores with the latest deals and offers, live events with updated speaker information, or even restaurant specials and booking

16. DISTRIBUTED MANUFACTURING

- In this process, the raw materials and methods of fabrication are decentralized, i.e., different parts are prepared at different places and the final product is manufactured very close to the final customer.
- While in traditional manufacturing, raw materials are brought together and turned into identical final products in large centralized factories and are then distributed to the customer.
- The idea is to replace as much of the material supply chain as possible with digital information.

16.1. HOW DOES IT WORK?

For example, to manufacture a chair, rather than sourcing wood and fabricating it into chairs in a central factory, digital plans for cutting the parts of a chair are distributed to local manufacturing hubs using computerized cutting tools known as CNC routers. Parts can then be assembled by the consumer or by local fabrication workshops that can turn them into finished products. One company already using this model is the US furniture company AtFAB.

16.2. BENEFITS:

- Reduction in logistics cost
- Innovation in products due to more and diverse people involved in manufacturing process
- More efficient use of resources, with less wasted capacity in centralized factories.
- Reduction of capital required
- More environment friendly

16.3. RISKS:

- It will disrupt traditional labour markets and the economics of traditional manufacturing.
- May be more difficult to regulate and control

17. HYBRID CARS

- Conventional cars use an internal combustion engine for power.
- Battery electric vehicles only use an electric motor and battery, eschewing conventional engines altogether.
- **Hybrid cars have the advantage of both of above type of vehicle.** They have, in addition to internal combustion engine, also an electric motor and a battery.
- If we had better batteries with greater power storage capacity, we would need hybrid cars.
- The most advanced hybrids have larger batteries and can recharge their batteries from an outlet. These are known as "plug-in hybrids" and can cover long distances.

17.1. BENEFITS:

- **Fuel Efficiency:** It greatly increases fuel efficiency by increasing mileage, turning off combustion engine while driving at lower speeds and when the car is stopped, battery provides power for air conditioning.
- While accelerating or at higher speeds, combustion engine can be used, thus not compromising with the power of vehicles.
- **Global Warming:** Will cut down emissions of global warming pollutants by a 1/3 to 1/2.
- It will greatly reduce dependence on fossil fuels.
- Later model may cut down these emissions even further.

18. SUPERBUGS

- "Superbugs" is a term used to describe strains of bacteria that are resistant to the majority of antibiotics commonly used today.
- For e.g. resistant bacteria that cause Pneumonia, Urinary tract infections, Skin infections, Multiple Drug-Resistant Tuberculosis (MDR-TB) etc.
- Antibiotic resistance is a naturally occurring phenomenon that can be slowed, but not stopped. Over time, bacteria adapt to the drugs that are designed to kill them, and evolve to ensure their survival.
- This makes previously standard treatments for bacterial infections less effective, and in some cases, ineffective.
- Certain actions may accelerate the emergence and spread of antibiotic-resistant bacteria, such as:
 - Using or misusing antibiotics
 - Having poor infection prevention and control practices
 - Living or working in unsanitary conditions
 - Mishandling food

18.1. HOW TO TACKLE RESISTANCE OF SUPERBUGS?

In 2014, the **WHO (World Health Organisation)** stated:

- People can help tackle resistance by:
 - using antibiotics only when prescribed by a doctor;
 - completing the full prescription, even if they feel better;
 - never sharing antibiotics with others or using leftover prescriptions.
- Health workers and pharmacists can help tackle resistance by:
 - enhancing infection prevention and control;
 - only prescribing and dispensing antibiotics when they are truly needed;
 - prescribing and dispensing the right antibiotic(s) to treat the illness.
- Policymakers can help tackle resistance by:
 - strengthening resistance tracking and laboratory capacity;
 - regulating and promoting appropriate use of medicines.
- Policymakers and industry can help tackle resistance by:
 - fostering innovation and research and development of new tools;
 - promoting cooperation and information sharing among all stakeholders.

19. PRECISE GENETIC-ENGINEERING TECHNIQUES

- Conventional genetic engineering has always created controversies, however, new techniques are emerging that allow us to directly "edit" the genetic code of plants.
- For example, to make them, more nutritious or better able to cope with a changing climate.
- Precise genetic engineering includes specific **mutations, insertions, and substitutions of genes and/or gene blocks** to introduce **new phenotypic traits** in the individuals to be genetically modified.
- In **PGE**, synthetic proteins can **precisely target locations** in the genome and make specific genetic changes.
- The method, which has previously been used in animals and in human cells, can be used to **introduce a new gene, make small changes in existing genes, or block a gene from being expressed in Plants cells also.**
- PGE makes it possible to **introduce several different genetic changes** into the plant.

19.1. WHY IT IS IMPORTANT:

- The technique not only allows for more precise changes, but it greatly **increases the efficiency of generating genetically engineered plants** for use as **food or fuel**, or for **absorbing carbon and cleaning the environment**.
- Precise genetic-engineering techniques will likely **solve some of the main controversial elements** in the GMO debate—for example, the fact that genetic engineering was not predictable.
- PGE will provide commercial **varieties with new traits of high agronomic value and/or high added value for industry or medicine**.

19.2. APPLICATION

Example:

- Effective against viruses and fungal pathogens, and can also protect plants against insect pests, reducing the need for chemical pesticides
- Benefit major staple-food crops, protecting wheat against stem rust, rice against blast, potato against blight and banana against fusarium wilt.

As such, genetic engineering may become less controversial, as people recognize its effectiveness at boosting the incomes and improving the diets of millions of people.

Taken together, these techniques promise to advance agricultural sustainability by reducing input use in multiple areas, from water and land to fertilizer, while also helping crops to adapt to climate change.

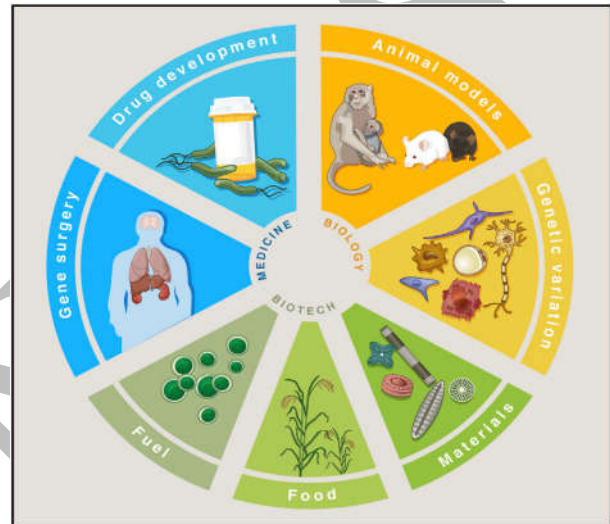

20. M5 SYNTHETIC PEPTIDE

- A team of Indian scientists at International Centre for Genetic Engineering and Biotechnology (ICGEB), New Delhi has developed a **Synthetic Peptide** molecule that prevents **malaria** and **tuberculosis** microbes from invading human cells.
- The molecule, **code-named M5**, works **against both infections** by targeting a key set of **proteins** in the human body that both the malaria parasite and the tuberculosis bacilli exploit to enter human blood cells and trigger the disease process.

20.1. SIGNIFICANCE

- This work raises the possibility of a novel strategy to **fight multiple infections**.
- The scientists believe their strategy could also be used to design molecules against viruses. Several viruses, including the **human immuno-deficiency virus** also rely on variants of proteins to enter human cells.
- It's an important breakthrough in the fight against **tropical diseases**, which is otherwise a neglected area for MNC's R&D.

20.2. CHALLENGES AND CONCERNS

- It is still **unclear** whether this strategy will really work in humans as clinical trials on humans are yet to prove their results.
- Much is unknown about the peptide at this stage, for example, whether it can be easily absorbed by the body or be happy in blood, whether it finds the right targets, has no **side effects or toxicity**.
- It can take a **decade or more, and cost** in the order of a billion dollars.

20.3. SIGNIFICANCE FOR INDIA

- India is the country with the highest burden of **TB**. **World Health Organisation (WHO)** statistics for 2013 gives an estimated incidence figure of 2.1 million cases of TB in India out of a global incidence of 9 million. It is estimated that about 40% of the Indian population is infected with TB bacteria.
- According to the **World Malaria Report 2014**, 0.88 million cases have been recorded in India. At present, official figures for malaria in India, are 0.7–1.6 million confirmed cases and 400-1,000 deaths annually.
- It may energise & boost the R&D in medicine in India.

However, the discovery of the drug candidate M5 synthetic peptide is the beginning of a long road and not the end. The process of drug discovery here is not yet complete, and has to be succeeded by more research and a host of clinical trials.

21. MRT (MITOCHONDRIAL REPLACEMENT THERAPY) TECHNIQUE

- Mitochondria provides human cells the energy they need to function.
- Genetic faults in the mitochondria can cause serious (potentially fatal) mitochondrial diseases affecting the organs and tissues that use energy including the brain, muscles heart and liver.
- MRT is used for treating the women with **mitochondrial disease**.
- In this technique the defective mitochondria carried by a woman is replaced with the healthy mitochondria of a donor. The egg is then fertilised with the partner's sperm through **in-vitro fertilization** technique. Thus the embryo remains free from any such defects. Thus it's an attempt to prevent the transmission of mitochondrial disease from one generation to the next.
- Mitochondrial Replacement Therapy, proposes to give women with mitochondrial DNA mutations an excellent chance of having a child that is over 99% genetically matched with her and her partner, and most importantly, is likely to be free of the mitochondrial disease.

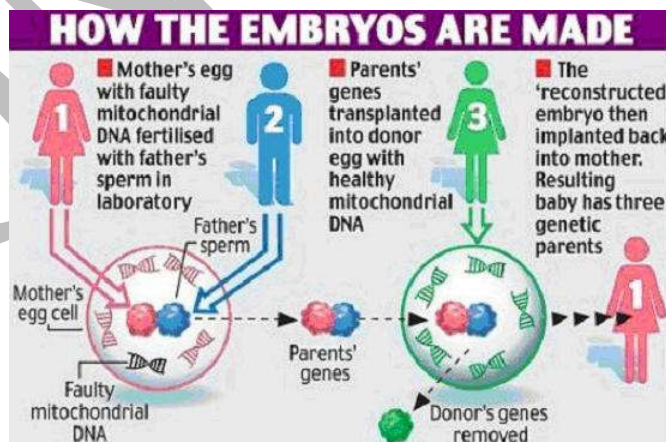

21.1. SIGNIFICANCE

- The parents can have a child who is 99.9% **genetically identical** to them.
- It will prevent **genetic disorders** (mitochondrial) from child birth itself.
- It may be helpful in reducing **Neo-Natal deaths and Infant Mortality rates** across the globe.
- Every individual has the **right to safe and effective health care**. Thus it would be a step in ensuring right to health of every individual.

21.2. SIGNIFICANCE FOR INDIA

- Current estimates place the incidence of mitochondrial disorder at about **1 in 2000 to 1 in 5000 live births** in India.
- India can reap the benefits of this technique in ensuring **right to health** to every citizen.
- India having **high IMR and neo-natal mortality** rates, it would be another instrument to reduce these rates.
- **Domestic violence** (child birth being one of the reason), could be reduced if children born are healthy

21.3. CONCERNS AND CHALLENGES

- Permission to this technique would increase the number of **human trials**. Thus it would be another instrument in the hands of MNCs to exploit the poor and disadvantaged.
- There are still health concerns about the fully safe procedure and its **long term** effects.
- There are **ethical and moral concerns** about using this technique on the future generation who are not aware of it.
- Further Some **religious institutions** are opposing it on the ground that it will be a **Three parent baby**, which will eventually lead to "**Frankenstein future**".
- It would not be helpful to those already suffering from mitochondrial disease, and the women with mitochondrial disease could have much safer alternatives, including pre-implantation genetic diagnosis and the use of third-party eggs with conventional IVF.

However, MRT is just another **technological innovation** and an expansion of existing in-vitro fertilization and not a genetic manipulation. The latest evidence indicates that mitochondrial replacement techniques are safe and effective in primates, although further research will be necessary to fully understand the long-term effects of MRT.

Thus the proposed **UK Bill** aimed at providing right to women of having Healthy Child is a right step in this regard. It may further inspire other nations and international efforts worldwide to look with a serious note on this new emerging technology.

22. EXASCALE COMPUTING

- Exascale computing refers to supercomputers capable of at least one exaFLOPS (a billion calculations) per second.
- Currently the fastest systems in the world perform between 10 and 33 petaflops, or ten to 33 million billion calculations per second – roughly one to three percent the speed of Exascale.
- Exascale computer is believed to be the order of processing power of the human brain at neural level.

22.1. WHY IN NEWS?

- In July, 2015, US President Barack Obama signed an order which is seen as a commitment of United States to build Exascale computers.
- According to experts, this decision was partially triggered by advances made by China in high performance computing.
- The world's top supercomputer, China's Tianhe-2, is nearly twice as powerful as the second place machine, Titan at Oak Ridge National Laboratory in Tennessee. And China recently announced plans to upgrade the Tianhe-2 machine to about 100 petaflops.

22.2. CHALLENGES:

- For this project, several agencies of US have come together because of increased budget requirement and complexity of the project.
- Reaching Exascale is expected to be far more difficult than simply wiring additional computer processors together.
- Tianhe-2 already uses 18 megawatts of power, enough to power 18,000 homes.
- Using that same technology to get to Exascale would require on the order of 540 megawatts, about the output of a nuclear power plant.

This computer when completed will immensely increase computation power and will allow for solving of some of the present problems which are complex even for existing supercomputers.

23. NEUROMORPHIC ENGINEERING/TECHNOLOGY

23.1. WHAT IS “NEUROMORPHIC TECHNOLOGY”?

- **Neuromorphic engineering / technology** is an interdisciplinary subject that takes inspiration from biology, physics, mathematics, computer science and electronic engineering to design artificial neural systems, such as vision systems, head-eye systems, auditory processors, and autonomous robots, whose physical architecture and design principles are based on those of biological nervous systems.
- **Neuromorphic engineering**, also known as **neuromorphic computing** is a concept developed by Carver Mead, in the late 1980s, describing the use of very-large-scale integration (VLSI) systems containing electronic analog circuits to mimic neuro-biological architectures present in the nervous system.
- A key aspect of neuromorphic engineering is to understand **how the morphology of individual neurons, circuits and overall architectures**
 - Creates desirable computations
 - How information is represented,
 - Incorporates learning and development,
 - Adapts to local change (plasticity),
 - And facilitates evolutionary change.
- In recent times the term neuromorphic has been used to describe analog, digital, and mixed-mode analog/digital VLSI and software systems that implement models of neural systems (for perception, motor control, or multisensory integration).
- The implementation of neuromorphic computing on the hardware level can be done by
 - **Oxide-based memristors** (A memristor is an electrical component that limits or regulates the flow of electrical current in a circuit and remembers the amount of charge that has previously flowed through it)
 - **Threshold switches.**
 - **Transistors.**

23.2. APPLICATIONS OF NEUROMORPHIC TECHNOLOGY:

- This technology can be use to increase the computing speed of super computers which are used in **weather forecasting**, in **defence services**, to develop and execute **complex algorithms** etc.
- It can be useful in **space technology** for outer space explorations as human body have limitations in outer space.

24. NEUROMORPHIC CHIPS

24.1. WHAT ARE NEUROMORPHIC CHIPS?

- Recently Qualcomm (company that designs and markets wireless telecommunications products) unveiled a pug-size robot- Pioneer.
- The robot is performing tasks that have typically needed powerful, specially programmed computers that use far more electricity.
- Powered by only a smart-phone chip with specialized software, Pioneer can recognize objects it hasn't seen before, sort them by their similarity to related objects—not because of laborious programming but only by being shown once where they should go.
- The robot can do all that because it is simulating, albeit in a very limited fashion, the way a brain works.
- IBM also designed a system called True North (using same chips) which is able to run "deep-learning" algorithms, similar to the facial recognition system being used by Facebook or the instant translate mode in Skype. System draws less electricity and takes less space than the Intel Processor.

	True North	Intel Processor
No. of Transistors used	5.4 billion transistors	1.4 billion transistors
Power use	70 milliwatt	between 35 and 140 watts

- The technology can be embedded into the **silicon chips** that power every manner of electronic device. These "**neuromorphic**" **chips**—so named because they are modeled on biological brains—will be designed to process sensory data such as images and sound and to respond to changes in that data in ways not specifically programmed.
- **Neuromorphic chips** are the computer chips that basically act as neurons.

24.2. USES OF NEUROMORPHIC CHIPS

This technology is still in developmental stages:

- The technology is useful in progress of artificial intelligence which will lead to machines that are able to understand and interact with the world in humanlike ways.
- Medical sensors and devices could track individuals' vital signs and response to treatments over time, learning to adjust dosages or even catch problems early.
- Our smart-phone could learn to anticipate what we want next, such as background on someone we're about to meet or an alert that it's time to leave for next meeting.

25. BRAIN MAPPING

- As part of the Human Brain Project, a team of scientists has produced a three-dimensional atlas of the brain that has 50 times the resolution of previous such maps.
- The team has devised a way to cut the brain into 20 micrometer-thick sections – far slimmer than the chunky 1 mm sections that have been available with magnetic resonance – dye them, scan them, and reconstruct the slices into a 3D "atlas" of the human brain.
- To guide the brain's digital reconstruction, researchers initially used an MRI machine to image the postmortem brain of a 65-year-old woman. The brain was then cut into ultrathin slices. The scientists stained the sections and then imaged them one by one on a flatbed scanner.
- It is a major step forward in understanding the brain's three-dimensional anatomy.

25.1. BENEFITS:

- It will give a better idea of where one region ends and the next begins, for a closer understanding of behavior-brain correspondence.
- It will also allow researchers to start making simulations, perhaps making it possible to “see” what happens in various disease states, say, in an Alzheimer’s- or Parkinson’s afflicted brain over time.
- It is expected to help in various other brain related diseases.

26.QUAKE PROOF BUILDING USING OLD TYRES

- Rubber has intrinsic capacity of absorbing vibrations.
- Rubber can be obtained from old tyres.
- Computer models show that when a mixture of crushed tyres and sands is used in the foundation of a building, the mixture could indeed help in reducing the vibration of seismic waves.
- This has the potential of not only making buildings in India earthquake resistant but also finding a solution to pollution caused due to burning or throwing away of old tyres in open.

27. BLACK ARSENIC-PHOSPHOROUS

- Silicon technology has provided with tinier transistors for smaller and smaller devices.
- But this technology is reaching its limit with smaller size.
- An alternative to silicon is seen as Graphene- which is only one atom thick sheet of carbon with desirable electrical properties, strength and flexibility.
- However, Black arsenic phosphorous – a material in which individual phosphorus atoms are replaced by arsenic, could become a competing alternative to graphene.
- Like graphene, it forms extremely thin layers.
- Possible applications range from transistors and sensors to mechanically flexible semiconductor devices.
- More importantly, unlike graphene, whose electronic properties are similar to those of metals, black arsenic phosphorus behaves like a semiconductor.

28. BRAIN NET

- Scientists have been able to establish a direct brain-to-brain connection between pairs of human participants.
- The participants were able to play a question and answer game while situated almost 1.5 Km apart.
- The brain signals are captured through electroencephalography (EEG) machine that records electrical brain activity which is then sent over the internet.
- Earlier, scientists were successful in linking together brains of three monkeys, allowing the animals to join forces and control an avatar arm.
- In a second experiment, the brains of four rats were wired together in what may be termed as a “brain net”.
- Present experiment involving human participants shows that two brains can be linked together to allow one person to guess what’s on other person’s mind.
- In future, it can lead to creation of super-brain - a collective brain created from many brains linked together in a brain net.

29. NANO ARCHITECTURE

- Scientists through Nano-architecture have created a ceramic which is as strong as traditional ceramics, but at a fraction of weight of ceramics and not brittle as ceramics.
- Ceramics are strong, heavy, and brittle, prone to breaking.
 - Ceramics are used in a number of applications which includes, structural usage- bricks, pipes etc., whitewares – cookware, wall tiles, pottery products, sanitary ware etc., and Technical usage – gas burner nozzle, biomedical implants etc.
- These new materials are made up of nanoscale trusses (framework of beams) crisscrossed like struts (a net like structure)- but each struts walls are only about 10 nanometers thick.
- On applying pressure upon these new ceramics, they shudder, get deformed, but on removing the pressure, the material gets back to its original shape – that is the magic of nanomaterial.

29.1. POTENTIAL BENEFITS:

- If produced in large quantities, they can replace conventional ceramics in many applications because they would be just as strong at a fraction of the weight.
- Energy density of batteries, i.e., amount of power they can hold at a given size can be greatly increased.
- It could help in light emitting materials or thermal insulation to precisely control flow of light or heat.
- It can also prove very beneficial to biomedical field by producing tiny and light yet very strong materials.

30. AGRICULTURAL DRONES

- Agricultural drones are UAVs used in modern farming that uses big data, aerial imagery and other means to optimise efficiency.
- These drones are equipped with an autopilot using GPS and a standard point-and-shoot camera controlled by the autopilot; software on the ground can stitch aerial shots into a high-resolution mosaic map.

30.1. BENEFITS OVER OTHER TECHNOLOGICAL ALTERNATIVES:

- It does not require a pilot on the ground as is required in traditional radio-controlled small aircrafts.
- Its software plans the flight path, aiming for maximum coverage of the farm, and controls the camera to optimize the images for later analysis.
- Compared with satellite imagery, it's much cheaper and offers higher resolution. Because it's taken under the clouds, it's unobstructed and available anytime.
- It's also much cheaper than crop imaging with a manned aircraft.
- This progress has been made possible largely due to advances in tiny sensors, small GPS modules, incredibly powerful processors, and a range of digital radios.

30.2. THREE TYPES OF DETAILED VIEWS AND ATTACHED BENEFITS:

- First, seeing a crop from the air can reveal patterns that expose everything from irrigation problems to soil variation and even pest and fungal infestations that aren't apparent at eye level.
- Second, airborne cameras can take multispectral images, capturing data from the infrared as well as the visual spectrum, which can be combined to create a view of the crop that highlights differences between healthy and distressed plants in a way that can't be seen with the naked eye.
- Finally, a drone can survey a crop every week, every day, or even every hour. Combined to create a time-series animation, that imagery can show changes in the crop, revealing trouble spots or opportunities for better crop management.

30.3. USAGES IN INDIA:

- Few pilot projects have been reported to be conducted in parts of Rajasthan and Gujarat to see how drones can be used to survey crops and help map crop diseases along with helping insurance companies settle claims.
- This technology has immense potential to help agriculture increase its yield by providing timely and precise information about various factors affecting crops.

31. LIGHT BASED TECHNOLOGIES

31.1. OPTOGENETICS: CONTROLLING NEURONS WITH LIGHT:

- **Optogenetics** – the technique uses light to precisely control the activity of specific neurons (specialized cells transmitting nerve impulses) in living organisms, even moving animals in real time.
- Such precision is necessary for studying the hundreds of different neuron types and for understanding higher brain functions such as thought, behaviour, language, memory – or even mental disorders.
- The method involves **genetic modification of neurons** so that they produce a light-sensitive protein. Sitting on the outside of the cell, the protein acts as an electrical channel – a kind of gate.
- When light is shone on the cell, the channel opens and allows ions to flow into the neuron, creating an electrical charge. It's a bit like a battery being charged by a solar cell.
- The electrical charge changes the voltage balance of the neuron and – if strong enough – generates an explosive electrical signal. **So optogenetics enables scientists to control the activity of neurons by switching a light on and off.**

31.2. LI-FI- LED BASED WI-FI:

- Li-Fi is an OWC (Optical Wireless Communications) technology, uses light from light-emitting diodes (LEDs) as a medium to deliver networked, mobile, high-speed communication in a similar manner to Wi-Fi.
- Li-Fi could lead to the Internet of Things, which is everything electronic things being connected to the internet, with the LED lights on the electronics being used as Li-Fi internet access points.
- Visible light communications (VLC) works by switching bulbs on and off within nanoseconds, which is too quickly to be noticed by the human eye.
- Although Li-Fi bulbs would have to be kept on to transmit data, the bulbs could be dimmed to the point that they were not visible to humans and yet still functional.
- The light waves cannot penetrate walls which makes a much shorter range, though more secure from hacking, relative to Wi-Fi.
- Direct line of sight isn't necessary for Li-Fi to transmit a signal; light reflected off the walls can achieve 70 Mbit/s.
- Li-Fi has the advantage of being useful in electromagnetic sensitive areas such as in aircraft cabins, hospitals etc, without causing electromagnetic interference.
- Both Wi-Fi and Li-Fi transmit data over the electromagnetic spectrum, but whereas Wi-Fi utilizes radio waves, Li-Fi uses visible light.
- The visible light spectrum is 10,000 times larger than the entire radio frequency spectrum. Researchers have reached data rates of over 10 Gbit/s, which is more than 250 times faster than superfast broadband.
- Li-Fi is expected to be ten times cheaper than Wi-Fi. Short range, low reliability and high installation costs are the potential downsides.

31.3. SIMULATING SUNLIGHT TO BOOST ALGAE POWER:

- A public-private partnership in Germany has developed a novel LED-based technology to optimise the growth and productivity of algae, which could help meet the world's demand for energy in the form of **biofuel**.
- Because food crops are also used for energy production, millions of people are threatened by starvation.
- However, algae could provide an alternative: they thrive in harsh conditions and need only sunlight to grow.
- A major challenge, though, is to exactly reproduce sunlight in the laboratory. However even this problem is now solved by researchers who are now able to simulate all kinds of light situations using LEDs.

32. EMERGENT ARTIFICIAL INTELLIGENCE (EAI)

32.1. UNDERSTANDING EAI

- Artificial intelligence is the branch of computer science concerned with making computers behave like humans. In contrast to normal hardware and software, AI enables a machine to perceive and respond to its changing environment.
- While in **Emergent AI** machines **learn automatically (like human do)** during their processing by assimilating large volumes of information.
- For example, **NELL** (the Never-Ending Language Learning project), a computer system that not only reads facts by from hundreds of millions of web pages, but attempts to improve its reading and understanding competence in the process in order to perform better in the future.

32.2. APPLICATIONS OF EMERGENT AI

- **Transport:** There is substantial evidence that self-driving cars will reduce collisions, and resulting deaths and injuries, from road transport, as machines avoid human errors like lapses in concentration and defects in sight, among other problems.
- **Medical Profession:** Intelligent machines, having faster access to a much larger store of information and able to respond without human emotional biases, might also perform better than medical professionals in diagnosing diseases. The Watson (an AI computer system) is now being deployed in oncology to assist in diagnosis and personalized, evidence-based treatment options for cancer patients.
- **Intelligent Surveillance Systems:** Surveillance systems that include video analytics (EAI) analyze video footage in real-time and detect abnormal activities that could pose a threat to an organization's security. Essentially, video analytics technology helps security software "learn" what is normal so it can identify unusual, and potentially harmful, behavior that a human alone may miss.
- **Virtual Customer Service Agents:** As software advances, the sophistication and perception of virtual customer care agents will radically change. Computers will fully emulate human beings and will recognize emotion and mood.
- **Medicine:** Applications in personalized medicine for deducing expected prognosis and guiding treatment planning.

33. "SENSE AND AVOID" DRONES

- Unmanned aerial vehicles, or drones, have become an important part of military capacity in recent years. But so far all these drones have had human pilots; the difference with respect to aircrafts is that their pilots are on the ground and fly the aircraft remotely.

- The next step in drone technology is to develop machines that fly themselves, opening them up to a wider range of applications.
- For this to happen, drones must be able to sense and respond to their local environment, altering their height and flying trajectory in order to avoid colliding with other objects in their path.
- In nature, birds, fish and insects can all congregate in swarms, each animal responding to its neighbour almost instantaneously to allow the swarm to fly or swim as a single unit. Drones can emulate this.
- In January 2014, Intel and Ascending Technologies showcased prototype multi-copter drones that could navigate an on-stage obstacle course and automatically avoid people who walked into their path. The machines use **Intel's RealSense camera module**. Drones are essentially robots operating in three, rather than two dimensions.

33.1. APPLICATIONS OF "SENSE AND AVOID" DRONES

- With reliable autonomy and collision avoidance, drones can begin to take on tasks too dangerous or remote for humans to carry out:
 - Checking electric power lines.
 - Delivering medical supplies in an emergency. Drone delivery machines will be able to find the best route to their destination, and take into account other flying vehicles and obstacles.
 - In agriculture, autonomous drones can collect and process vast amounts of visual data from the air, allowing precise and efficient use of inputs such as fertilizer and irrigation.
 - Collision avoidance will usher in a future of shared airspace, with many drones flying in proximity to humans and operating in and near the built environment to perform a multitude of tasks.
 - Moreover, sense and avoid drones will be able to operate reliably in the most difficult conditions: at night, in blizzards or dust storms.

34. LIQUID BIOPSY

- A technique which is meant to detect liver and other cancers very early- even before symptoms arise- by sequencing the DNA in a few drops of a person's blood.
- That's possible because dying cancer cells also shed DNA into a person's blood. At early stages of cancer, the amount is vanishingly small. That makes it difficult to measure.
- The approach relies on gene-sequencing machines, which rapidly decode millions of short fragments of DNA that are loose in the bloodstream.
- The results are compared with the reference map of the human genome. Researchers can then spot the specific patterns of rearranged DNA that are telltale signs of a tumor.
- For the time being, the cost of the DNA test being tried out on people at risk for liver cancer is still too high for routine use. But with spread of technology it is expected to come down.

34.1. BENEFITS

Screening for Cancer at an early stage:

- Cancers detected at an advanced stage, when they are spreading, remain largely untreatable.
- In the United States, early detection is behind medicine's most notable successes in applying technology to cut deaths from common cancers.
- In research, among the first 10,000 men screened, the researchers picked up 17 cases of cancer—13 of those at stage I, the earliest kind.
- Nearly all these men have now beaten the cancer with radiation treatment.
- The typical survival rate is less than 70 percent if patients seek out a doctor only when they have the most advanced symptoms, like a mass in the neck.

- Researchers are trying whether these ideas can turn into a general-purpose test for nearly any cancer, not only those involving a virus.

Improvement in curing cancer:

- In addition to screening for cancer, liquid biopsies could be a way to help people already fighting the disease.
- Doctors can pick a drug according to the specific DNA mutation driving a cancer forward.
- Tests to identify the mutation are sometimes done on tissue taken from a tumor, but a noninvasive blood test would be appropriate in more cases.

35. SPACE-BASED SOLAR POWER

- Space-based solar power (SBSP) is an idea of collecting solar power in space for use on Earth.
- SBSP would differ from current solar collection methods in that the means used to collect energy would reside on an orbiting satellite instead of on Earth's surface.
- Part of the solar energy is lost on its way through the atmosphere by the effects of reflection and absorption. Space-based solar power systems convert sunlight to microwaves outside the atmosphere, avoiding these losses, and the downtime (and cosine losses, for fixed flat-plate collectors) due to the Earth's rotation.

35.1. ADVANTAGES

- The SBSP concept is attractive because space has several major advantages over the Earth's surface for the collection of solar power.
- There is no air in space, so the collecting surfaces could receive much more intense sunlight, unobstructed by the filtering effects of atmospheric gasses, cloud cover, and other weather events. Consequently, collection in orbit is approximately 144% of the maximum attainable on Earth's surface.
- A satellite could be illuminated over 99% of the time, and be in Earth's shadow on only 75 minutes per night at the spring and fall equinoxes. Orbiting satellites can be exposed to a consistently high degree of solar radiation, generally for 24 hours per day, whereas surface panels can collect for 12 hours per day at most.
- Relatively quick redirecting of power directly to areas that need it most. A collecting satellite could possibly direct power on demand to different surface locations based on geographical baseload or peak load power needs.
- Elimination of plant and wildlife interference.

35.2. DISADVANTAGES

- The SBSP concept also has a number of problems.
- The large cost of launching a satellite into space
- **Inaccessibility:** Maintenance of an earth-based solar panel is relatively simple, but performing maintenance on a solar panel in space incurs the extra cost of transporting a team of astronauts into space.
- The space environment is hostile; panels suffer about 8 times the degradation they would on Earth. System lifetimes on the order of a decade would be expected, which makes it difficult to produce enough power to be economical.
- Space debris is a major hazard to large objects in space, and all large structures such as SBSP systems have been mentioned as potential sources of orbital debris.
- The broadcast frequency of the microwave downlink (if used) would require isolating the SBSP systems away from other satellites. GEO space is already well used and it is considered unlikely the ITU would allow an SPS to be launched.

36. HIGH TEMPERATURE SUPERCONDUCTORS

- High-temperature superconductors (High-T_c or HTS) are materials that behave as superconductors at unusually high temperatures.
- The first High-T_c superconductor was discovered in 1986 by IBM researchers Karl Müller and Johannes Bednorz, who were awarded the 1987 Nobel Prize in Physics "for their important break-through in the discovery of superconductivity in ceramic materials".
- Whereas "ordinary" or metallic superconductors usually have transition temperatures (temperatures below which they superconduct) of about 30 K (−243.2 °C), HTS superconductors have been observed with transition temperatures as high as 138 K (−135 °C).
- Until recently, only certain compounds of copper and oxygen (so-called "cuprates") were believed to have HTS properties, and the term high-temperature superconductor was used interchangeably with Cuprate superconductor. However, several Iron based compounds are now known to be superconducting at high temperatures.
- The high temperature superconductors represent a new class of materials which bear extraordinary superconducting and magnetic properties and great potential for wide-ranging technological applications. The importance of understanding the transport and magnetic behaviors of these novel materials is two-fold. First, it could lead to a better understanding of the basic phenomena of superconductivity in these materials. Second, it could provide ways to improve the magnetic quality of the presently known materials by enhancing flux pinning in a controllable manner.

37. CARBON NANOTUBES (CNT)

- Carbon nanotubes (CNTs) are allotropes of carbon with a cylindrical nanostructure. Nanotubes have been constructed with length-to-diameter ratio of up to 132,000,000:1, significantly larger than for any other material. These cylindrical carbon molecules have unusual properties, which are valuable for nanotechnology, electronics, optics and other fields of materials science and technology. In particular, owing to their extraordinary thermal conductivity and mechanical and electrical properties, carbon nanotubes find applications as additives to various structural materials.

37.1. STRUCTURE

- The bonding in carbon nanotubes is sp², with each atom joined to three neighbours, as in graphite. The tubes can therefore be considered as rolled-up graphene sheets (graphene is an individual graphite layer). There are three distinct ways in which a graphene sheet can be rolled into a tube.
- Carbon nanotubes are long chains of carbon held together by the strongest bond in all chemistry, the sacred sp² bond, even stronger than the sp³ bonds that hold together diamond. Carbon nanotubes have numerous remarkable physical properties, including ballistic electron transport (making them ideal for electronics) and so much tensile strength that they are the only substance that could be used to build a space elevator. The

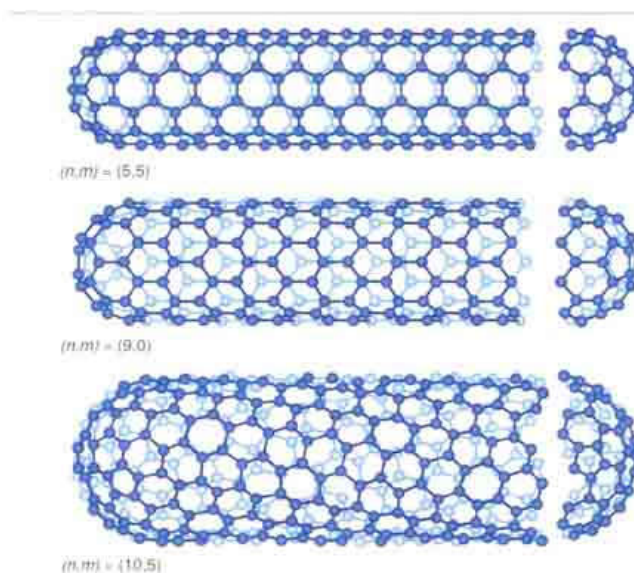

specific strength of carbon nanotubes is 48,000 kN·m/kg, the best of known materials, compared to high-carbon steel's 154 kN/kg. That's 300 times stronger than steel. You could build towers hundreds of kilometres high with it.

- Carbon Nanotube Technology can be used for a wide range of new and existing applications:
 - Conductive plastics
 - Structural composite materials
 - Flat-panel displays
 - Gas storage
 - Antifouling paint
 - Micro- and nano-electronics
 - Radar-absorbing coating
 - Technical textiles
 - Ultra-capacitors
 - Atomic Force Microscope (AFM) tips
 - Batteries with improved lifetime
 - Biosensors for harmful gases
 - Extra strong fibers

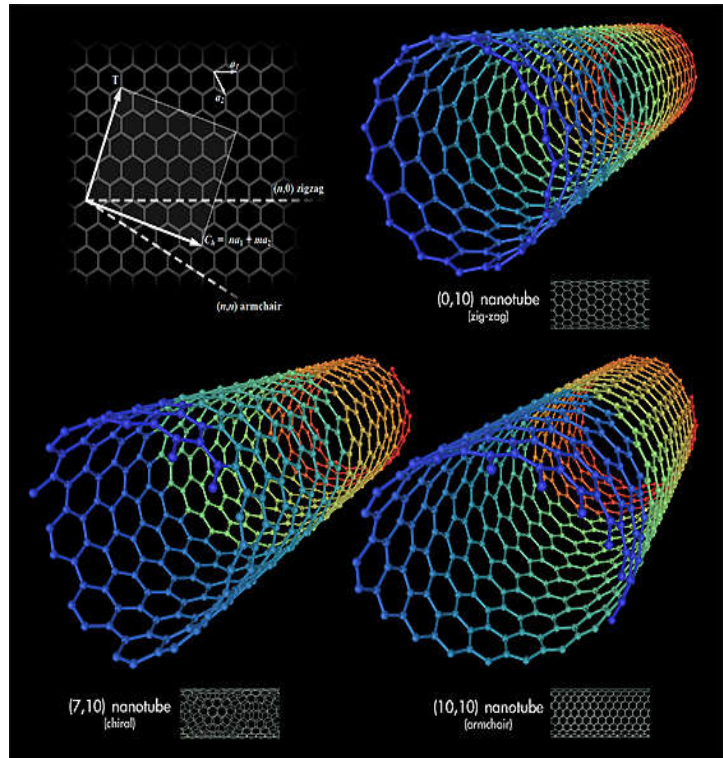

38. MAGLEV BULLET TRAIN

- Also called 'floating' trains as there is lack of friction due to the new maglev technology which makes acceleration and deceleration faster and they are unaffected by weather conditions.
- Japan has successfully performed the first successful test of new generation L0 Series Trains (maglev bullet trains) designed to travel at speeds of 311 mph.
- These trains have latest Magnetic levitation technology (maglev) instead of the conventional wheels.

38.1. MAGNETIC LEVITATION TECHNOLOGY (MAGLEV)

- Maglev (derived from magnetic levitation) is a method of propulsion that uses magnetic levitation to propel vehicles with magnets rather than with wheels, axles and bearings.
- With maglev, a vehicle is levitated a short distance away from a guide way using magnets to create both lift and thrust.

39. REGENERATIVE MEDICINE

- Regenerative medicine helps natural healing processes to work faster and better. These technologies and techniques create an environment in which missing or damaged tissue that would not ordinarily regrow in fact regenerates fully.
- Strategies presently under development include transplants of stem cells, the manipulation of the patient's own stem cells, and the use of scaffold materials that emit biochemical signals to spur stem cells into action. Regenerative therapies have been demonstrated (in trials or the laboratory) to heal broken bones, bad burns, blindness, deafness, heart damage, nerve damage, Parkinson's disease, and a range of other conditions. Work continues to bring these advances to patients.

40. QUANTUM COMPUTER

- A quantum computer is a computer design which uses the principles of quantum physics to increase the computational power beyond what is attainable by a traditional computer. Quantum computers have been built on the small scale and work continues to upgrade them to more practical models.
- Computers function by storing data in a binary number format, which result in a series of 1s & 0s retained in electronic components such as transistors. Each component of computer memory is called a bit and can be manipulated through the steps of Boolean logic so that the bits change, based upon the algorithms applied by the computer program, between the 1 and 0 modes.

A quantum computer, on the other hand, would store information as either a 1, 0, or a quantum superposition of the two states. Such a "quantum bit," called a qubit, allows for far greater flexibility than the binary system.

41. SOLAR PHOTOVOLTAIC TECHNOLOGIES

Solar photovoltaic technologies convert solar energy into useful energy forms by directly absorbing solar photons—particles of light that act as individual units of energy—and either converting part of the energy to electricity (as in a photovoltaic (PV) cell) or storing part of the energy in a chemical reaction (as in the conversion of water to hydrogen and oxygen).

41.1. SOLAR CELLS

- Solar cells are devices that convert sunlight directly into electricity.
- Solar cells are made of layers of semiconductor materials similar to those used in computer chips.
- When sunlight is absorbed by these materials, the solar energy knocks electrons loose from their atoms, allowing the electrons to flow through the material to produce electricity.

41.2. SOLAR ARRAYS

- Solar cells are generally very small, and each one may only be capable of generating a few watts of electricity.
- They are typically combined into modules of about 40 cells; the modules are in turn assembled into PV arrays up to several meters on a side.
- These flat-plate PV arrays can be mounted at a fixed angle facing south, or they can be mounted on a tracking device that follows the sun, allowing them to capture more sunlight.
- For utility-scale electricity generating applications, hundreds of arrays are interconnected to form a single, large system.

41.3. CONCENTRATED PV (CPV) SYSTEMS

- Concentrated PV (CPV) systems concentrate sunlight on solar cells, greatly increasing the efficiency of the cells.
- The PV cells in a CPV system are built into concentrating collectors that use a lens or mirrors to focus the sunlight onto the cells.
- CPV systems must track the sun to keep the light focused on the PV cells.
- The primary advantages of CPV systems are high efficiency, low system cost, and low capital investment to facilitate rapid scale-up; the systems use less expensive semiconducting PV material to achieve a specified electrical output.
- Reliability, however, is an important technical challenge for this emerging technological approach; the systems generally require highly sophisticated tracking devices.

42. NEAR FIELD COMMUNICATION (NCF)

- Near Field Communication (NFC) is a wireless connectivity technology that enables convenient short-range communication between electronic devices. It allows for simplified transactions, data exchange, and wireless connections between two devices in close proximity to each other, usually by no more than a few centimetres. The technology allows short-range data transfer, usually at a distance of 10 cm or less.

Comparison with Bluetooth:

Tag requires power	No	Yes
Cost of tag	6 Rs.	300 Rs
Frequency	13.56 MHz	2.4–2.5 GHz
Set Up time	< 0.1 s	< 6 s
Bit rate	424it/s	2.1 Mbit/s

42.1. APPLICATIONS

1. An NFC enabled device can work as an RFID (radio frequency identification) tag scanner
2. This new technology has the potential to replace plastic money with a phone
3. Thirdly, NFC-enabled phones can be used to easily exchange data.

With NFC, you can easily bring devices together to be automatically prompted to initiate Bluetooth pairing by a tap on each screen.

43. DESIGNER BABY

- The word designer baby has been defined in Oxford dictionary as a baby whose genetic makeup has been artificially selected by genetic engineering combined with in vitro fertilisation to ensure the presence or absence of particular genes or characteristics.
- The technology behind designer babies is based on Pre-Implantation Genetic Disorder (PGD). The embryo is created through in Vitro Fertilisation (IVF). A single cell is removed from the embryo within five days, and it is then genetically tested. The parents then decide whether to discard the embryo or implant it.

44. BIOSIMILAR

- The term biosimilar refers to products that are marketed after expiration of patents, which are claimed to have similar properties to existing biologic products. Due to the complexity of biologics, a product can only be made that is similar, but not identical.
- Biosimilars are generic impersonations (although not identical copies) of biotech drugs.
- Manufacturing processes for biologics differ greatly from the manufacturing processes for small molecule drugs.

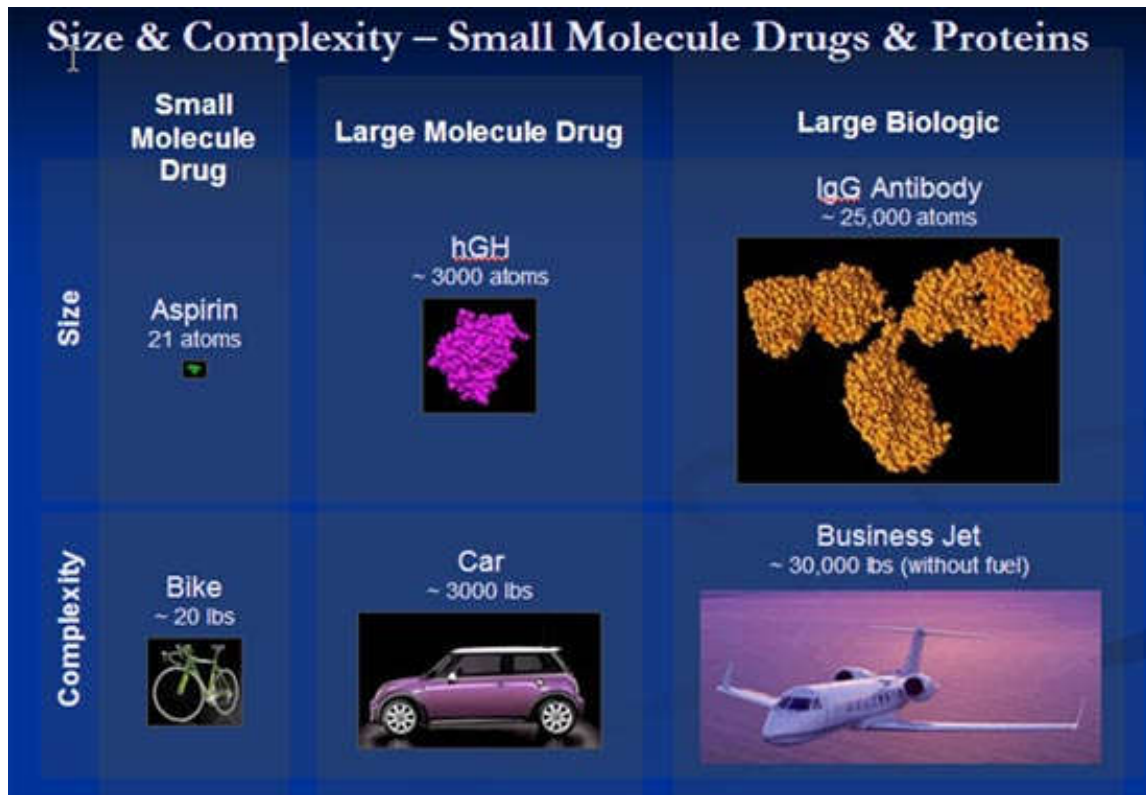

45. VERTICAL FARMING- (FARM VERTICALLY)

- Vertical farming is a proposal to build high rise buildings within urban areas to enable the growing of food crops to help avoid the impending food shortage which is envisaged in the near future.
- It is thought that by the year 2050 the world's population will have grown by a further 3 billion people and with more land needed than is available to grow the crops needed to feed everybody, ideas have to be considered to how these extra crops can be grown.
- Vertical farming could provide year round food production and better crop production, being able to yield more produce by area like for like compared to traditional horizontal farming. To put in a nutshell vertical farming is like a high rise greenhouse, sometimes having the label farmscrapers.

45.1. ADVANTAGES OF VERTICAL FARMING

- Year-round crop production; 1 indoor acre is equivalent to 4-6 outdoor acres or more, depending upon the crop (e.g., strawberries: 1 indoor acre = 30 outdoor acres)
- No weather-related crop failures due to droughts, floods, pests
- All VF food is grown organically: no herbicides, pesticides, or fertilizers
- VF virtually eliminates agricultural runoff by recycling black water
- VF returns farmland to nature, restoring ecosystem functions and services
- VF greatly reduces the incidence of many infectious diseases that are acquired at the agricultural interface
- VF converts black and grey water into potable water by collecting the water of evapotranspiration
- VF adds energy back to the grid via methane generation from composting non-edible parts of plants and animals.
- VF dramatically reduces fossil fuel use (no tractors, plows, shipping.)
- VF converts abandoned urban properties into food production centers
- VF creates sustainable environments for urban centers
- VF creates new employment opportunities
- We cannot go to the moon, Mars, or beyond without first learning to farm indoors on earth

- VF may prove to be useful for integrating into refugee camps
- VF offers the promise of measurable economic improvement for tropical and subtropical LDCs. If this should prove to be the case, then VF may be a catalyst in helping to reduce or even reverse the population growth of LDCs as they adopt urban agriculture as a strategy for sustainable food production.
- VF could reduce the incidence of armed conflict over natural resources, such as water and land for agriculture



46. STEM CELL TREATMENTS

- Stem cell treatments are a type of intervention strategy that introduces new adult stem cells into damaged tissue in order to treat disease or injury. Many medical researchers believe that stem cell treatments have the potential to change the face of human disease and alleviate suffering. The ability of stem cells to self-renew and give rise to subsequent generations with variable degrees of differentiation capacities, offers significant potential for generation of tissues that can potentially replace diseased and damaged areas in the body, with minimal risk of rejection and side effects.
- But there is widespread controversy over the use of human embryonic stem cells. This controversy primarily targets the techniques used to derive new embryonic stem cell lines, which often requires the destruction of the blastocyst. Opposition to the use of human embryonic stem cells in research is often based on philosophical, moral or religious objections.

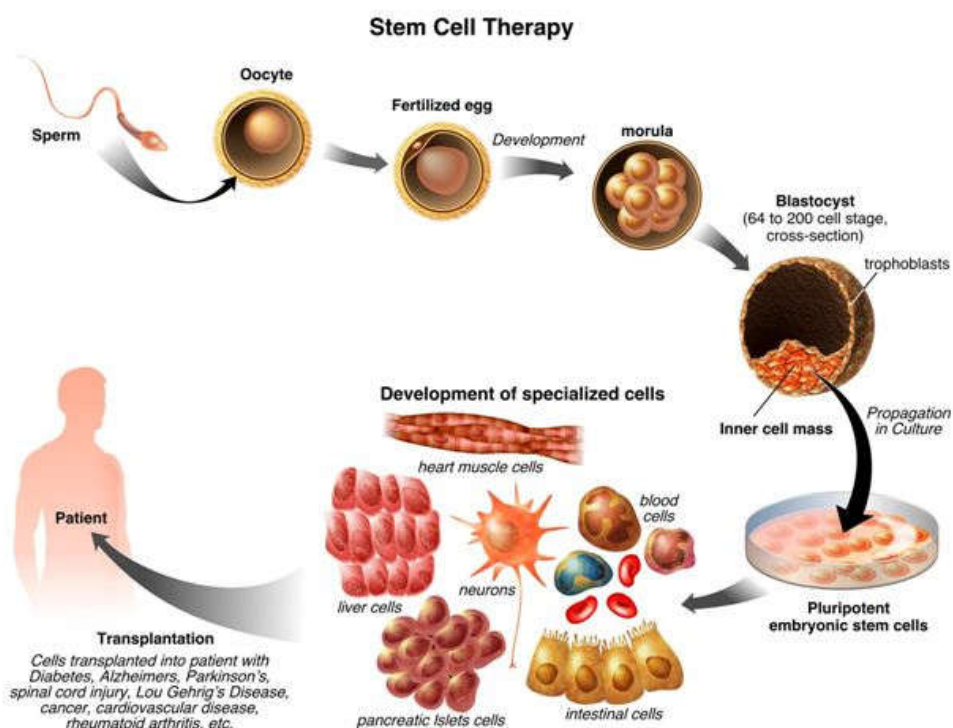

47. ROBOTIC SURGERY

- Robotic surgery is a technique in which a surgeon performs surgery using a computer that remotely controls very small instruments attached to a robot.
- The surgeon first inserts these instruments into your body through small surgical cuts. Under the surgeon's direction, the robot matches the doctor's hand movements to perform the procedure using the tiny instruments.
- A thin tube with a camera attached to the end of it (endoscope) allows the surgeon to view highly magnified three-dimensional images of your body on a monitor in real time.
- Major advances aided by surgical robots have been remote surgery, minimally invasive surgery and unmanned surgery. Some major advantages of robotic surgery are precision, miniaturization, smaller incisions, decreased blood loss, less pain, and quicker healing time. Further advantages are articulation beyond normal manipulation and three-dimensional magnification, resulting in improved ergonomics. Robotic techniques are also associated with reduced duration of hospital stays, blood loss, transfusions, and use of pain medication.

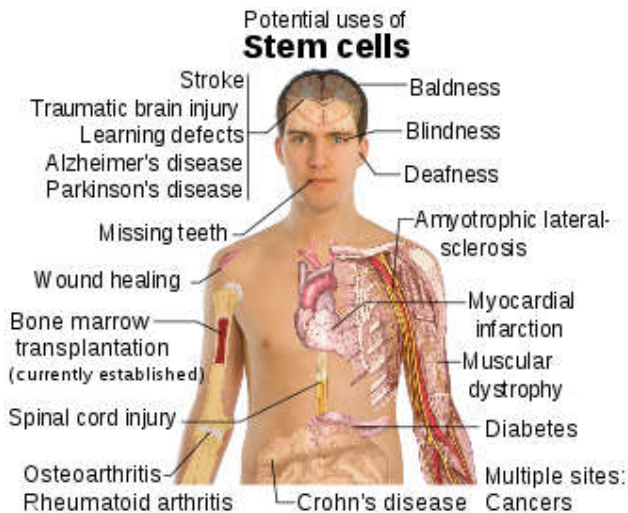

48. PERSONALIZED MEDICINE

- Personalized medicine is a young but rapidly advancing field of healthcare that is informed by each person's unique clinical, genetic, genomic, and environmental information. Because these factors are different for every person, the nature of diseases—including their onset, their course, and how they might respond to drugs or other interventions—is as individual as the people who have them.
- Personalized medicine is about making the treatment as individualized as the disease. It involves identifying genetic, genomic, and clinical information that allows accurate predictions to be made about a person's susceptibility of developing disease, the course of disease, and its response to treatment.
- Specific advantages that personalized medicine may offer patients and clinicians include:
 - Ability to make more informed medical decisions
 - Higher probability of desired outcomes thanks to better-targeted therapies
 - Reduced probability of negative side effects
 - Focus on prevention and prediction of disease rather than reaction to it
 - Earlier disease intervention than has been possible in the past
 - Reduced healthcare cost

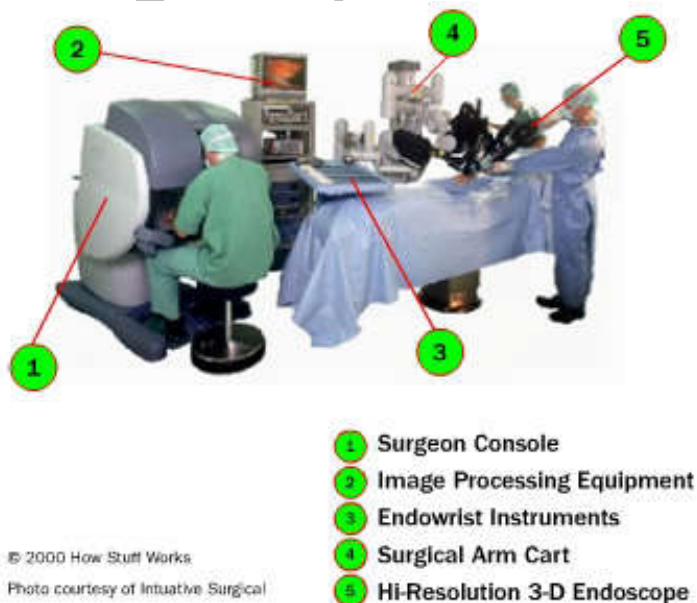

49. CLAYTRONICS

- Claytronics is an abstract future concept that combines nanoscale robotics and computer science to create individual nanometer-scale computers called claytronic atoms, or catoms, which can interact with each other to form tangible 3-D objects that a user can interact with. This idea is more broadly referred to as programmable matter. Claytronics has the potential to greatly affect many areas of daily life, such as telecommunication, human-computer interfaces, and entertainment.

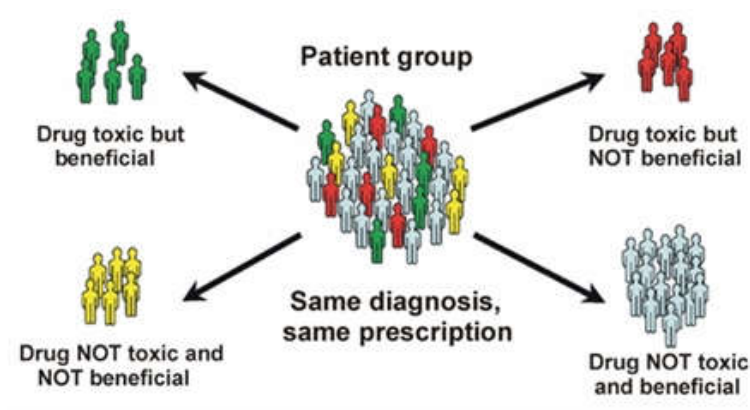

- Catoms—for claytronic atoms—that can move in three dimensions (in relation to other catoms), adhere to other catoms to maintain a 3D shape, and compute state information (with possible assistance from other catoms in the ensemble). Each catom contains a CPU, an energy store, a network device, a video output device, one or more sensors, a means of locomotion, and a mechanism for adhering to other catoms.
- The power and flexibility that will arise from being able to "program" the world around us should influence every aspect of the human experience. Claytronics is a technology which can serve as the means of implementing a new communication medium, which we call pario. The idea behind pario is to reproduce moving, physical 3D objects. Similar to audio and video, we are neither transporting the original phenomena nor recreating an exact replica: instead, the idea is to create a physical artefact that can do a good enough job of reproducing the shape, appearance, motion, etc., of the original object that our senses will accept it as being close enough.

As of 2006 researchers have already created a prototype catom that is 44 millimeters in diameter. The goal is to eventually produce catoms that are one or two millimeters in diameter—small enough to produce convincing replicas.

50. CHEMICAL COMPUTER

- A chemical computer, also called reaction-diffusion computer, BZ computer (stands for Belousov–Zhabotinsky computer) or gooware computer is an unconventional computer based on a semi-solid chemical "soup" where data are represented by varying concentrations of chemicals.
- The computations are performed by naturally occurring chemical reactions.
- The simplicity of this technology is one of the main reasons why it in the future could turn into a serious competitor to machines based on conventional hardware.
- A modern microprocessor is an incredibly complicated device that can be destroyed during production by no more than a single airborne microscopic particle.

51. QUANTUM DOT DISPLAY/QLED OR QDLED

- QD LED or QLED is considered as a next generation display technology after OLED-Displays.
- QLED means Quantum dot light emitting diodes and are a form of light emitting technology and consist of nano-scale crystals that can provide an alternative for applications such as display technology. The structure of a QLED is very similar to the OLED technology. But the difference is that the light emitting centers are cadmium selenide (CdSe) nanocrystals, or quantum dots. A layer of cadmium-selenium quantum dots is

sandwiched between layers of electron-transporting and hole-transporting organic materials. An applied electric field causes electrons and holes to move into the quantum dot layer, where they are captured in the quantum dot and recombine, emitting photons. The spectrum of photon emission is narrow, characterized by its full width at half the maximum value.

51.1. QLEDS ADVANTAGES

- **Pure color** – Will deliver 30-40% luminance efficiency advantage over organic light emitting diodes (OLEDs) at the same color point.
- **Low power consumption** – QLEDS have the potential to be more than twice as power efficient as OLEDs at the same color purity.
- **Low-cost manufacture** – The ability to print large-area QLEDS on ultra-thin flexible substrates will reduce luminaire manufacturing cost.
- **Ultrathin, transparent, flexible form factors** – QLEDS will enable designers to develop new display and lighting forms not possible with existing technologies.

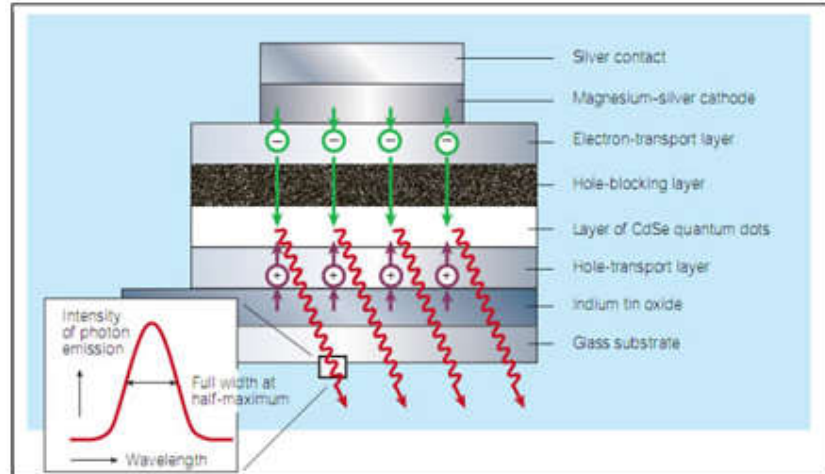

51.2. DISADVANTAGES

- Quantum dots from most suppliers also contain cadmium, a toxic metal whose use is restricted in many countries.

52. HEAD TRANSPLANT

Why in News:

Chinese and Italian transplant specialists are planning to conduct the world's first human head transplant surgery

- A head transplant is a surgical operation involving the grafting of an organism's head onto the body of another.
- It should not be confused with another, hypothetical, surgical operation, the brain transplant.
- Head transplantation involves decapitating the patient. Although it has been successfully performed using dogs, monkeys and rats, no human is known to have undergone the procedure. Recently
- This technique has been proposed as possibly useful for people who are already quadriplegics and who are also suffering from widespread organ failures which would otherwise require many different and difficult transplant surgeries. Quadriplegia may be an acceptable option for the terminally ill.
- There is no uniform consensus on the ethics of such a procedure.

53. HIBERNATION

- Hibernation is a state of inactivity and metabolic depression in animals, characterized by lower body temperature, slower breathing, and/or lower metabolic rate. Hibernating animals conserve energy, especially during winter when food supplies are limited, tapping energy reserves, body fat, at a slow rate. Hibernation during summer months is known as aestivation.

- Although often associated with cold temperatures, the root purpose of hibernation is to conserve food during a period when sufficient food is scarce. It is the animal's slowed metabolic rate which leads to a reduction in body temperature and not the other way around. Hibernation may last several days, weeks, or months depending on the species, ambient temperature, time of year, individual animal's body condition, and fur on the animal's body.
- Before entering hibernation, most species eat a large amount of food and store energy in fat deposits to survive the winter. Some species of mammals hibernate while gestating young, which are either born while the mother hibernates or shortly afterwards.

54. TISSUE ENGINEERING

- Tissue engineering is the use of a combination of cells, engineering and materials methods, and suitable biochemical and physio-chemical factors to improve or replace biological functions.
- While most definitions of tissue engineering cover a broad range of applications, in practice the term is closely associated with applications that repair or replace portions of or whole tissues (i.e., bone, cartilage, blood vessels, bladder, skin, muscle etc.). Often, the tissues involved require certain mechanical and structural properties for proper functioning. The term has also been applied to efforts to perform specific biochemical functions using cells within an artificially-created support system (e.g. an artificial pancreas, or a bio artificial liver).
- Tissue Engineering is a multidisciplinary field that applies the principles of Biology, Chemistry, Physics and Engineering for the development of substitutes that replace, repair or enhance biological function of diseased and damaged human body parts, by manipulating cells via their extracellular microenvironment. This three dimensional extracellular architecture ("scaffold") can be fabricated in the shape of the tissue we want to restore.

55. CRYOPROTECTANT

- A cryoprotectant is a substance that is used to protect biological tissue from freezing damage (i.e. that due to ice formation). Arctic and Antarctic insects, fish and amphibians create cryoprotectants (antifreeze compounds and antifreeze proteins) in their bodies to minimize freezing damage during cold winter periods. Insects most often use sugars or polyols as cryoprotectants. Arctic frogs use glucose, but Arctic salamanders create glycerol in their livers for use as a cryoprotectant. Cryoprotectants operate simply by increasing the solute concentration in cells. However, in order to be biologically viable they must (1) easily penetrate cells, and (2) not be toxic to the cell.
- Conventional cryoprotectants are glycols (alcohols containing at least two hydroxyl groups), such as ethylene glycol propylene glycol, and glycerol. Ethylene glycol is commonly used as automobile antifreeze, and propylene glycol has been used to reduce ice formation in ice cream. Dimethyl sulfoxide (DMSO) is also regarded as a conventional cryoprotectant. Glycerol and DMSO have been used for decades by cryobiologists to reduce ice formation in sperm and embryos that are cold-preserved in liquid nitrogen.

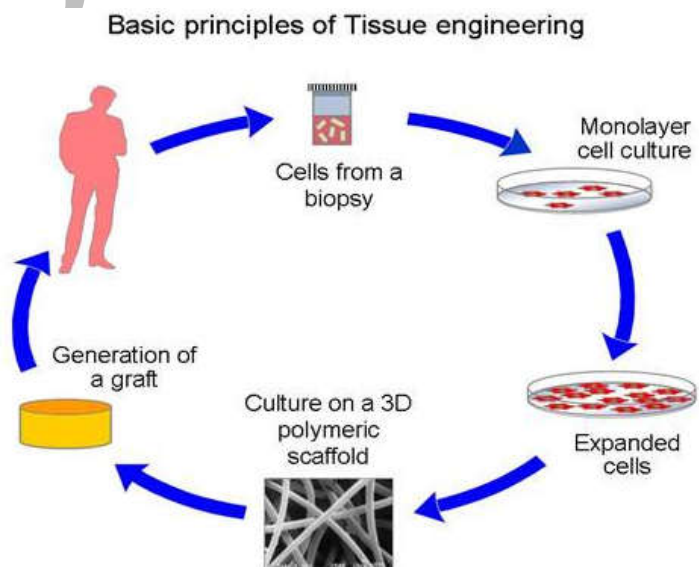

56. MEMRISTOR

- It is the long theorized basic circuit element that can generate voltage from a current (like a resistor), but in a more complex, dynamic manner -- with the ability to "remember" previous current.

A memristor never forgets

©NewScientist

The "resistor with memory" that Leon Chua described behaves like a pipe whose diameter varies according to the amount and direction of the current passing through it

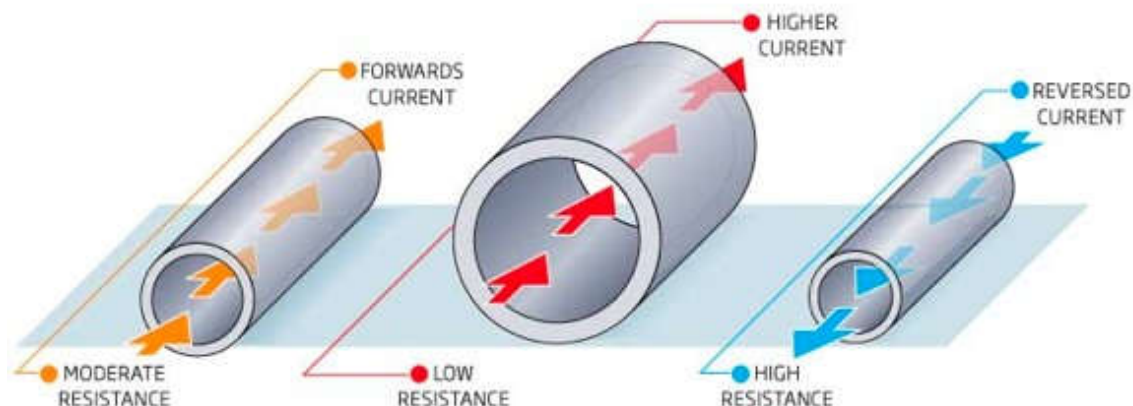

● IF THE CURRENT IS TURNED OFF, THE PIPE'S DIAMETER STAYS THE SAME UNTIL IT IS SWITCHED ON AGAIN - IT "REMEMBERS" WHAT CURRENT HAS FLOWED THROUGH IT

- Memristors are basically a fourth class of electrical circuit, joining the resistor, the capacitor, and the inductor, that exhibit their unique properties primarily at the nanoscale. Theoretically, Memristors, a concatenation of "memory resistors", are a type of passive circuit elements that maintain a relationship between the time integrals of current and voltage across a two terminal element. Thus, a memristors resistance varies according to a devices memristance function, allowing, via tiny read charges, access to a "history" of applied voltage.
- The memristor was originally envisioned in 1971 by circuit theorist Leon Chua as a missing non-linear passive two-terminal electrical component relating electric charge and magnetic flux linkage.
- In March 2012, a team of researchers from HRL Laboratories and the University of Michigan announced the first functioning memristor array built on a CMOS chip for applications in neuromorphic computer architectures.

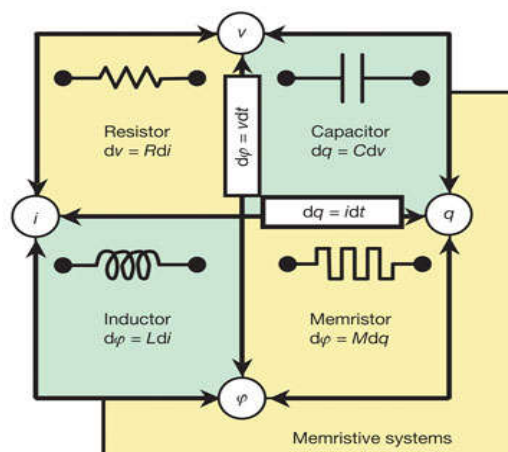

57. ELECTRONIC NOSE

- An electronic nose (e-nose) is a device that identifies the specific components of an odor and analyses its chemical makeup to identify it. An electronic nose consists of a mechanism for chemical detection, such as an array of electronic sensors, and a mechanism for pattern recognition, such as a neural network. Electronic noses have been around for several years but have typically been large and expensive. Current research is focused on making the devices smaller, less expensive, and more sensitive. The smallest version, a nose-on-a-chip is a single computer chip containing both the sensors and the processing components.

- Electronic Noses include three major parts: a sample delivery system, a detection system, a computing system.
- To perform analysis, an electronic nose need to be trained with qualified samples so as to build a database of reference. Then the instrument can recognize new samples by comparing volatile compounds fingerprint to those contained in its database. Thus they can perform qualitative or quantitative analysis.

57.1. RECENT ADVANCES

- Detection of perineal odours associated with oestrus in cows.
- Detection of lung cancer in humans.
- NASA uses enose for detecting ammonia leakage in spacecraft.

58. OPTICAL COMPUTING

- An optical computer (also called a photonic computer) is a device that uses the photons in visible light or infrared (IR) beams, rather than electric current, to perform digital computations. An electric current flows at only about 10 per cent of the speed of light. This limits the rate at which data can be exchanged over long distances, and is one of the factors that led to the evolution of optical fibre. By applying some of the advantages of visible and/or IR networks at the device and component scale, a computer might someday be developed that can perform operations 10 or more times faster than a conventional electronic computer.
- Optical technology has made its most significant inroads in digital communications, where fibre optic data transmission has become commonplace. The ultimate goal is the so-called photonic network, which uses visible and IR energy exclusively between each source and destination. Optical technology is employed in CD-ROM drives and their relatives, laser printers, and most photocopiers and scanners. However, none of these devices are fully optical; all rely to some extent on conventional electronic circuits and components.

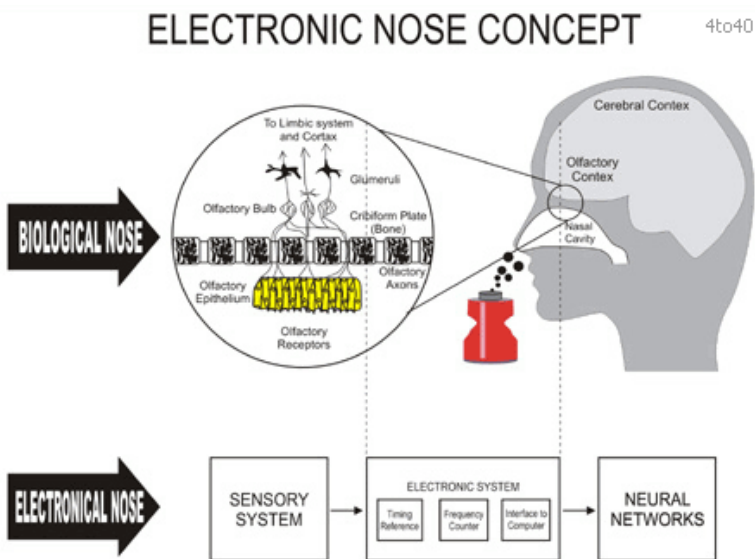

59. QUANTUM DOT

- Quantum dots are tiny particles, or “nanoparticles”, of a semiconductor material, traditionally chalcogenides (selenides or sulfides) of metals like cadmium or zinc (CdSe or ZnS, for example), which range from 2 to 10 nanometers in diameter (about the width of 50 atoms).
- Because of their small size, quantum dots display unique optical and electrical properties that are different in character to those of the corresponding bulk material. The most immediately apparent of these is the emission of photons under excitation, which are visible to the human eye as light. Moreover, the wavelength of these photon emissions depends not on the material from which the quantum dot is made, but its size.
- The ability to precisely control the size of a quantum dot enables the manufacturer to determine the wavelength of the emission, which in turn determines the colour of light the human eye perceives. Quantum dots can therefore be “tuned” during production to emit any colour of light desired. The ability to control, or “tune” the emission from the quantum dot by changing its core size is called the “size quantisation effect”.
- The smaller the dot, the closer it is to the blue end of the spectrum, and the larger the dot, the closer to the red end. Dots can even be tuned beyond visible light, into the infra-red or into the ultra-violet.

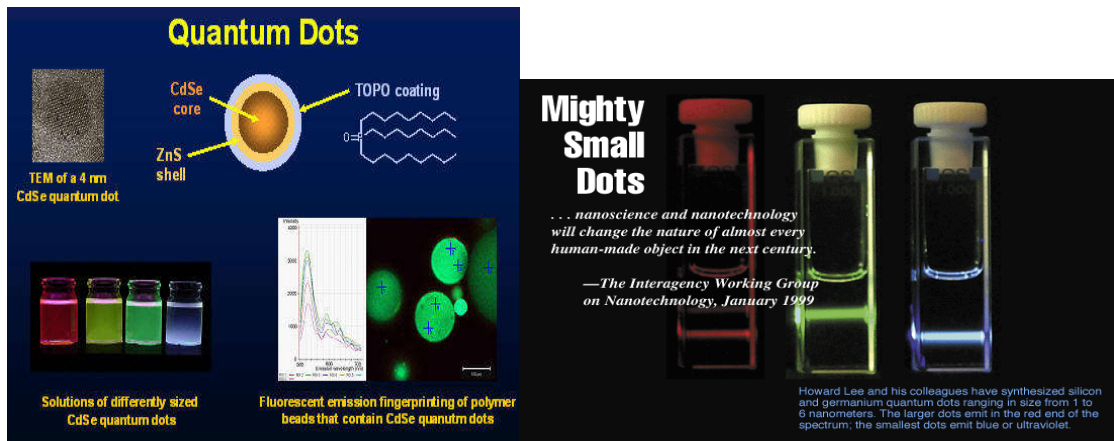

- Quantum dots are particularly significant for optical applications due to their high extinction co-efficient. In electronic applications they have been proven to operate like a single electron transistor and show the Coulomb blockade effect. Quantum dots have also been suggested as implementations of qubits for quantum information processing.
- The ability to tune the size of quantum dots is advantageous for many applications. For instance, larger quantum dots have a greater spectrum-shift towards red compared to smaller dots, and exhibit less pronounced quantum properties. Conversely, the smaller particles allow one to take advantage of subtler quantum effects.

60. MOLECULAR NANOTECHNOLOGY

- Molecular nanotechnology (MNT) is a technology based on the ability to build structures to complex, atomic specifications by means of mechanosynthesis. This is distinct from nanoscale materials.
- MNT would involve combining physical principles demonstrated by chemistry, other nanotechnologies, and the molecular machinery of life with the systems engineering principles found in modern macroscale factories.
- It is an anticipated manufacturing technology that would allow precise control and positional assembly of molecule-sized building blocks through the use of nano-scale manipulator arms. Molecular nanotechnology is usually considered distinct from the more inclusive term "nanotechnology", which is now used to refer to a wide range of scientific or technological projects that focus on phenomena or properties of the nanometer scale (around 0.1-100nm). Nanotechnology is already a blossoming field, but molecular nanotechnology — the goal of productive, molecular-scale machine systems — is still in the preliminary research stage.
- Its projected applications are- Smart materials and nanosensors, Replicating nanorobots, Medical nanorobots, Utility frog, Phased array optics.
- Molecular nanotechnology will let us continue the historical trends in manufacturing right up to the fundamental limits imposed by physical law. It will let us make remarkably powerful molecular computers. It will let us make materials over fifty times lighter than steel or aluminium alloy but with the same strength. We'll be able to make jets, rockets, cars or even chairs that, by today's standards, would be remarkably light, strong, and inexpensive. Molecular surgical tools, guided by molecular computers and injected into the blood stream could find and destroy cancer cells or invading bacteria, unclog arteries, or provide oxygen when the circulation is impaired.

61. INDUCED PLURIPOTENT STEM CELLS (IPSC)

- iPSCs are body (somatic) cells which have been reprogrammed to function like embryonic stem cells, thereby sidestepping the controversial use of killing the embryos while harvesting the stem cells.
- This is done by introducing four regulatory factors (pieces of DNA) into the cells.
- Scientists at the Guangzhou Institutes of Biomedicine and Health, China have claimed that they have improved the efficiency of Shinya Yamanaka's invention of producing induced Pluripotent Stem Cells (iPSC) which won Nobel Prize in Medicine.

62. NEXT GENERATION ROBOTICS

- Next Generation Robotics will be more like "human" and will have capabilities and traits such as **sensing, dexterity, memory, trainability, and object recognition**.
- Robotics is evolving away from the large, complex, and expensive industrial robotics toward inexpensive, smaller, and **safer people-friendly systems**. This new generation of robots will not only look more human, but will be taking on human tasks, both in the workplace and even in the home.
- Cloud-computing revolution will able them to access instructions and information remotely, rather than having to be programmed as a fully autonomous unit.
- The emergence of this next generation of robots is made possible by the many advances in a variety of enabling technologies. These include the increasing amount of **computing power and sensor technology** available for a given price.

62.1. DIFFERENT LAYERS OF INTELLIGENCE IN ROBOTS:

There are 3 layers of Intelligence.

- **Action intelligence** functions are analogous to nervous system responses that coordinate sensory and behavioural information, thereby giving a robot the ability to control head and eye movement, move spatially, operate machine arms to manipulate objects, and visually inspect its immediate environment
- **Autonomous intelligence** refers to capabilities for solving problems involving pattern recognition, automated scheduling, and planning based on prior experience. Such behaviours are logical and programmable, but not conscious.
- **Human-Based Intelligence** - higher cognitive abilities that allow for new ways of looking at one's environment and for abstract thought, also referred to as "mind" and "real intelligence".

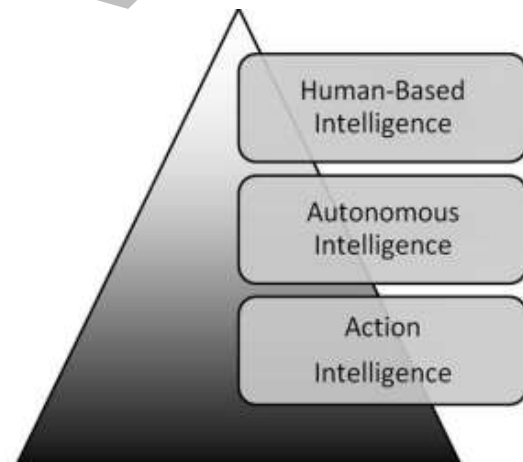

Robot Intelligence Layers

Currently action intelligence and autonomous intelligence are in developmental stage. Next Generation Robotics will incorporate Human Based Intelligence.

62.2. APPLICATIONS

- Increase the productivity of workers in the manufacturing sector;
- Assist astronauts in dangerous and expensive missions;
- Help scientists accelerate the discovery of new, life-saving drugs,
- Improve food safety by rapidly sensing microbial contamination,

- Also in logistics, services, transportation, security, defence, medicine, healthcare, space exploration, environmental monitoring, and agriculture;
- Robotics can play an important role in science, technology, engineering and mathematics (STEM) education because it encourages hands-on learning and the integration of science, engineering, and creative thinking.

62.3. APPREHENSION:

- There remains the risk that robots may displace human workers from jobs
- Decades-old fears of networked robots running out of control may become more salient with next generation robotics linked into the web.
- Unlike heavily regulated industrial robots that toil in isolated settings, Next Generation Robots will have relative autonomy, which may raise a number of safety issues.

63. METAMATERIALS

- “Meta-material” refers to any material that gains its properties from structure rather than composition.
- Meta-materials have been used to create microwave invisibility cloaks, 2D invisibility cloaks, and materials with other unusual optical properties.
- Mother-of-pearl gets its rainbow color from meta-materials of biological origin.
- Some meta-materials have a negative refractive index, an optical property that may be used to create “Super-lenses” which resolve features smaller than the wavelength of light used to image them! This technology is called sub-wavelength imaging.
- Thus, Meta-materials are artificial materials engineered to have properties that may not be found in nature. Meta-materials usually gain their properties from structure rather than composition, using small inhomogeneities to create effective macroscopic behavior.
- Negative refractive index of the meta-materials appear to permit the creation of super-lenses which can have a spatial resolution below that of the wavelength.
- Potential applications of meta-materials are diverse and include remote aerospace applications, sensor detection and infrastructure monitoring, smart solar power management, public safety, radomes, high-frequency battlefield communication and lenses for high-gain antennas, improving ultrasonic sensors, and even shielding structures from earthquakes.
- The research in metamaterials is interdisciplinary and involves such fields as electrical engineering, electromagnetics, solid state physics, microwave and antennae engineering, optoelectronics, classic optics, material sciences, semiconductor engineering, nanoscience and others.



64. BIO-DIGESTER

- A biodigester is an anaerobic tank (oxygen-free), which digests organic material biologically.
- It is used to treat black water (human waste) on site, eliminating pathogens and malignant bacteria, so the treated water can be used for irrigation.

64.1. BENEFITS OF USING A BIODIGESTER:

- It digests organic solids in an ecological way;
- It prevents human waste and untreated water from contaminating groundwater;
- It offers an alternative to dumping sewage into rivers, lakes and fields in rural and semi-rural areas where there are no city sewage systems;
- The effluent of water can be used as fertilizer for soil, to water plants, or for fish ponds;
- It's cleaner, more effective and easier to use than a septic tank because it doesn't need to be cleaned or emptied and doesn't create leakage problems;
- It is odorless, as opposed to composting toilets and septic tanks;
- It doesn't require the work and energy involved in relocating composting toilets every year.

SECTION B: CURRENT AFFAIRS (JANUARY TO SEPTEMBER)

1. TOPIC: SCIENCE AND TECHNOLOGY DEVELOPMENTS

1.1. NOBEL PRIZE IN PHYSICS 2015

- To Takaaki Kajita from Japan and Arthur B. McDonald from Canada, for their key contributions to the experiments which demonstrated that **neutrinos change identities**.

Why this discovery is important?

- Compared to theoretical calculations of the number of neutrinos from sun, only one third was detected in measurements performed on Earth.
- Their separate experiments discovered that the neutrinos during their travel change their identity which is called neutrino oscillations or metamorphosis.
- However, **for this to happen they must have mass**; however, the standard model, a theory to explain particle physics, had earlier predicted Neutrinos to be massless.
- Thus this discovery also showed that our understanding of sub atomic particles is not complete and standard model needs correction.

Neutrino:

Neutrinos are one of the fundamental particles which make up the universe. Neutrinos are similar to the electron, with one crucial difference: neutrinos do not carry electric charge.

- Tiny electrically neutral particles
- cannot be broken into further smaller pieces
- Charge less and are almost massless
- Second most abundant particle in the universe after photon
- Neutrinos occur in three different types, or flavours –
 - electron-neutrinos (ν_e),
 - muon-neutrinos (ν_μ)
 - tau-neutrinos (ν_τ).
- These are separated in terms of different masses. Some were created already in the Big Bang; others are constantly being created in various processes in space and on Earth

1.1.1. INDIA-BASED NEUTRINO OBSERVATORY (INO)

The India-based Neutrino Observatory (INO) Project is a multi-institutional effort aimed at building a world-class underground laboratory with a rock cover of approx.1200 m for non-accelerator based high energy and nuclear physics research in India.

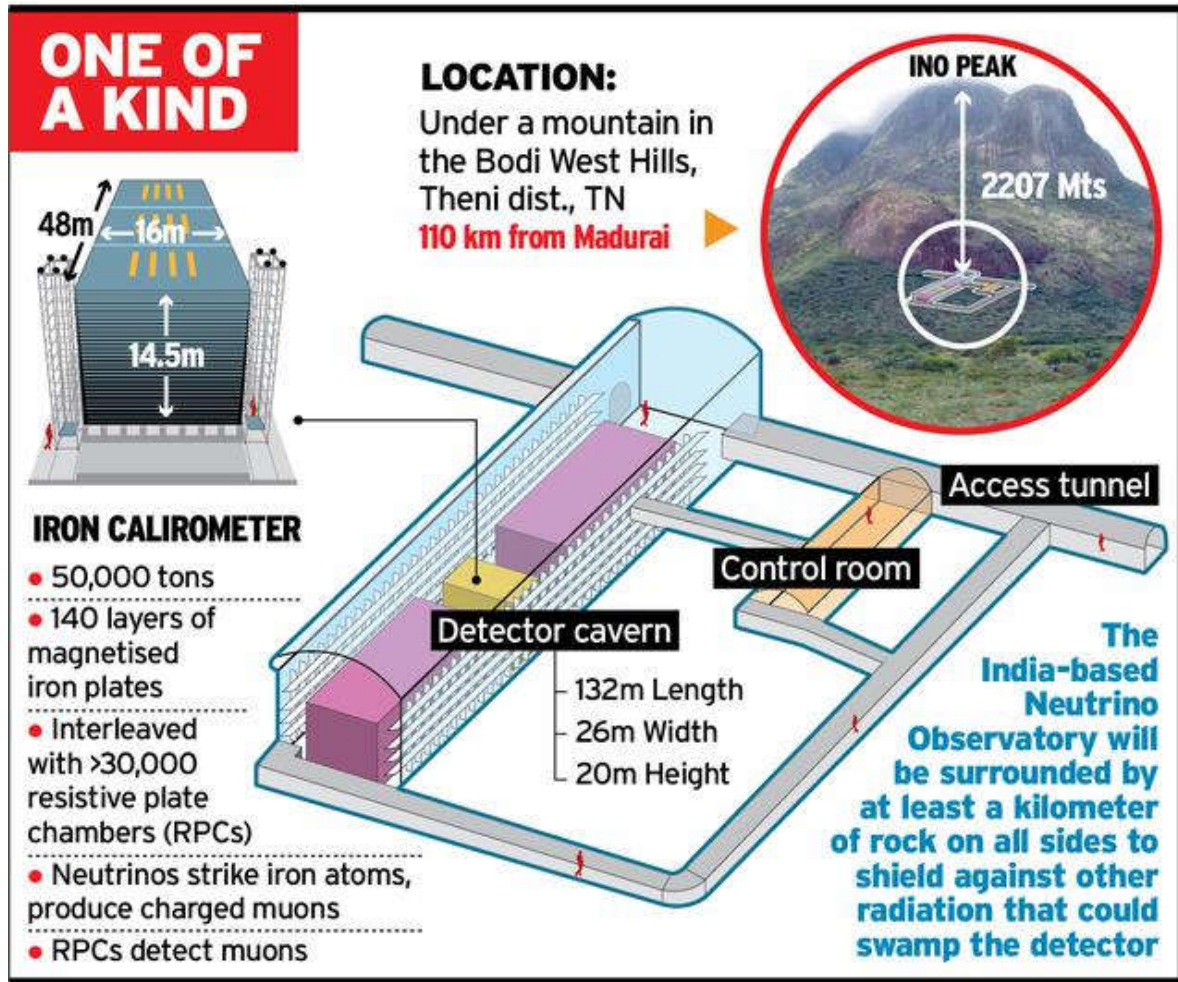

INFOGRAPHIC: PRATHAP RAVISHANKAR

The INO is set to come up on the hills near Thevaram in Theni district and will have a 50,000-tonne magnetic detector to study neutrinos that are significant in particle physics.

In the 1960s, a neutrino observatory located at the Kolar Gold Fields in Karnataka became one of the world's first experiments to observe neutrinos in the Earth's atmosphere, produced as a by-product of cosmic rays colliding with its upper strata. However, the laboratory was shut in the 1990s because the mines were being closed.

Objective: Determination of neutrino masses is the most significant open problem in particle physics today and is the key goal of the INO project.

Benefits:

- According to government INO will be the agent of transforming physics of this kind in India and will make a global impact. The outcome of this investment will be extraordinary and long term.
- Understanding the particle will help scientists pick the correct theory beyond the standard model of particle physics and address the problem of matter-antimatter asymmetry of the universe.
- Research on neutrino particle would be path breaking in the field of science and will help in knowing more about the universe.
- An important outcome of the project will be training young researchers in large-scale experimental science.
 - It can play a role in nuclear non-proliferation through the remote monitoring of nuclear reactors. Using Neutrino detectors, the plutonium content can be monitored remotely and can be used to detect any pilferage.
 - Study of **Geoneutrinos** might help creating an earthquake warning system. This field of science is called Neutrino Tomography.

1.2. NOBEL PRIZE IN CHEMISTRY

To Paul Modrich , Aziz Sancar and Thomas Lindahl - For explaining the **DNA repair mechanism**.

Contribution:

- Paul Modrich demonstrated "Mismatch repair System". This mismatch system contains a number of important protein, who can recognise the mismatch and also recognise the newly synthesised strands then create new synthesis and take away the piece of DNA containing mismatch the DNA synthesised the correct strand.
- Aziz Sancar Investigated "UV induced damage" in DNA. He has identified the components and characteristics and their mechanism know as "Nucleotide excision repair".
- Thomas Lindahl demonstrated that DNA decays at a rate that ought to have made the development of life on earth impossible. This insight led him to discover molecular machinery "Base Excision Repair" which constantly counteracts the collapse of our DNA.

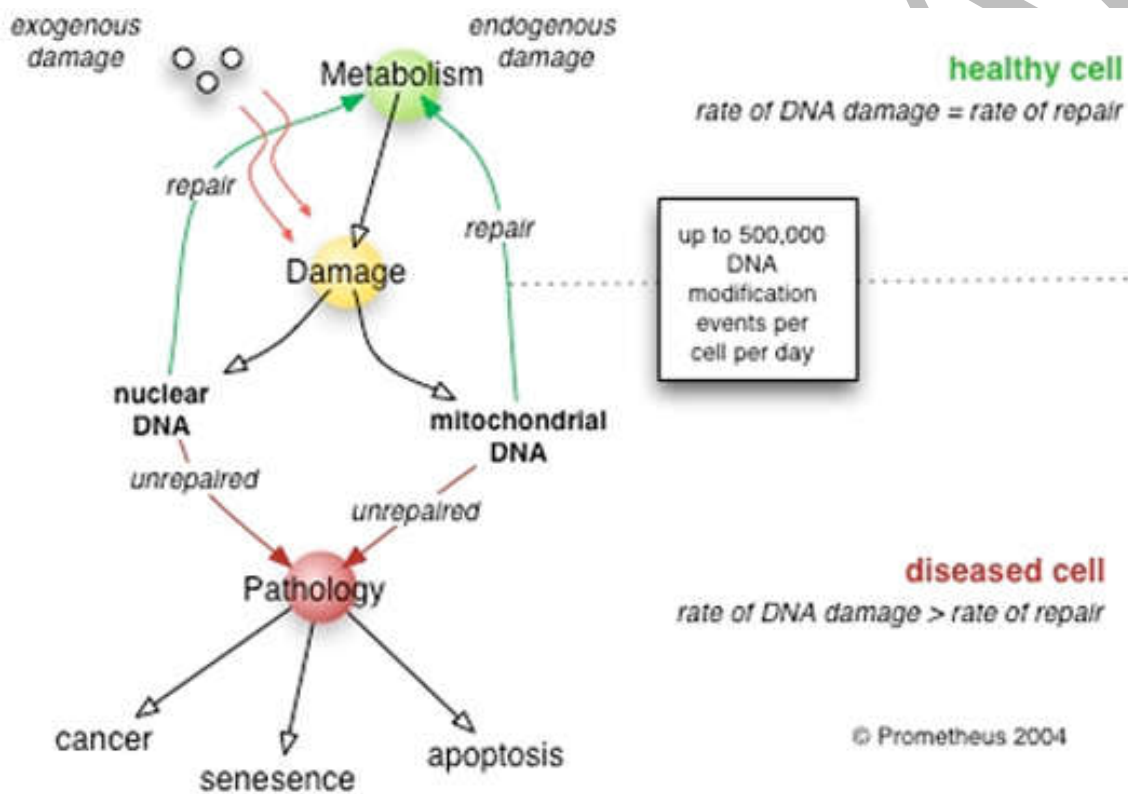

Significance:

- Nobel laureates explained basic cell mechanism at molecular level that helps to guide us on the integrity of our DNA system.
- Their systematic work has made a decisive contribution to the understanding of how the living cell functions, as well as providing knowledge about the molecular causes of several hereditary diseases and about mechanisms behind both cancer development and ageing.

What Next

- In many forms of cancer, one or more of these repair systems have been entirely or partially switched off. This makes the cancer cells DNA unstable, which is one reason why cancer cells often mutate and become resistant to chemotherapy.

- At the same time, these sick cells are even more dependent on the repair systems that are still functioning; without these, their DNA will become too damaged and the cells will die.
- Researchers are attempting to utilise this weakness in the development of new cancer drugs. Inhibiting a remaining repair system allows them to slow down or completely stop the growth of the cancer.

1.3. NOBEL PRIZE IN MEDICINE

- To- Satoshi Ōmura, William C. Campbell and Youyou Tu.
- For exceptional effective treatment against parasitic disease: malaria and Elephentitis.

Contributions:

- Campbell and Ōmura won for their discoveries concerning a novel therapy against infections caused by roundworm parasites.
- Shared the prize with Youyou Tu for her work on a therapy against malaria. Tu discovered one of the most effective treatments for malaria while working on a secret military project during China's Cultural Revolution.

Importance of new therapies:

- Parasitic diseases have affected hundreds of millions of most vulnerable section of the world. Elephentitis is stigmatising and disabling disease of Lymphatic system that causes lifelong problem in Leg and Scrotal Hydrocele.
- River Blindness (Onchocerciasis) leads to blindness, because of chronic inflammation in the cornea. These Parasites are transmitted by a Mosquito to Humans in the body. The life cycle of the parasite is maintained by bringing human being and transmitting parasite to new person.
- Malaria is caused by parasite transmitted by mosquito to human. Malaria was treated by chloroquine or quinine, but with declining success. By the late 1960s, efforts to eradicate Malaria had failed and the disease was on the rise.
- Treatment with Livermartin is so successful that Elephentitis and River Blindness are on the Verge of Eradication but the Impact of Livermatrin and Artemisiin are far beyond the reducing the disease burden of Individuals by allowing Children to go to school, adult to go to work. Global impact of their discovery and resulting benefit to mankind is immeasurable.

Lessons for India: Traditional knowledge system:

- India needs to connect the missing dots in terms of its rich heritage of traditional system of medicine to fight from emerging diseases. In this context the National AYUSH mission becomes very important:

Objectives:

- To upgrade the educational standards in Indian System of Medicines and Homeopathy college in the country.
- To strengthen existing research institution and ensure a time-bound research programme on identified diseases for which these systems have an effective treatment.
- To draw up schemes for promotions, cultivations and regeneration of medicinal plants used in these system.
- To evolve Pharmacopoeial standards for Indian System of Medicine and Homeopathy drugs.

1.4. INDIA ASSOCIATE MEMBER IN CERN

The Centre has approved that the country be an associate member of CERN (European Organisation for Nuclear Research). **CERN** is the world's biggest laboratory of particle physics and operates the Large Hadron Collider (LHC).

Currently, India has observer status in CERN, which has 21 member states.

Significance of being associate member:

- It Will boost its **science credentials**
- Indian manufacturing firms **gain greater clout** in pitching for CERN construction contracts.
- access to spin offs and intellectual property
- more opportunities for Indian institutions and companies to participate in future projects
- more possibilities for Indian scientists to engage with their counterparts in front line research, and greater institutional and academic collaboration involving physics and engineering
- As associate member, India will have the right to attend and **participate in both the open and restricted sessions of the CERN Council** as also send representatives to the meetings of the organization's Finance Committee Indians will also be eligible for appointments as staff members at CERN on contracts of limited duration and as Fellows.

1.5. GRAVITATIONAL WAVES

- As early as 1916, Einstein predicted gravitational waves as a consequence of his general theory of relativity.
- Gravitational waves are ripples in the fabric of space-time produced by violent events such as the collision of two black holes or by cores of supernova explosions.
- They are produced by accelerating masses, just the same as accelerating charged particles produce radio waves (e.g. electrons in antennas).
- Among other things, studying gravitational waves can tell us more about the nature of gravity.
- In fact, the waves have not been directly detected so far, but indirect evidence that they exist comes from 1974 discovery of the Hulse-Taylor binary pulsar whose period of orbit decreases in a manner exactly predicted by general theory of relativity.
- This system is believed to emit gravitational waves, in accordance with what Einstein had predicted would happen to masses moving relatively to each other.
- Russell Hulse and Joseph Taylor were awarded the Nobel Prize for this discovery in 1993.

1.5.1. LIGO (LASER INTERFEROMETER GRAVITATIONAL-WAVE OBSERVATORY)

- LIGO is a large-scale physics experiment aiming to directly detect gravitational waves.
- This detector recently underwent upgradation which would make it ten times more sensitive, which, in turn, would provide a 1000-fold increase in the number of astrophysical candidates for gravitational wave signals.

1.6. LARGE HADRON COLLIDER RESTARTS EXPERIMENTS AFTER TWO-YEAR UPGRADE

- CERN, the European Organisation for Nuclear Research, reported that particle beams were successfully pushed around the LHC in both directions after a two-year shutdown.
- During the first run of the LHC, the ATLAS and CMS experiments announced the discovery of the so-called Higgs boson.
- The huge collider, **which has undergone more than two years of upgrades**, to give it double the power, will now run non-stop for the next three years.

Benefits of extra energy:

- May reveal particles that have never been seen before.
- Will help in getting more information about dark matter.
- Researchers will look for evidence of “new physics” and probe “supersymmetry” — a theoretical concept informally dubbed **Susy**; seek explanations for enigmatic dark matter and look for signs of extra dimensions.

1.6.1. WHAT IS DARK MATTER?

- **Dark matter** is a hypothetical kind of **matter** that cannot be seen with telescopes but would account for most of the **matter** in the universe. The existence and properties of **dark matter** are inferred from its gravitational effects on visible **matter**, radiation, and the large-scale structure of the universe.
- Dark energy plus dark matter constitutes 95.1% of the total mass–energy content of the universe
- Dark matter cannot be seen but its huge impact can be viewed through telescopes because it bends light around galaxies creating a ring of star light known as gravitational lensing.

1.7. PARTHENOGENESIS/ VIRGIN BIRTH

It is the first time this phenomenon has been seen in a vertebrate in the wild. There have been a number of cases in reptiles, birds and sharks of ‘virgin birth’ in captivity.

- It is reproduction without mating.
- **Process:**
 - In this a female’s egg cell can develop into a baby without being fertilized by a male’s sperm cell.
 - In making an egg cell, a precursor cell divides into four cells.
 - The one that eventually becomes the egg cell retains key cellular structures and the gel-like cytoplasm.
 - The other three hold extra genetic material. One of these cells essentially acts as a sperm cell and fuses with the egg.
 - This “fertilized” egg possesses about half the mother’s genetic diversity, a trait allowing parthenogenesis to be detected through genetic testing.

Why in News: Scientists have documented in Florida a series of “virgin births,” reproduction without mating, in a **critically endangered** sawfish species pushed to the brink of extinction by over-fishing and habitat destruction. It marks the first time the phenomenon called parthenogenesis has been seen in a vertebrate in the wild.

Reason of Virgin Birth in Smalltooth Sawfish: Smalltooth sawfish numbers are so low that mating opportunities may not exist.

1.8. POWERWALL

- The Powerwall is a rechargeable lithium-ion battery product manufactured by Tesla Motors for home use.
- It charges home appliances using electricity generated from solar panels when sun goes down.
- Automated, compact and simple to install, Powerwall offers independence from the utility grid and the security of an emergency backup.
- The **Powerpack** is a bigger variant available for industrial consumers with a storage capacity of 100 kWh.

Prime Minister’s visit to Tesla Motors was primarily due to India’s interest in the company’s solar Powerwall technology.

2. TOPIC: INDIGENIZATION OF TECHNOLOGY

2.1. IRIDS

IRIDS (Intelligent Red Light Violation Identification System), developed by the Centre for Development of Advanced Computing (C-DAC), is a state-of-the-art device that captures images and videos of red light violations with the help of vehicle sensors, cameras, and controller hardware installed at busy road intersections.

PRAGATI (Pro-Active Governance and Timely Implementation):

This is a platform which aimed at addressing common man's grievances, and simultaneously monitoring and reviewing important programmes and projects of the Government of India as well as projects flagged by State Governments.

Features:

- Multi-purpose and multi-modal platform
- Unique integrating and interactive platform
- This platform will fulfil three objectives -: Grievance Redressal, Programme Implementation and Project Monitoring. This is an IT-based redressal and monitoring system.
- It uniquely bundles three latest technologies: Digital data management, video-conferencing and geo-spatial technology.
- With this, the Prime Minister is able to discuss the issues with the concerned Central and State officials with full information and latest visuals of the ground level situation.

Significance:

- It will make government more efficient and responsive.
- It is a step in the direction of cooperative federalism since it brings on one stage the Secretaries of Government of India and the Chief Secretaries of the States.
- It is also an innovative project in e-governance and good governance.

2.2. DIGILOCKER

DigiLocker, the digital locker system launched by the government to securely store documents online, has received good response since its beta launch last month. The locker can be accessed by individuals, using their number.

Features:

- It is a dedicated personal storage space, linked to each resident's Aadhaar number.
- DigiLocker can be used to securely store e-documents as well as store Uniform Resource Identifier (URI) link of e-documents issued by various issuer departments.
- It has an e-Sign facility which is provided as part of DigiLocker system can be used to digitally sign e-documents.
- The users can store their documents such as insurance, medical reports, PAN card, passport, marriage certificate, school certificate and other documents in the digital format.

HOW DOES DIGILOCKER WORK?

➤ TO Sign-up for the Digilocker you need to have an Aadhaar and **mobile number registered with Aadhaar.**

➤ Type your Aadhaar number and the **captcha code.**

➤ After clicking signup

button, an OTP (**One Time Password**) will be sent to the registered mobile number and email-id.

➤ Enter OTP and click on "Validate OTP" **button to complete the sign up and login.**

- 10MB of free space in the locker to securely store resident documents and store links (URI) of Govt. department or agency issued e-documents. The storage space allocation will be increased to 1GB in subsequent release.

Advantages:

- It will minimize the use of physical documents and will provide authenticity of the e-documents.
- It will provide secured access to Govt. issued documents.
- It will also reduce administrative overhead of Govt. departments and agencies and make it easy for the residents to receive services.

Why in news: It has received good response since its launch by the Department of Electronics and Information Technology, under the Ministry of Communications and IT last month.

2.3. STEPS TAKEN BY RAILWAY TO IMPROVE SERVICE DELIVERY

2.3.1. KAYA KALP COUNCIL

- The Minister of Railways has now constituted the 'Kayakulp' Council and has appointed ShriRatan Tata to head this Council.
- **Purpose:** It is an innovation council called Kaya kalp. Its purpose is to recommend innovative methods and processes for the improvement, betterment and transformation of the Indian Railways.

2.3.2. LAUNCHED RUPAY PRE-PAID DEBIT CARD

- ✓ The service was launched by the IRCTC in collaboration with Union Bank of India and the National Payment Corporation of India (NCPI).
- ✓ Availability: UBI offices or through IRCTC online. One does not need to have a bank account in UBI to have the card and you can avail it online also.

Use of RuPay pre-paid debit card:

- Customer can book tickets, do shopping and pay service bills using RuPay pre-paid cards.
- Card holder will get free Rs.1 lakh accident insurance coverage as part of the benefits to customers.
- Under this both virtual as well as physical cards are being issued to customers in two variants.

What is RuPay: RuPay is India's own **card payment gateway network** like Visa and Master Card, and provides an alternative system for banks to provide a debit card service.

- Earlier this month, IRCTC tied with Amazon.in to sell various products to IRCTC customers.
- IRCTC tied up with Jubilant Food works to deliver Dominos' pizza to the passenger's seat if they were traveling across selected stations in India.
- IRCTC had also tied-up with BookMyTrain.com to introduce cash on delivery (CoD) payment mode for buying train tickets.
- Earlier, NPCI had mentioned that users could book train tickets on IRCTC using the RuPay debit card.

National Electoral Roll Purification and Authentication Programme (NERPAP):

National Electoral Roll Purification and Authentication Programme (NERPAP) is voter registration project of the Election Commission of India. It will link the Elector's Photo Identity Card (EPIC) with the Aadhar number of the registered voter.

Objective:

- A totally **error free and authenticated** electoral roll.
- The project expects to remove duplicate, fake and ineligible voters, and voters who have shifted to other regions from the databases.

What will be done in this programme:

- EPIC data of electors will be linked with Aadhar data of UIDAI for the purpose of authentication.
- The voters can submit their Aadhar and EPIC number by SMS, email, mobile application and website.
- Improving image quality of electors along with sorting issues like corrections of errors etc.
- To collect data regarding EPIC and Aadhar Card various provisions are made such as
 - ✓ Organizing Special Camp, Voter Facilitation Centres, e-Sevacentres and Citizen Service Centres
 - ✓ Booth Level Officers (BLOs) will also collect the details of electors during door to door survey.
 - ✓ To ensure maximum public participation, nationwide special camps will be organized by the Electoral Registration Officer in April 2015.

Facility has also been provided for voluntarily Disclosure of Multiple Entries.

2.4. THE INDIAN NAVAL INDIGENISATION PLAN 2015-2030

- This plan aimed at enabling the development of equipment and systems through the Defence Research and Development Organisation (DRDO) and Indian industry over a 15-year period.
- According to the plan, Navy will achieve full indigenisation in all phases of warship construction, from ship-building to systems to weapons.
- The Navy wants to involve private industry in a big way in this initiative.
- **Current status:** A warship can be broadly divided into three segments — float, move and fight. Float category- 90% Indigenisation, move (propulsion) category- 60% Indigenisation, fight (weapons) category- 30% Indigenisation
- There is a huge opportunity for indigenisation of our future naval aviation assets like helicopters.
- The Navy issued its first 15-year indigenisation plan in 2003 and then revised it in 2008. The current revision was done to dovetail it with the 'Make in India' pitch.

GOING LOCAL

Navy aims to achieve full indigenisation in all phases of warship construction from ship-building to weapon making



INDIA'S FIRST INDIGENOUS AIRCRAFT CARRIER INS VIKRANT

- The indigenisation plan 2015-2030 is aimed at enabling **development of equipment and systems** through the DRDO and the Indian industry

- The plan's objective is to have a **200-ship Navy by 2027**

- Navy has achieved 90% indigenisation in the float category; propulsion and weapons components stand at **60% and 30%**

2.5. ATAL INNOVATION MISSION (AIM)

NITI Aayog has constituted an Expert Committee to work out the detailed contours of Atal Innovation Mission (AIM) and Self-Employment & Talent Utilisation (SETU).

Terms of reference of the panel:

- It is set up to review the existing initiatives aimed at promoting innovation and entrepreneurship in India, especially those efforts that result in widespread job growth and the creation of globally competitive enterprises.
- It will make short- and medium-term recommendations for actionable policy initiatives aimed at creating an innovation and entrepreneur friendly ecosystem including such elements as creation of world class innovation hubs and digital SMEs and innovation driven entrepreneurship in such sectors as education and health.
- Besides it will also address any other related issues with innovation and job creation
- The Expert Committee is expected to submit its report in August

What is AIM:

- AIM is an Innovation Promotion Platform in the NITI Aayog, involving academics, entrepreneurs and researchers and draw upon national and international experiences to foster a culture of innovation, R&D and scientific research in India.
- The platform will also promote a network of world-class innovation hubs and grand challenges for India.
- It has an initial fund of 150 crores for R&D announced in this year's budget.
- It will provide funds to a network of institutions to conduct research on innovations that can improve economic growth and job creation.
- The mission will also provide inputs to all central ministries on innovation and suggest a funding mechanism for result-oriented research.
- It has replaced the National Innovation Council, a significant difference between the two will be the powers to disburse funds.

Objectives:

- To create an umbrella structure to oversee innovation ecosystem of the country.
- To provide platform and collaboration opportunities for different stakeholders.
- To study and suggest best and novel practices to be adopted by different stakeholders in the innovation chain.
- To provide policy inputs to NITI Aayog and various government departments and organisations.
- To create awareness and provide knowledge inputs in creating innovation challenges and funding mechanism to govt.
- To develop new programmes and policies for fostering innovation in different sectors of economy.

What is SETU:

- The Government has established a mechanism to be known as SETU (Self-Employment and Talent Utilisation) under NITI Aayog. SETU will be a Techno-Financial, Incubation and Facilitation Programme to support all aspects of start-up businesses, and other self-employment activities, particularly in technology-driven areas.

2.6. AGNI-V

Agni-V is an intercontinental ballistic missile developed by the Defence Research and Development Organisation (DRDO) of India. Agni V is part of the Agni series of missiles, one of the missile systems under the original Integrated Guided Missile

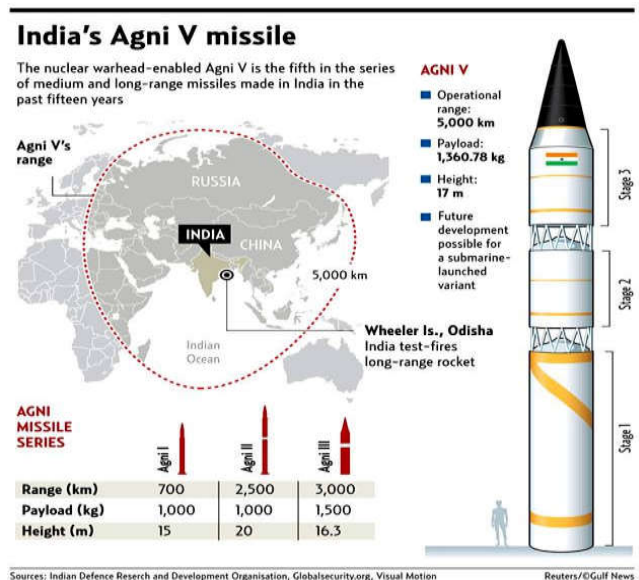

Development Program. The 17-metre-long, three-stage solid-fuelled missile is expected to boost India's nuclear deterrence capability along with other strategic missiles in Agni series. Agni-V is capable of delivering a 1.1 nuclear warhead over a distance of 5,000 km and the range of missile can cover most parts of China and Europe.

Canister-based trial:

The maiden canister-based trial of India's most potent strategic missile, Agni-V was successfully carried out for its full range of more than 5,000 km from the Wheeler Island, off the Odisha. This was the third successful flight test of the Inter- Continental Ballistic Missile and the first canister trial.

2.7. AWACS (AIRBORNE WARNING AND CONTROL SYSTEMS)

- Government approved the development of 2 indigenous Airborne Warning and Control Systems (AWACS) (based on the A-330 aircraft) by the Defence Research and Development Organisation (DRDO).
- Currently, the DRDO is developing two smaller Airborne Early Warning & Control (AEW&C), scheduled to be delivered this year.
- Three AWACS already stand operationalised in the Indian Air Force (IAF).

AWACS USES:

- It is described as an **eye-in-the-sky**.
- It can detect incoming **fighter jets and missiles**.
- It can keep an eye on **troop's movement** across the border.
- It enables military commanders to take **quicker decisions** to counter the enemy's military activities on time.

Difference between AWACS and AEW&C:

- AWACS have **better capabilities** and are mounted on **larger aircraft**, while AEW&C are mounted on smaller planes.

2.8. FLOATING TEST RANGE FOR BALLISTIC MISSILE DEFENCE SYSTEM-BMD PHASE 2

India is building a unique floating testing range — a huge ship with a designated displacement equivalent to 10,000 tonnes. It will overcome the limitations imposed by the land mass for carrying out missile tests of varying ranges for the two-tier ballistic missile defence (BMD) system.

BUILDING A SHIELD

Missile tests will be carried out from a ship in order to overcome limits of land-based ranges



The missile launch pad at Wheeler Island, off the Odisha coast. — FILE PHOTO

MAIN OBJECTIVE

To carry out missile tests for the two-tiered Ballistic Missile Defence (BMD) system that seeks to protect important cities from external threats

WHAT WILL THE BMD DO?

- It seeks to engage and destroy incoming **enemy missiles at different altitudes** in the endo-atmosphere and exo-atmosphere
- The first phase envisages annihilating incoming missiles with a range of 2,000 km, while the second phase aims to destroy missiles having a range of more than 2,000 km

LIMITATIONS OF LAND SYSTEMS

- At the Wheeler Island range, affected villages **need to be evacuated** every time a trial takes place
- Missile range has to be confined to **less than 300 km**

CURRENT STATUS

The construction has just started. It may take **three to four years** for the ship to be ready to conduct the first trial

- The state-of-the-art range would have many facilities such as a launch-pad, a launch control centre and a mission control pad would be ideal.

BMD:

- The system seeks to engage and destroy incoming enemy missiles at different altitudes in the
 - Endo atmosphere – (less than 30 Km) – Advanced Air Defense (AAD)/Ashwin Ballistic Missile Interceptor and
 - Exo-atmospheres. (50 - 80 Km) – Prithvi Air Defense (PAD)/ Pradyumna
- **Phase I** - Development of interceptors to destroy incoming missiles with a range of 2,000 km.
- **Phase II** - Aims to build such weapons to destroy missiles with a longer range.
- India has so far conducted 10 interceptor missile tests, eight of them successful. Most of the trials were conducted in the endo-atmosphere, and a few in the exo-atmosphere.

The first phase of the system is expected to be deployed after some more interceptor trials in deployable configuration.

Integrated Air Command and Control System (IACCS):

Why in news: The government has cleared the proposal for a nearly Rs 8,000-crore project for IAF's Integrated Air Command and Control System (IACCS).

Features:

- IACCS is an automated command and control system for Air Defence (AD) planned by the Indian Air Force.
- It will detect and tackle enemy and terror aerial threats in real-time by putting in place a composite and enhanced surveillance capability.
- With the help of this the air headquarters will get a composite air situation picture since it will be integrating Air Force, Army, Naval and civilian radars.
- It enables the surveillance of national airspace for airspace safety and Air traffic operations.
- It helps in real time transportation of data, voice and images among stations and aircrafts.

2.9. CLOUD SEEDING

Why in News: The Karnataka State government has decided to take up cloud seeding to overcome the crisis in the agricultural sector owing to deficient rainfall this year.

- Cloud seeding, a form of weather modification, is an attempt to change the amount or type of precipitation that falls from clouds, by dispersing substances into the air that serve as cloud condensation or ice nuclei.
- **Chemicals used:** Silver iodide, potassium iodide and dry ice (solid carbon dioxide). Liquid propane

Uses:

- To increase rainfall in a particular area.
- To prevent hail and fog

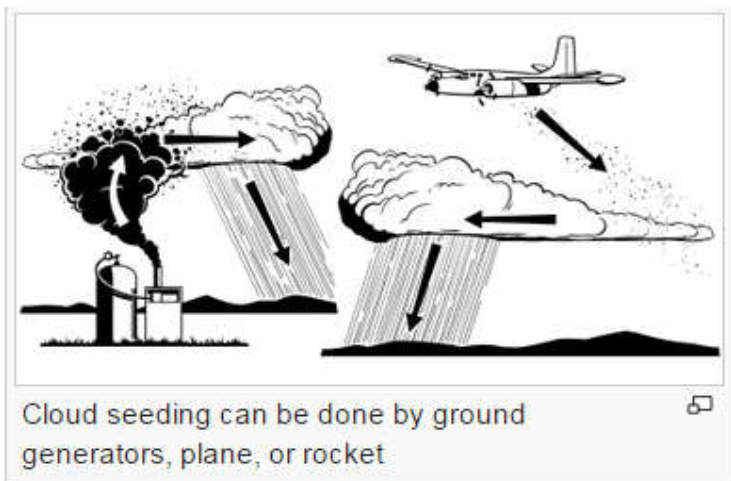

2.10. SILAGE

What it is: Silage, a green fodder compacted in air tight conditions to be used as substitute for green fodder during the lean period for livestock

Uses:

- Potential fodder for livestock living in the rain shadow areas
- Can be used as alternative during dry period
- Potential to increase the milk yield

Why in News: Tamilnadu government has embarked upon a programme to popularise silage making. Scientists of Tamil Nadu Veterinary University Training and Research Centre at Karur demonstrated the silage making by using repol polypropylene (silage bags)

Method of Silage Preparation

- Green grass mass is stored in large sacks made from polythene
- Once the bag is filled, the material is pressed to remove the air and thereby preventing decomposition.

After that it is fermented by adding diluted molasses and preserved for 60 days at appropriate moisture levels.

2.11. KALPAKKAM FAST BREEDER REACTOR TO BE COMMISSIONED SOON

- The 500-MWe Prototype Fast Breeder Reactor (PFBR) at Kalpakkam is getting ready to be commissioned in September.
- It will signal India's triumphant entry into the second stage of its three-stage nuclear power programme.
- **Fuel:** plutonium-uranium oxide
- **Coolant:** liquid sodium
- **What is FBR:** A reactor, which produce more fuel than it consumes. India's FBRs will produce xxx while generating power.
- **Current status:** The PFBR construction had been completed and equipment energised. The agency is awaiting clearance from the Atomic Energy Regulatory Board (AERB) for sodium charging, fuel loading, reactor criticality and then stepping up power generation.
- **Who build reactors:** Bharatiya Nabikhiya Vidyut Nigam Limited (BHAVINI), a public sector undertaking of the Department of Atomic Energy.

2.11.1. INDIA'S 3 STAGE NUCLEAR PROGRAMME

- **India's three-stage nuclear power programme** was formulated by Dr. Homi Bhabha in the 1950s to secure the country's long term energy independence, through the use of uranium and thorium reserves found in the monazite sands of coastal regions of South India.
- Motivation behind this programme: India has 25% of world thorium reserves but only 1-2% global uranium reserve. So

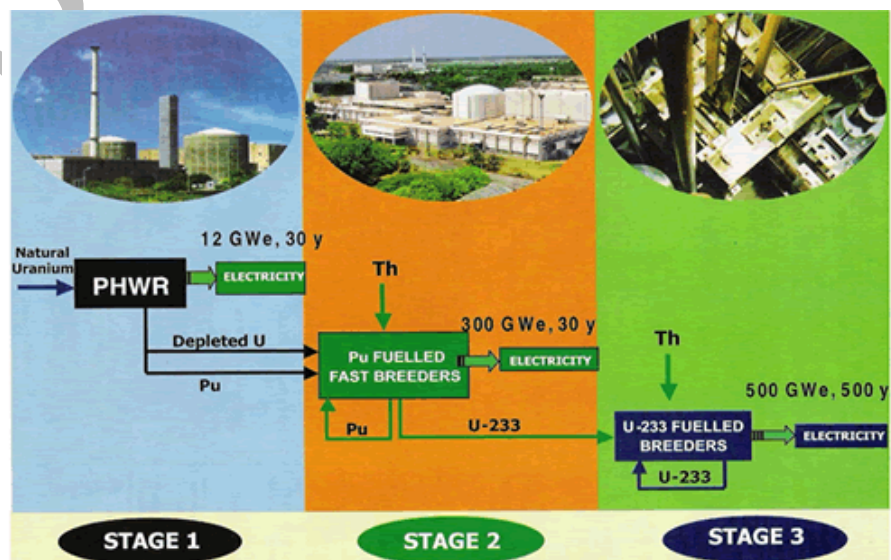

it will enable the thorium reserves of India to be utilised in meeting the country's energy requirements.

- The recent Indo-US Nuclear Deal and the NSG waiver, which ended more than three decades of international isolation of the Indian civil nuclear programme, have created many hitherto unexplored alternatives for the success of the three-stage nuclear power programme.

Stage 1: Pressurised Heavy Water Reactor:

In this natural uranium fuelled pressurised heavy water reactors (PHWR) produce electricity while generating plutonium-239 as by-product.

Stage II – Fast Breeder Reactor:

- In the second stage, fast breeder reactors (FBRs) would use a mixed oxide (MOX) fuel made from plutonium-239, recovered by reprocessing spent fuel from the first stage, and natural uranium.
- In the second stage, fast breeder reactors (FBRs) would use a mixed oxide (MOX) fuel made from plutonium-239, recovered by reprocessing spent fuel from the first stage, and natural uranium.
- In FBRs, plutonium-239 undergoes fission to produce energy, while the uranium-238 present in the mixed oxide fuel transmutes to additional plutonium-239.
- Thus, the Stage II FBRs are designed to "breed" more fuel than they consume.

Stage III – Thorium Based Reactors:

- A Stage III reactor or an advanced nuclear power system involves a self-sustaining series of thorium-232-uranium-233 fuelled reactors.
- This would be a thermal breeder reactor, which in principle can be refuelled after its initial fuel charge using only naturally occurring thorium.
- According to the three-stage programme, Indian nuclear energy could grow to about 10 GW through PHWRs fuelled by domestic uranium, and the growth above that would have to come from FBRs till about 50GW.
- The third stage is to be deployed only after this capacity has been achieved.
- Full exploitation of India's domestic thorium reserves will likely not occur until after the year 2050.

3. TOPIC: SPACE

3.1. CHANDRAYAAN 2

- It will be India's second mission to the Moon, is an advanced version of the previous Chandrayaan-1 mission.
- It consists of **an Orbiter, Lander and Rover configuration**.
- It is planned to be launched as a composite stack into the Earth Parking Orbit (EPO) by GSLV-Mk II.
- The Orbiter with scientific payloads will orbit around the moon. The Lander will **soft land on the Moon at a specified site and deploy the Rover**.
- The scientific payloads onboard the Orbiter, Lander and Rover are expected to perform **mineralogical and elemental studies** of the lunar surface.
- During 2010, it was agreed that Russian Space Agency ROSCOSMOS would be responsible for "lunar Lander" and ISRO will be responsible for Orbiter and Rover as well as Launch by GSLV.
- Later, due to a shift in the programmatic alignment of this mission, it was decided that the Lunar Lander development would be done by ISRO and **Chandrayaan-2 will be totally an Indian mission**.

3.2. ADITYA-1

- It is India's first dedicated scientific mission to study sun.
- This is **low earth orbit (LEO)** mission at an altitude of 800 Km. It will provide high time cadence sharp image of **solar corona**.
- These images will be used to study the highly dynamic nature of the solar corona including the small scale coronal loops and large scale **coronal mass ejections (CMEs)**.
- These studies will enhance our current understating of the Solar Corona and also provide vital data for **space weather studies**.
- **What is Solar Corona?**
 - A corona is an aura of plasma (4th state of matter) that surrounds the sun and other celestial bodies.
 - The Sun's corona extends millions of kilometers into space and is most easily seen during a total solar eclipse.

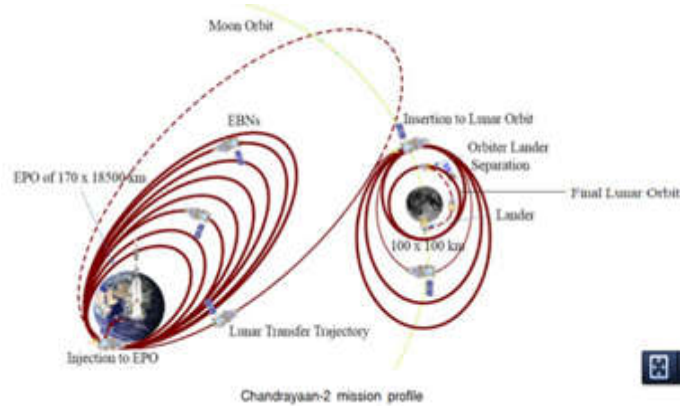

3.3. PROBLEM OF WASTE DEPOSITS IN SPACE

Space debris, also known as orbital debris, space junk, and space waste, is the collection of defunct objects in orbit around Earth. This includes everything from spent rocket stages, old satellites, fragments from disintegration, erosion, and collisions. Since orbits overlap with new spacecraft, debris may collide with operational spacecraft.

Space debris populations seen from outside geosynchronous orbit (GEO). Note the two primary debris fields, the ring of objects in GEO, and the cloud of objects in low earth orbit (LEO).

As the chance of collision is influenced by the number of objects in space, there is a critical density where the creation of new debris is theorized to occur faster than the various natural forces remove them. Beyond this point, a runaway chain reaction may occur that would rapidly increase the number of debris objects in orbit, and therefore greatly increase the risk to operational satellites. Called the "Kessler syndrome", there is debate if the critical density has already been reached in certain orbital bands. A runaway Kessler syndrome would render a portion of the useful polar-orbiting bands difficult to use, and greatly increase cost of space launches and missions. Measurement, growth mitigation and active removal of space debris are activities within the space industry today.

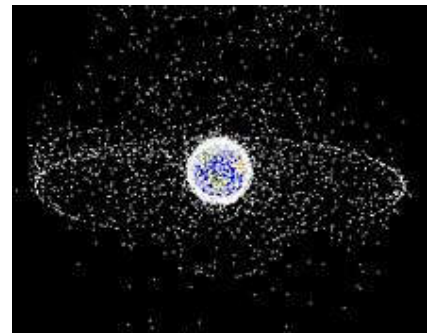

India has done studies related to waste deposits in space referred as Space Debris and successfully developed methodologies and software tools. ISRO performs Space Object Proximity Analysis for its operational Low Orbit spacecraft on a regular basis to assess the collision risk and determine risk mitigation strategies in advance. Collision Avoidance analysis is also carried out to identify the safe lift-off time for launching of satellites from Sriharikota. The growing space debris poses threat to present and future space activities, globally, in terms of collision risk. ISRO has taken mitigation measures like passivation of spent upper stage of launch vehicles and de-orbiting of non-functional satellites to avoid creation of space debris. ISRO has also undertaken collaborative studies with other space agencies to control and restrict this outer space contamination. India is an active member of Inter Agency Space Debris Co-ordination Committee (IADC) and played a key role in evolving space debris mitigation guidelines formulated by IADC and United Nations Committee on the Peaceful Uses of Outer Space (UNCOPUOS).

3.4. CASPOL

The new compound, christened **CASPOL**, is a **water-based, ready-to-coat, and easy-to-use flame-proof coating**.

- It has flame-retardant and thermal-control properties.
- It can be applied on walls, clothes, paper, thatched roofs, wood, and other materials.
- The new compound contains no toxic materials and is eco-friendly.
- A litre of Caspol can coat 1.5 sq. meter of surface with a thickness of 500 microns, which is practically adequate for fire protection and thermal insulation.

It is developed by the Indian Space Research Organisation (ISRO) to protect the fuel tanks of the Polar Satellite Launch Vehicle.

Uses:

- The compound can be used **as a flame-retardant material** for railway coaches and automobiles.
- Shopping malls, theatres, and other closed public places, which are vulnerable to fire, can be made fire-resistant by using the compound.
- It can be applied over concrete surfaces of buildings to **prevent water seepage** as it can fill micro-cracks and holes effectively. The ISRO says it helps keep buildings cooler by at least 5 to 6 degrees Celsius.

3.5. GOLDILOCKS ZONE

The Goldilocks region is an area of space in which a planet is just the right distance from its home star so that its surface is neither too hot nor too cold.

Astronomers with the Harvard-Smithsonian Centre for Astrophysics (CfA) have discovered eight new planets within the so-called Goldilocks — or habitable — zone of their stars.

To be considered habitable, exoplanets must orbit within a distance of their stars in which liquid water can exist on the planet's surface, receiving about as much sunlight as Earth.

The discoveries of Kepler-438b and Kepler-442b are the latest in several advancements scientists have made to find signs of possible life in the universe.

- The couple most like Earth, Kepler-438b and Kepler-442b, both orbit red dwarf stars, which are cooler and smaller than the Earth's sun.
- Kepler—438b's diameter is 12 per cent bigger than Earth and has a 70 per cent chance of being rocky, which means the surface of the planet appears to be like Earth's.
- Kepler—442b is about one-third larger than Earth with a 60 per cent chance of being rocky. Scientists give it a 97 per cent chance of being in the habitable zone.

3.6. BEAGLE 2

Beagle 2 is a British landing spacecraft that formed part of the European Space Agency's 2003 Mars Express mission. Beagle 2 is named after Beagle. Beagle 2 -- which measures less than 2 metres across -- was named after the ship Charles Darwin sailed when he formulated his theory of evolution.

- Beagle 2 had been due to land on Mars on Christmas Day 2003, but went missing on December 19, 2003.
- ESA declared the mission lost in February 2004, after numerous unsuccessful attempts to contact the spacecraft were made.
- The spacecraft's fate remained a mystery until it was found in January 2015.
- Beagle 2 had been located intact on the surface of Mars by NASA's Mars Reconnaissance Orbiter HiRISE instrument.

Reason of failure: one of the part on which the solar panels of the lander are mounted failed to fully open, preventing deployment of its radio antenna and blocking communication. Because of this communication failure contact was lost to the spacecraft and it was declared lost by ESA.

3.7. CERES

Ceres is a dwarf planet located in the asteroid belt, which lies between the orbits of Mars and Jupiter. It was originally classified as a true planet in the 1800s, then demoted to an asteroid and finally in 2006 promoted again as a “dwarf planet” — a status it now shares with Pluto. At 950 km diameter Ceres is the smallest known dwarf planet, but the largest object in the asteroid belt between Mars and Jupiter.

- NASA’s Dawn spacecraft has sent back a picture of Ceres taken from a distance of 237,000 km.
- Dawn will enter into Ceres’ orbit on March 6 to capture detailed images and measure variations in reflected light to get insights into the planet’s surface composition.
- Dawn will be the first spacecraft to visit any dwarf planet

3.8. MARS ONE

Mars One is a not-for-profit organization based in the Netherlands that has put forward plans to land the first humans onto Mars and establish a permanent human colony there by 2025.

Project:

- It is a project aimed at establishing a permanent human settlement on Mars.
- The mission plans to initially send four astronauts in 2025 on a one-way trip to Mars where they would spend the rest of their lives building the first permanent human settlement.
- Mars One will select and train for 8 years the human crew for permanent settlement.
- The first trip to Mars (carrying four candidates) is expected to commence in 2024 and will last for about eight months. Every two years from then, the other candidates will travel until all 24 reach Mars.

Criticisms: The project’s schedule, technical and financial feasibility as well as ethics have been criticized by scientists, engineers and those in the aerospace industry.

Why in news:

- Three Indians, two women and one man, have made it to the list of 100 applicants who will move on to the next round of an ambitious private mission that aims to send four people on a one-way trip to Mars in 2024.
- From the initial 202,586 applicants, only 100 have been selected to proceed to the next round of the Mars One Astronaut Selection Process.

3.9. SOLAR POWER STATION IN SPACE

Space Solar Power gathers energy from sunlight in space and transmits it wirelessly to Earth. Space solar power can solve our energy and greenhouse gas emissions problems. The solar energy available in space is literally billions of times greater than we use today.

Advantages of Space Solar Power:

- Unlike oil, gas, ethanol, and coal plants, space solar power does not emit greenhouse gases.
- Unlike terrestrial solar and wind power plants, space solar power is available 24 hours a day, 7 days a week, in huge quantities. It works regardless of cloud cover, daylight, or wind speed.
- Space solar power will provide true energy independence for the nations that develop it, eliminating a major source of national competition for limited Earth-based energy resources.

- Space solar power can be exported to virtually any place in the world, and its energy can be converted for local needs — such as manufacture of methanol for use in places like rural India where there are no electric power grids. Space solar power can also be used for desalination of sea water.

Chinese plan:

- China plans to build a huge solar power station 36,000 kilometres above the ground in an attempt to battle smog, cut greenhouse gases and solve energy crisis.
- The power station would be a super spacecraft on a geosynchronous orbit equipped with huge solar panels. The electricity generated would be converted to microwaves or lasers and transmitted to a collector on Earth.
- Countries such as the US and Japan have studied space solar power station. Japan leads the development of wireless power transmission technology.
- The electricity generated from the ground-based solar plants fluctuates with night and day and weather, but a space generator collects energy 99% of the time. Space-based solar panels can generate ten times as much electricity as ground-based panels per unit area.

Challenges:

- A commercially viable space power station would weigh 10,000 tons. But few rockets can carry a payload of over 100 tons to low Earth orbit.
- It requires a cheap heavy-lift launch vehicle.

3.10. 25 YEARS OF THE HUBBLE SPACE TELESCOPE

- The Hubble Space Telescope — a joint venture between NASA and the European Space Agency (ESA) — was launched in its orbit 552 km above Earth on April 24, 1990 by the space shuttle Discovery.
- The Hubble Telescope has the ability to see in multiple wavelengths — near-infrared, visible light and near-ultraviolet.
- Determination of the Hubble constant — the universe's initial rate of expansion was one of Hubble Space Telescope's key projects
 - ✓ One of the first achievements of HST was to determine the rate at which our universe has been expanding.
 - ✓ This was one of the key projects of the telescope, and it was aptly named after Edwin Hubble, the discoverer of the expansion of the universe.
 - ✓ A value of $H_0 = 74 \pm 3$ km per second per million parsecs is most quoted today. But the Sandage and Tammann group still favour a lower value of $H_0 = 62 \pm 6$ km per second per million parsecs.
- Hubble proved the existence of super-massive black holes and found they're located at the centre of most galaxies.
- It also helped to pinpoint the age of the universe at 13.8 billion years old.

3.11. NEW HORIZONS

New Horizons is a NASA space probe launched to study the dwarf planet Pluto, its moons and one or two other Kuiper belt objects. The spacecraft is scheduled to pass through the Pluto system on July 14, 2015 and will map the dwarf planet, its five known moon's surface and search for a ring system.

- NASA probe, New Horizons, passed Neptune's orbit, nearly 25 years after Voyager 2 spacecraft executed the first-ever flyby of faraway Neptune and its icy moon Triton.

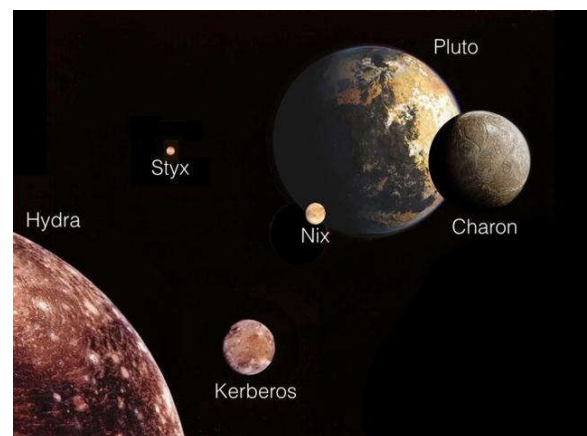

Pluto's moons:

- Pluto has five known moons – Charon, Hydra, Nix, Kerberos and Styx.

The Kuiper Belt:

- The **Kuiper belt** sometimes called the **Edgeworth–Kuiper belt**, is a region of the Solar system beyond the planets, extending from the orbit of Neptune (at 30 AU) to approximately 50 AU from the Sun.
- The **astronomical unit (AU)** is a unit of length, roughly the distance from the Earth to the Sun.

3.12. MESSENGER (MERCURY SURFACE, SPACE ENVIRONMENT, GEOCHEMISTRY, AND RANGING) SPACECRAFT

MESSENGER (an acronym of **Mercury Surface, Space Environment, Geochemistry, and Ranging**, and a reference to the mythological messenger, Mercury) was a robotic NASA spacecraft which orbited the **planet Mercury between 2011 and 2015**.

- NASA's Messenger spacecraft, launched in 2004, began orbiting Mercury in 2011.
- Spacecraft has crashed into the surface of Mercury, ending its historic 11-year mission that provided valuable data and thousands of images of the planet. (Orbited for 4 years)

Findings of Mission:

- Its **objective** was to study Mercury's **chemical composition, geology, and magnetic field**.
- Unexpectedly **high concentrations** of **magnesium** and **calcium** found on Mercury
- Mercury's magnetic field is offset far to the north of the planet's centre
- visual evidence of past **volcanic activity** on the surface of Mercury
- Both **water ice and organic compounds** in permanently shadowed craters in Mercury's north pole
- MESSENGER was able to take highly detailed close-up photographs of ice-filled craters and other landforms at Mercury's north pole.

3.13. INDIA TO TEST REUSABLE LAUNCH VEHICLE IN JULY: ISRO

- This launch vehicle (1.5 tonne) will be mounted on the Polar Satellite Launch Vehicle (PSLV) rocket.
- At an altitude of 70 km, the model would get separated and would glide back to earth.
- The descent speed would be controlled through the fins on the machine.
- Last December, ISRO sent up a 3.7 tonne giant module-called Crew Module Atmospheric Re-entry Experiment- to study its re-entry characteristics, aero-braking and validation of its end-to-end parachute system.
- It will bring down costs significantly of launching satellites. It will reduce the cost by one-tenth.



3.14. SAKAAR

Sakaar is Indian Space Research Organization's (ISRO) Augmented Reality (AR) application designed for Android devices. (Refer Augmented reality from Emerging Technology section)

- It consists of 3D models of MOM, RISAT, rockets (PSLV, GSLV Mk-III); videos of INSAT 3D-predicting cyclones, GSLV D5/Cryo, Mars Orbiter Mission (MOM) orbit insertion, launch video of MOM, 360-degree animated view of MOM; Anaglyph of Mars surface.

3.15. INTERNATIONAL SPACE STATION (ISS)

- The **International Space Station (ISS)** is a space station, or a habitable artificial satellite, in low Earth orbit.
- ISS is now the largest artificial body in orbit and can often be seen with the naked eye from Earth.
- The station is suited for the testing of spacecraft systems and equipment required for missions to the Moon and Mars.
- The ISS serves as a space environment research laboratory in which crew members conduct experiments in biology, human biology, physics, astronomy, meteorology and other fields.

Why in News: US SpaceX's rocket with a Dragon cargo ship carrying supplies to the International Space Station (ISS) exploded three minutes after it had been launched.

3.16. PHILAE

What is Philae: It is a robotic European Space Agency lander that accompanied the Rosetta spacecraft until it landed on comet 67P/Churyumov-Gerasimenko, more than ten years after departing Earth. On 12 November 2014, the probe achieved the first-ever soft landing on a comet nucleus.

Why in News: On 15 November 2014, Philae entered safe mode, or hibernation, after its batteries ran down due to reduced sunlight and an off-nominal spacecraft orientation at its unplanned landing site. Mission controllers

hoped that additional sunlight on the solar panels by August 2015 might be sufficient to reboot the lander. On 13 June 2015, Philae began communicating with Rosetta again.

What is Rosetta: Mothership (spacecraft) orbiting Comet 67P. Philae communicates with Rosetta which sends the received data to the earth.

Goals of the mission :

- To focus on **elemental, isotopic, molecular and mineralogical composition** of the cometary material
- The characterization of physical properties of the surface and subsurface material
- The large-scale structure and the **magnetic and plasma environment** of the nucleus
- The mission seeks to unlock the long-held secrets of comets — **primordial clusters of ice and dust** that scientists believe may reveal how the Solar System was formed.

3.17. ISRO SUCCESSFULLY LAUNCHED 5 UK SATELLITES

- Heaviest ever payload (1,440kg)
- Launched by 44.4-metre-tall **Polar Satellite Launch Vehicle PSLV-C28**
- Satellites launched
 - UK's three identical optical earth observation satellites
 - A Micro and a Nano satellite from UK
- Will give a boost to ISRO's commercial launch capabilities
- ISRO's previous 'heavy' commercial payload was SPOT-7, a French satellite weighing 712kg that a PSLV put in orbit in 2014.
- Major application areas of satellites include surveying the resources on earth and its environment, managing urban infrastructure and monitoring of disasters.

3.18. SAARC SATELLITE EXPECTED TO BE LAUNCHED IN DECEMBER 2016

SAARC Satellite is a proposed communication-cum-meteorology satellite by Indian Space Research Organisation (ISRO) for the SAARC region.

Features:

- Will have twelve 'Ku' transponders
- PM Modi in June 2014 had asked ISRO to develop a SAARC satellite which can be dedicated as a "gift" to the neighbouring countries
- It will be a communication satellite and will provide them opportunity to make use of the transponder for their own use, whether it is education, tele-medicine or disaster monitoring and other need based services.
- It will have the capability to interconnect all these eight countries. Interconnection will be like
 - Hot contact for the political level
 - MEA interconnection
 - Disaster monitoring constellation
 - Meteorological data dissemination

3.19. GPS-AIDED GEO AUGMENTED NAVIGATION (GAGAN) SYSTEM

- Government launched the GPS-Aided Geo Augmented Navigation (GAGAN) system thereby joining a select league comprising the US, Europe Union (EU) and Japan which have similar systems. The Indian Space Research Organisation (ISRO) and the Airports Authority of India (AAI) developed the system.

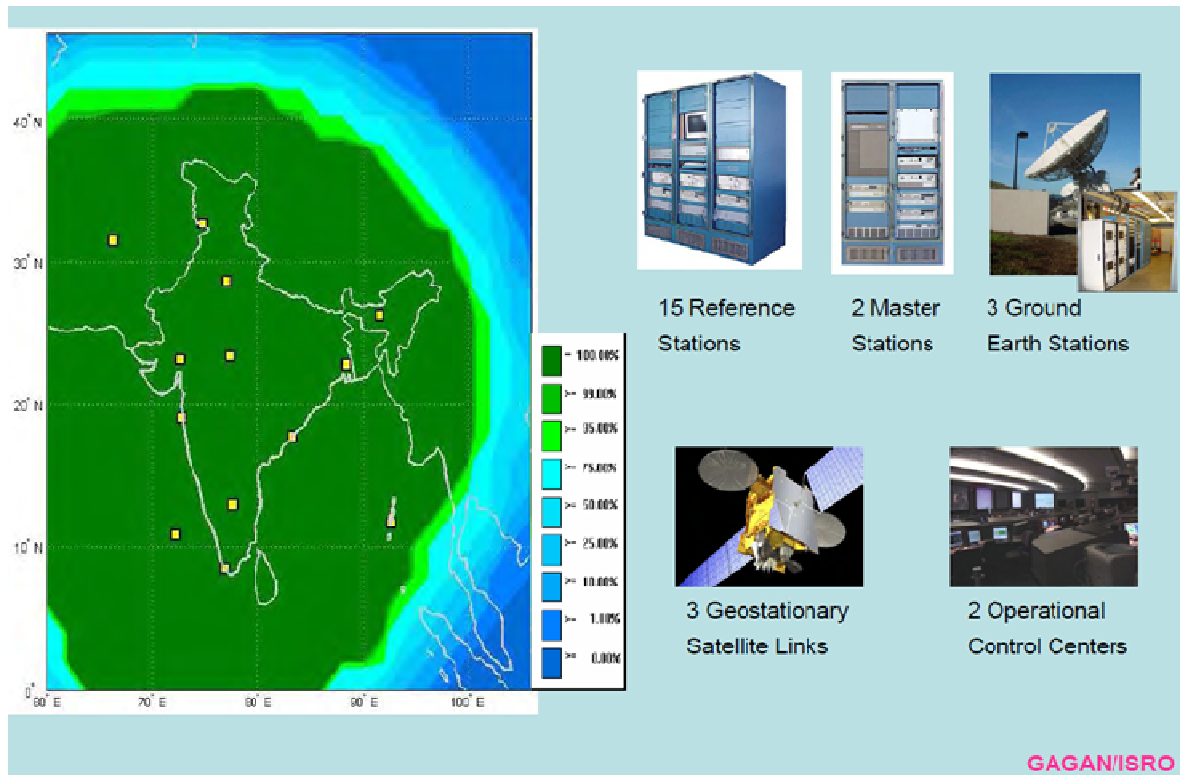

Features and Significance:

- Gagan works by augmenting and relaying data from GPS satellites with the help of two augmentation satellites and 15 earth-based reference stations.
- 3 Geostationary Satellites: GSAT-8, GSAT-10 and GSAT-15
- GAGAN system corrects any anomalies in the position data and gives accurate routes, landing guidance and time saving information to the pilots.
- The system also bridges the gap in the coverage areas of the European Union's European Geostationary Navigation Overlay Service (EGNOS) and Japan's Multi-Functional Satellite Augmentation System (MSAS).
- GAGAN will provide augmentation service for the GPS over the country, the Bay of Bengal, South East Asia and Middle East and up to Africa.
- The guided approach landing with the help of GAGAN would immediately benefit nearly 50 airports in India.
- The system would be available for the member states of the South Asian Association for Regional Cooperation (SAARC).
- It will be able to help pilots to navigate in the Indian airspace by an accuracy of 3 m. This will be helpful for landing aircraft in tough weather and terrain like Mangalore and Leh airports.
- Some more benefits are
 - Improved efficiency,
 - Direct routes,
 - Increased fuel savings,
 - Significant cost savings because of the withdrawal of ground aids and reduced workload of flight crew and air traffic controllers and Accurate guidance for planning shorter routes and safer landing patterns is expected to provide the aviation sector cost-saving options.

FOR A SAFE AND SMOOTH FLIGHT

India becomes fourth nation to offer satellite-based navigation services to aviation sector

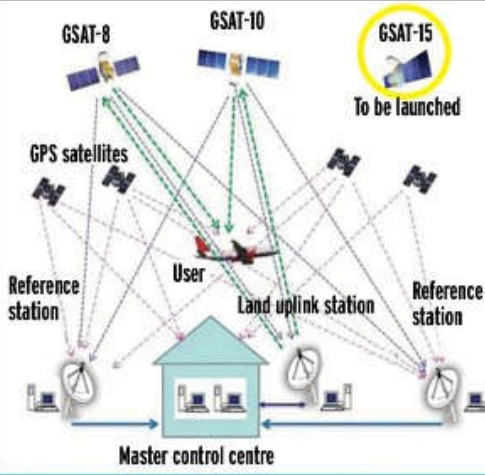

➤ GAGAN has been developed by ISRO and Airports Authority of India **over 15 years at an estimated cost of Rs.774 crore**

➤ The new navigation system **will benefit 50 operational airports in India for now**

ADVANTAGES

➤ Enhances capacity of the airspace by **reducing separation between aircraft**

➤ **Augments GPS signals over Indian land mass, Bay of Bengal, Southeast Asia, Middle East and expanding up to Africa**

➤ Streamlines airline operations, **increases air safety and fuel efficiency**

- GSAT-8 and GSAT-10 satellites will provide navigation signals
- Reference and uplink stations will verify GPS signals
- GPS receivers will help in precision guidance for landing of aircraft

Criticisms:

The technology has one major drawback that only those aircraft that are fitted with satellite-based wide area augmentation system (SBAS) will be able to use the new technology.

3.20. ISRO'S TITANIUM SPONGE PLANT IN KERALA FULLY COMMISSIONED

- The indigenous Titanium Sponge Plant at Chavara in Kerala has been fully commissioned and has started commercial production required for space applications.
- The national Space programme can now fully bank on made-in-India titanium sponge that goes into making its satellite and launch vehicle parts.
- This is the only integrated plant in the world that undertakes all activities right from mining of Ti minerals to manufacturing of aerospace grade Ti sponge under one roof.

Significance:

- Now, India has become the seventh country in the world producing Titanium sponge commercially.
- Big saving of forex reserve as earlier India used to import titanium.
- India is endowed with the third largest reserve of Titanium bearing minerals.
- **Annual requirement:** 200-300 metric tonnes.

Why Titanium is required in Aerospace and Defence equipments: high strength and non-corrosive quality.

3.21. GSLV D6 SUCCESSFULLY LAUNCHED

- The GSLV D-6 is the second successful consecutive launch (earlier launch GSLV D-5 in January) of the GSLV series with indigenous cryogenic upper stage.
- ISRO is planning to test GSLV Mk III capable of carrying payload up to four tonne by the end of next year.

Difference between Cryogenic stage and other stages:

- The cryogenic stage is technically a very complex system, as compared to solid liquid propellant stages, due to its use of propellants at extremely low temperature (cryo) and the associated thermal and structural challenges. A cryogenic rocket stage is more efficient and provides more thrust for every kilogram of propellant it burns.

Significance:

- 2 consecutive successful launches proved the capability of ISRO and enhanced its confidence.
- GSLV will cost just one third of money spent on foreign agencies, which will reduce satellite launch cost as well as will save forex.
- It will **enhance India's capability to be a competitive player** in the multimillion dollar commercial launch market. It will help in earning foreign exchange.
- The GSLV will help ISRO put heavier communication satellites of GSAT class into orbit.
- Reduction of dependence on foreign agencies gives strategic boost in this high tech sector

3.22. GSAT-6 (GEOSYNCHRONOUS SATELLITE)

- It is aimed at primarily benefiting the country's strategic users and other specific authorised users.
- It has life of nine years and 2 tonne launch mass.
- It will provide S-band communication services in the country.
- It includes a first-of-its-kind S-Band antenna with a diameter of six meter. This is the largest antenna ISRO has ever made for a satellite.
- It will offer a Satellite Digital Multimedia Broadcasting (S-band) service, via mobile phones and mobile video/audio receivers for vehicles.
- It can also be utilized for strategic and social applications.

ISRO SUCCESS STORY SOARS TO NEW HEIGHTS

ISRO proved beyond doubts its cryogenic expertise after launching the GSLV-D6 (left) placing GSAT-6 (below) in orbit

CRYOGENIC CAPABILITY

FACTOIDS

- POSITION: 83 Degree East Longitude
- LAUNCH MASS: 2,117 kg
- SATELLITE MASS: 985 kg
- DIMENSION: 2.1 x 2.5 x 4.1 m
- MISSION LIFE: NINE years
- GENERATED POWER: 3,100 W

EYE IN THE SKY

- ➔ GSAT-6 is the 25th geostationary communication satellite of India built by ISRO and 12th in the GSAT series
- ➔ Five of GSAT-6's predecessors were launched by GSLV during 2001, 2003, 2004, 2007 and 2014 respectively
- ➔ GSAT-6 provides communication through five spot beams in S-band and a national beam in C-band for strategic users

THE TAKEOFF

GSLV-D6 lifted off from Sriharikota at 4.52 pm. Seventeen minutes later, the rocket injected GSAT-6 into Geosynchronous Transfer Orbit

Another day & another phenomenal accomplishment by our scientists. Congratulations @isro for the successful launch of GSAT-6 - PM NARENDRA MODI ON TWITTER

Source: ISRO

GRAPHIC: KARTHICK S.T.

3.23. MULTI-APPLICATION SOLAR TELESCOPE (MAST) OPERATIONALIZED AT UDAIPUR SOLAR OBSERVATORY (USO)

Purpose and significance:

- Detailed study of the Solar activity including its magnetic field. This study of solar activities would facilitate space weather predictions in the future.
- Capable of capturing three-dimensional aspects of the solar magnetic fields further enabling the scientists to get a better understanding of the solar flares and eruptions taking place in such twisted magnetic fields.
- USO is a part of Physical Research Laboratory (PRL), which is an autonomous unit of the Department of Space.

- The observatory is situated on an island in the middle of Fatehsagar lake.

Why observatory is made in the middle of lake:

- Large water body surrounding the telescopes decreases the amount of heating of the surface layers.
- This decreases the turbulence in the air mass and thereby improves the image quality and seeing.

Features of MAST:

- 50 cm aperture
- Off-axis Gregorian-Coude telescope

Other Telescopes in India:

Name/Observatory	Aperture	Year	Location
National Large Solar Telescope	200 cm	proposed	Merak Village, Ladakh,
ARIES Observatory	15 cm	1961–	Nainital,
Solar Tunnel Telescope, Kodaikanal Solar Observatory	61 cm (24 in)	1958–	Kodaikanal,

3.24. SEMI-CRYOGENIC LAUNCH VEHICLE

- ISRO signed MoU with Russian space agency to boost its plan for Semi-cryogenic launch vehicle.
- ISRO's third rocket development programme
- Cost: Rs. 1,800-crore
- Fuel: space-grade kerosene and liquid oxygen
- Capacity: six to ten tonnes to heights of 36,000 km.
- Currently only the U.S. and Russia have this technology
- Future: According to ISRO it will be ready with the engine [SCE-200] in six to eight months.
- This would be double the lifting power of the GSLV and triple that of the PSLV.

3.25. ASTROSAT

Astrosat is India's first dedicated astronomy observatory to study distant celestial object. ASTROSAT is seen as a smaller version of NASA's Hubble Space Telescope. The Space Observatory will be able to detect objects in multiple wavelengths such as X-rays and UV, but with far lower precision than Hubble launch Vehicle

- It was launched by PSLV-C30 along with six tiny satellites from foreign countries including US.
- This is the first time that an Indian rocket launched satellites from the US.
- 30th consecutive successful launch of PSLV.

Till now, Indian scientists had to rely on the telescopes and platforms operated by NASA and the European Space Agency to study radiation bands that carry information about neutron stars, newly born or

Features of ASTROSAT:

- **Uniqueness:** With the help of its six payloads, it enables simultaneous multi-wavelength observations of various astronomical objects with a single satellite.
- **Payloads:** 4 X-ray payloads, 1 UV telescope and charge particle monitor
- 178 cr, 1513 Kg satellite will be placed in 650 kms near equatorial orbit.
- Projected life term: - 5-years.
- Joint collaboration between ISRO, TIFR, BAARC, Indian Institute of Astrophysics, Bengaluru and the Inter - University Centre for Astronomy and Astrophysics, (IUCCA), Pune.

exploding stars and the spiralling hot gases around black holes. Now, Astrosat's telescope can help them in their study and search for answers

Main scientific focus on:

- Understand high energy processes in binary star systems containing neutron stars and black holes.
- Estimate magnetic fields of neutron stars.
- Study star birth regions and high energy processes in star systems lying beyond our galaxy.

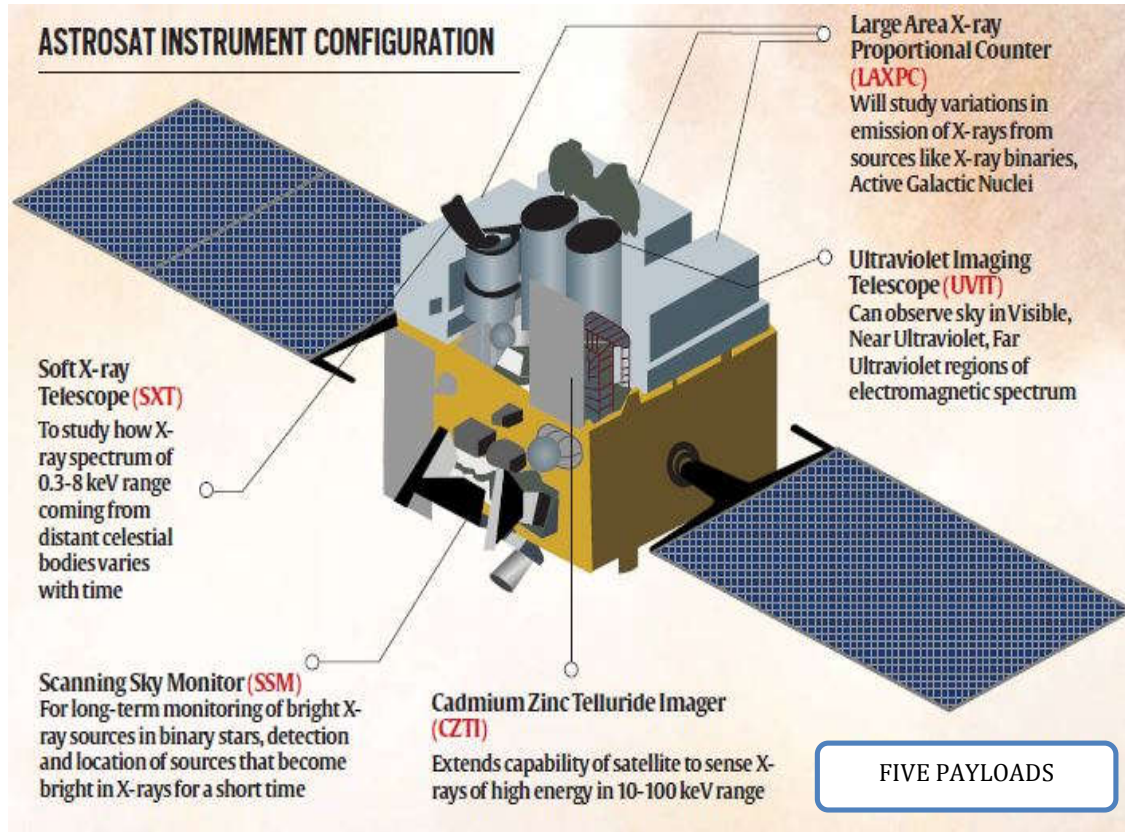

- Detect new briefly bright X-ray sources in the sky.
- Perform a limited deep field survey of the Universe in the ultraviolet region.

Significance

- An open observatory (after one year) with proposal driven research approach.
- Will provide useful data and big boost for the country's astronomy community.
- It will put India in an elite orbit with the U.S., Europe, Russia and Japan.

3.26. LAPAN A2/ORARI

An Indonesian satellite launched by India, along with ASTROSAT on board PSLV C30.

Functions and Features

- Multi-Spectral remote sensing satellite
- To monitor land-use, natural resource and in disaster mitigation, ship movements, sea resources and fishing explorations.
- Successor to LAPAN A1 (also launched by India in 2007)

3.27. NASA'S SERVIR-MEKONG PROJECT

Launched by National Aeronautics and Space Administration (NASA) and the US Agency for International Development (USAID)

Countries that will be benefitted: Cambodia, Laos, Myanmar, Thailand and Vietnam

Functions and significance:

- It will provide timely weather, climate and other Earth related data.
- It will enable to better address issues of natural resource and disaster management.
- It will strengthen regional environmental monitoring.
- The partnership chiefly is intended to support climate resilience studies, providing early warning of dramatic changes in regional water, food security, weather and climate, and land cover and land use of the entire Mekong River Basin.

3.28. MISSION ON MARS (MANGALYAAN) - A TECHNOLOGY DEMONSTRATOR MISSION

- Marking India's first venture into the interplanetary space, MOM is aimed to explore and observe Mars surface features, morphology, mineralogy and the Martian atmosphere. Further, a specific search for methane in the Martian atmosphere will provide information about the possibility or the past existence of life on the planet.

Features:

- It is launched by using a Polar Satellite Launch Vehicle (PSLV) rocket C25.
- It costs 450 crore, weighed 1350 kg, travelled for 300 days covered 65 crore km @ 7Rs/km
- It Carried 5 instruments
 - Lyman-Alpha Photometer (LAP),
 - Methane Sensor for Mars (MSM)),
 - Particle environment studies (Mars Exospheric Neutral Composition Analyser (MENCA)),
 - Surface imaging studies (Thermal Infrared Imaging Spectrometer (TIS),
 - Mars Colour Camera (MCC)

Why in news:

It completed one year successfully on 24 September.

Key Findings:

The data filtering in from the payloads is yet to be fully analysed and published by scientist involved. Initial outcomes include:

- Water on Mars
- Increasing possibility of life on Mars.
- High quality images published in Mars Atlas.

Significance of the mission:

- **Cost effectiveness:** Technological benefits: The technology used in this mission has potential application in weather forecast, computer tech, health-medicine etc. in future
- **Success in first attempt:**
- **Economic Benefits:** As ISRO establishes reputation, gets more contracts from foreign countries and more foreign exchange.
- **Effects on foreign policy:** It can be used as a tool to exercise soft power by sending space missions of third world countries and SAARC countries.

- China and India recently signed an agreement on “peaceful uses of outer space.” So, many countries are now wanting to partner in ISRO’s success.
- Above all, such an achievement works as an inspiration and catalyst for innovation in the country and bringing more youth into the field of science.

Criticisms:

- Wastage of resources, given the socio economic condition of the country.
- Highly elliptical Orbit: Not ideal for clear observation of a planet.
- “Me too” mission: Due to limited payload capability of the PSLV, the mission lacked significantly science mission than one already performed by other Mars probe.

Should money be spent on such ventures?

- Humans are driven to explore the unknown, discover new worlds, push the boundaries of our scientific and technical limits, and then push further. The intangible desire to explore and challenge the boundaries of what we know and where we have been has provided benefits to our society for centuries.

4. TOPIC: BIOTECHNOLOGY

4.1. GENETICALLY EDITING HUMAN EMBRYOS

Group of scientists has raised ethical and safety concerns over genetically editing human embryos.

Argument against editing human embryos:

- ✓ This has the potential to create the designer baby using specific genes for greater intelligence or specific physical attributes such as blue eyes.
- ✓ This could have unpredictable effects on future generations.
- ✓ The scientist who are representing bioscience institutes in the U.S. — have called for a “voluntary moratorium” in the scientific community to discourage such research.

Argument in support of editing human embryos:

- ✓ Genome-editing technology does offer promising tools to correct disease-genes by snipping away harmful mutations to possibly treat human diseases such as HIV/AIDS, haemophilia, sickle-cell anaemia and forms of cancer.

4.2. CSIR SUCCEEDS IN WHOLE GENOME SEQUENCING OF HOLY BASIL (TULSI)

CSIR-Central Institute of Medicinal & Aromatic Plants (CSIR-CIMAP), has published whole genome sequence of Tulsi.

Other names: Ocimum sanctum, the wonder plant ‘Holy basil’

Significance of Tulsi:

- Worshipped for over more than 3000 years through the sacred traditions of Hindu culture
- **Medical benefits**
 - It used in several systems of traditional medicine, including Ayurveda, Greek, Roman, Siddha, and Unani.
 - It is used in the preparations to cure various diseases like bronchitis, bronchial asthma, malaria, diarrhoea, dysentery, skin diseases, arthritis, painful eye diseases, chronic fever, insect bite.

- It has also been described to possess anti-fertility, anti-cancer, anti-diabetic, anti-fungal, anti-microbial, hepatoprotective, cardioprotective, anti-emetic, anti-spasmodic, analgesic, adaptogenic and diaphoretic actions.

Significance of whole genome sequencing:

- It is first step to understand and unravel the secrets of this mother of all herbs.
- It will help in providing scientific validity to the traditional claims of its utility in diverse medicinal usage.
- This will also facilitate identification of not yet identified genes involved in the synthesis of important secondary metabolites in this plant.
- The development of molecular tools and genomic resources will accelerate molecular breeding and ultimately the utility of Holy basil in medical community.

5. TOPIC: IT AND COMPUTERS

5.1. INTERNET.ORG

Internet.org is a partnership between social networking service company Facebook and seven mobile phone companies (Samsung, Ericsson, MediaTek, Microsoft, Opera Software, Reliance and Qualcomm) that aims to bring affordable Internet access to everybody by increasing affordability, increasing efficiency, and facilitating the development of new business models around the provision of Internet access.

- Facebook announced a tie-up with Reliance Communications to launch Internet.org in India.
- India now becomes the sixth destination for Internet.org
- The service has already been launched in Zambia, Tanzania, Kenya, Colombia and Ghana.

Internet.org critics:

- The Internet.org model violates most definitions of net neutrality, as it provides access to a limited menu of services claiming to be the Internet
- The subscribers have no say in selecting the websites.
- The Internet ceases to be an open platform where everyone has an equal chance to succeed.
- In the long run, internet.org could present a huge competitive advantage to some, to the disadvantage of many.

FOR A FREE INTERNET

Panel says it "unhesitatingly recommends that the core principles of Net Neutrality must be adhered to"



MAIN PROPOSALS FLOATED BY GOVERNMENT COMMITTEE

- | | |
|--|--|
| <ul style="list-style-type: none"> ⊕ Controversial plans such as Airtel Zero be allowed with prior clearance from TRAI, but not platforms such as Internet.org of Facebook ⊕ Content and application providers such as Facebook "cannot be permitted to act as gatekeepers" and profit out of "network operations" ⊕ Over-the-top apps | <ul style="list-style-type: none"> should be actively encouraged as they enhance consumer welfare and increase productivity ⊕ Apps offering domestic calling should be brought under the regulatory framework prescribed for telecom operators ⊕ VoIP apps providing international calling services should be exempted from licensing requirements |
|--|--|

5.1.1. WHAT IS NET NEUTRALITY

It is a principle that Internet service providers should enable access to all content and applications regardless of the source, and without favouring or blocking particular products or websites. If ISPs reduces speed of content from some serve, or block content from some serves then it is against Net Neutrality.

Background:

- Globally, the debate has been on for a long time, but in India, Airtel triggered it last December by announcing plans to start charging subscribers for VoIP services such as Skype and Viber, which allows making calls using the Internet.
- While cellphone users came out against the move, telecom operators called for a level-playing field to run a “viable” business and demanded that same rule apply for same services, even VoIP.

Recommendations of DoT’s panel on net Neutrality:

5.2. MOOC

What are MOOCs (Massive open online courses):

- A massive open online course is an online course aimed at unlimited participation and open access via the web.

Indian govt. steps regarding MOOCs:

- Govt. (HRD ministry) launched the Study Webs of Active-Learning for Young Aspiring Minds (**SWAYAM**), a Web portal where Massive Open On-line Courses (MOOCs) will be available on all kinds of subjects.

Need of MOOCs:

- Poor learning standards among students
- A report by an online talent assessment company asserts that only 10 per cent of MBA graduated and 17 per cent of engineering graduates in India are employable.
- **Poor accessibility:** There is lack of quality education at basic levels and accessibility at later levels are the driving forces behind the ill statistics.

India has achieved near universal enrolment at elementary level and enhanced hard and soft infrastructure, the challenge lies in providing access to secondary and higher education to make the youth employable.

Opportunities:

Growth of information technology, increased internet user base, greater smart phone penetration and policies of government such as digital India, National optical fibre network provides immense opportunities to provide education and skill development via online platforms.

Impacts/Significance:

- Will help in skill development
- People who do not have chance to receive traditional college degrees from top institutions can now earn certificates from MOOCs offered by the world’s top institutions.
- Affordable form of education to get a job or improve in the job they have
- It has the potential to unlock a billion more brains to solve the world’s biggest problems.
- By providing free online courses on demand, MOOCs enable learners to learn from anywhere irrespective of their situation as long as they have internet access.

Criticisms:

- Digital literacy is necessary to make use of the online materials as India lags behind in digital literacy.
- Relying on user-generated content can create a chaotic learning environment.
- The time and effort required from participants may exceed what students are willing to commit to a free online course.

6. TOPIC: HEALTH

6.1. THREE-PARENT BABIES

- Britain became the first country to allow a “three-parent” IVF technique which doctors say will prevent some inherited incurable diseases.
- The treatment is known as “three-parent” in vitro fertilization (IVF) because the babies, born from genetically modified embryos, would have DNA from a mother, a father and from a female donor.
- Mitochondrial DNA (mDNA) is passed through the mother and mitochondrial diseases cause symptoms ranging from poor vision to diabetes and muscle wasting.

Concerns:

- The Church opposes the technique on the grounds that the manipulation of the nuclear DNA of two women and a man would create three-parent babies. This is against the nature.
- It is a step towards creating designer babies.
- Some raised concerns that the fertilisation process may cause inherited conditions such as fatal heart problems, liver failure, brain disorders, blindness and muscular dystrophy.

Mitochondrial donation how it works

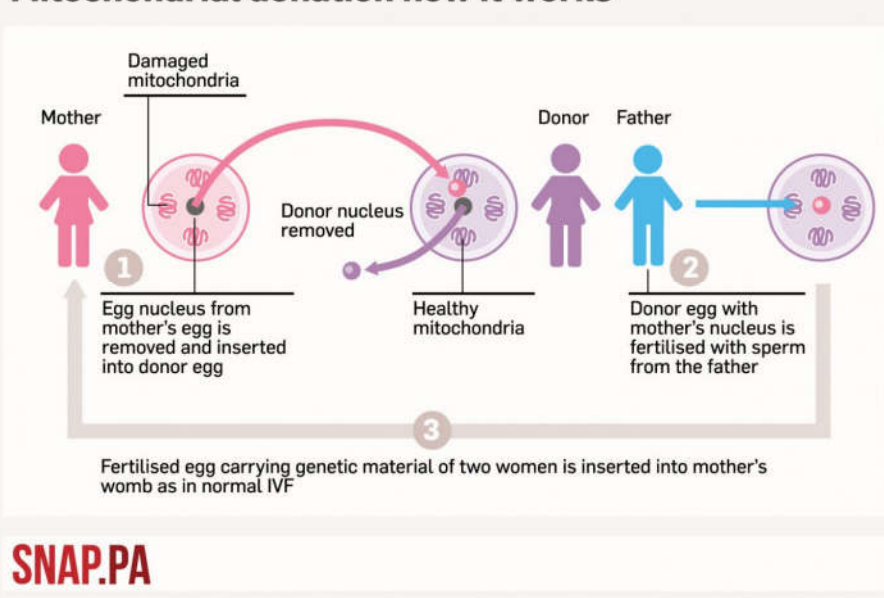

6.1.1. WHAT ARE MITOCHONDRIA?

Mitochondria are tiny organelles found in almost every cell in the body.

- They are known as the "powerhouse of the cell."
- They are responsible for creating more than 90 percent of cellular energy.
- They are necessary in the body to sustain life and support growth.
- They are composed of tiny packages of enzymes that turn nutrients into cellular energy.
- Mitochondrial failure causes cell injury that leads to cell death. When multiple organ cells die there is organ failure.

What is Mitochondrial Disease?

- Mitochondrial disease is a chronic, genetic disorder that occurs when the mitochondria of the cell fail to produce enough energy for cell or organ function.

HOW IT WORKS

- Capsules made using polymer with medicines in them
- Average capsule size is between 1 μm to 100 μm
- Tested successfully with ciprofloxacin (an antibiotic) and insulin (for treatment of diabetes)
- Capsule is then put in the wound, and shock waves release medicine slowly from the capsule
- Drug can be delivered in controlled doses
- Decrease in blood glucose seen in mice within 60 mins; capsules can be triggered for up to three days, reducing the number of injections needed by diabetics
- Microshock waves are produced when energy is released in a confined area suddenly
- The most commonly observed shockwave is that of a plane that has crossed the sound barrier
- The shock wave generator fits into a box that is less than 1-ft-long

Such remotely triggered drug delivery systems could increase patient compliance. It would be of great advantage in case of mentally disabled patients and children.

—DIPSHIKHA CHAKRAVORTY, Department of Microbiology and Cell Biology, IISc.

- Mitochondrial diseases are sometimes (about 15% of the time) caused by mutations in the mitochondrial DNA (mDNA) that affect mitochondrial function.

Mitochondrial DNA: Mitochondrial DNA is separate from DNA found in the cell nucleus and does not affect human characteristics such as hair or eye colour, appearance or personality traits.

An alternative to syringes for drug delivery:

Scientists at the Indian Institute of Science have successfully tested an alternative to syringes for drug delivery. They have designed a capsule loaded with medicine that is triggered by micro-shock waves.

How it works:

- The researchers designed tiny biocapsules made of a polymer (spermidine-dextran sulfate or Sper-DS). The capsules are so small that 10 of the biggest ones could be placed in a length of one millimetre.
- The capsules are loaded with either insulin or the antibiotic ciprofloxacin.
- They are then placed on the infection site — for instance, external diabetic wounds — and are triggered by micro-shock waves produced by a handheld machine.

Results:

- The result is that a controlled portion of the drug is released with every shock wave (on an average 20 per cent of the medicine is released with every wave). Almost 90 per cent of the drug release was observed when the particles were exposed to micro-shock waves five times.
- The method, tested on mice, delivers medicine through tiny capsules when triggered by a micro-shock wave.

Importance/benefits:

- It will prevent infections that are spread through contaminated, non-sterilised syringes.
- Each year, 1.3 million early deaths are caused by unsafe injections.
- Infections by bacteria such as Staphylococcus (cause of foot infections that people living with diabetes are susceptible to) are lethal as they form a biofilm around the protein in the cell. The shock waves tear this biofilm and aid the treatment.

6.2. PERSONALISED TB TREATMENT

The Chennai-based National Institute for Research in Tuberculosis (NIRT) will develop new diagnostic tools and new treatments to address the sharp rise in cases of multi-drug resistant tuberculosis (MTB).

- It will be done through whole genome sequencing of the TB bacterium to see the pattern of drug resistance in the community.
- Many patients with MDR-TB and XDR-TB (extensively drug-resistant tuberculosis (TB)) are resistant to second-line drugs.
- The new technology will help in finding out the mutations in a patient and decide a treatment that is tailor-made for him.
- MDR (multi drug resistant) TB is the name given to TB when the bacteria that are causing it are resistant to at least isoniazid and rifampicin, two of the most effective TB drugs.
- XDR TB (extensively drug resistant TB) is defined as strains resistant to at least rifampicin and isoniazid in

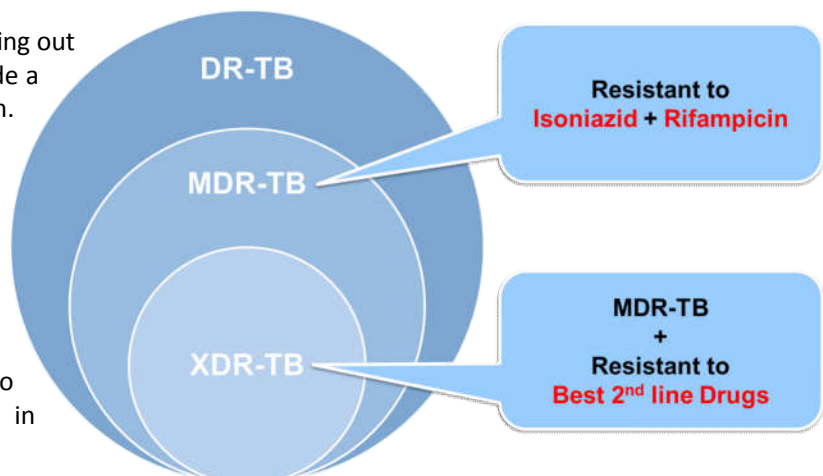

addition to being resistant to one of the fluoroquinolones, as well as resistant to at least one of the second line injectable TB drugs amikacin, kanamycin or capreomycin.³

- MDR TB and XDR TB do not respond to the standard six months of TB treatment with "first line" anti TB drugs, and treatment for them can take two years or more and requires treatment with other drugs that are less potent, more toxic and much more expensive. Worldwide only a few thousand patients with MDR TB and XDR TB are treated each year.

7. TOPIC: ENVIRONMENT

7.1. CARBON DIOXIDE FERTILIZATION

The enhancement of the growth of plants as a result of increase in the concentration of atmospheric CO₂. Depending on their mechanism of photosynthesis, certain types of plants are more sensitive to changes in atmospheric CO₂ concentration.

CO₂ absorption:

Tropical forests absorb 1.4 billion metric tonnes of carbon dioxide out of a total global absorption of 2.5 billion - more than what is absorbed by forests in Canada, Siberia and other northern regions, called boreal forests.

Forests and other land vegetation currently remove up to 30 percent of human carbon dioxide emissions from the atmosphere during photosynthesis.

A new NASA-led study says that Tropical forests may be absorbing far more carbon dioxide in response to its rising atmospheric levels than many scientists thought.

7.2. PLANT PROTECTION CODE (PPC)

Plant Protection Code (PPC), a set of guidelines for regulating the chemical inputs in tea cultivation, was rolled out on January 1, 2015. The aim is to make Indian tea a safe and healthy drink.

- The PPC is a comprehensive document, which deals with safe usage of crop protection products and methodologies that would be followed to reduce pesticide residues in tea.
- The code encourages tea growers to critically review their plant protection formulations (PPF), which are a list of chemicals that are used in tea.
- The code is based on the Codex **Alimentarius**, which is **a set of international food standards and guidelines**.
- PPF covers insecticides, fungicides, herbicides and bio pesticides.

The PPF, evolved by Tea Board, has detailed the chemicals that can be used in tea plantations making some exceptions for South India. It said that chemical use should be restricted not only in tea estates, but also near water bodies, wildlife habitats and human dwelling to check contamination.

Tea Board noted that in spite of using PPFs, the tea industry loses nearly 30 per cent of its crop due to pests, weeds and diseases.

7.3. THE MENACE OF PLASTIC WASTE

Plastic waste is one type of municipal solid waste that has become ubiquitous in India and most developing countries. Much of it is not recycled, and ends up in landfills or as litter on land, in waterways and the ocean.

Important findings of study:

- For the first time, researchers have estimated that eight million tonnes of plastic being dumped into the oceans by 192 coastal countries in 2010.
- Researchers have identified the top 20 countries that have dumped the most plastic waste into the oceans.
- At twelfth position, India is one of the worst performers. It has dumped up to 0.24 million tonnes of plastic into the ocean every year; the amount of mismanaged plastic waste per year is 0.6 million tonnes.
- In the case of China, the No. 1 polluter, the coastal population sends up to 3.53 million tonnes of plastic waste into the oceans each year.
- Annual input into the oceans is set to double by 2025



Implications:

- An unknown quantity of degraded plastic in the form of particles enters the food chain. Besides affecting marine life, plastic that gets into the food chain has serious health implications for humans.
- Debris in the ocean, such as plastic and glass, has been having a life-threatening global impact on marine life
- Instances of fish and bird entanglement

Way forward:

- A two-pronged approach has to be adopted to reduce per capita plastic waste generation and cut the amount of mismanaged waste by employing better waste management practices.
- Recycling is the best available way to tackle the waste.

Cutting down on the use of plastic should also begin in earnest, and the first item that has to be targeted is the single-use plastic bag.

7.4. NATIONAL AIR QUALITY INDEX (AQI)

- The government launched the National Air Quality Index (AQI) that will put out **real time** data about the **level of pollutants** in the air and **inform people about the possible impacts on health**.
- Initially it will be launched for **10 cities**. The aim was to eventually deploy the index in all cities with a population of over one million.

Impacts: The Air Quality Index may prove to be a major impetus to improving air quality in urban areas, as it **will improve public awareness** in cities to take steps for air pollution mitigation.

Characteristics:

- The AQI is a global standard.
- The central agencies have taken into account eight pollutants: PM2.5, PM10, nitrogen oxides, sulphur dioxide, ozone, carbon monoxide, ammonia and lead while calculating and releasing the AQI.
- It will have 'one number, one colour and one description' to inform the public about air quality in a simple and easily understandable format.
- The index, using continuous 24-hour average data, will be made available daily from various monitoring stations in those cities.

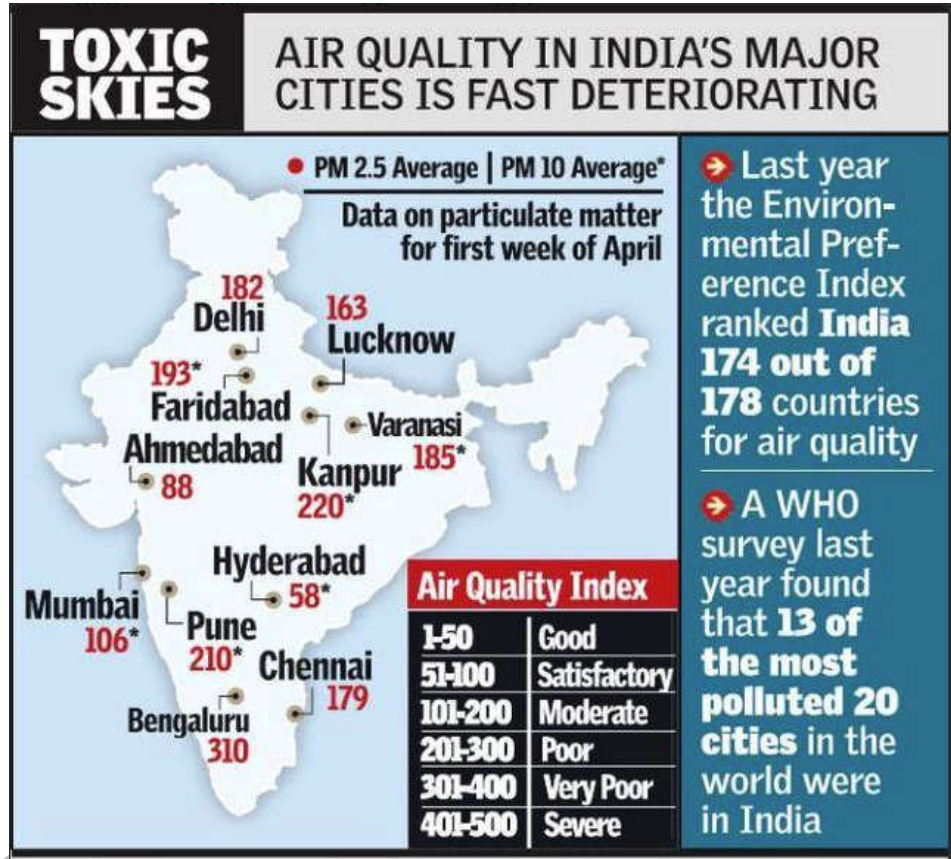

AQI	Remark	Color Code	Possible Health Impacts
0-50	Good	Green	Minimal impact
51-100	Satisfactory	Light Green	Minor breathing discomfort to sensitive people
101-200	Moderate	Yellow	Breathing discomfort to the people with lungs, asthma and heart diseases
201-300	Poor	Orange	Breathing discomfort to most people on prolonged exposure
301-400	Very Poor	Red	Respiratory illness on prolonged exposure
401-500	Severe	Dark Red	Affects healthy people and seriously impacts those with existing diseases

Analysis:

- Government has taken good initiative to monitor air pollution in real time. It will help citizens to take preventative measures while going out. But this step is not enough; still we don't have mechanism or measures in place to bring down peak pollution levels.

- Air Quality Index needs to be matched with actionable plans on how to bring the pollution levels down. In many countries AQI data leads to certain action to bring down pollution
 - ✓ Beijing for instance, puts in motion a slew of operations when the warning signal for severe pollution is issued. On such days' kindergartens, primary and middle schools close, there is a cap on the number of cars allowed on the roads and polluting factories either cut down emissions or shut down completely.
 - ✓ Similarly, when the air quality index rose in Paris recently, the city made public transport free and removed almost 50 per cent of the vehicles off the road.

7.5. INCINERATOR TECHNOLOGY FOR PRODUCING REFUSE DERIVED FUEL (RDF)

Why in news: National Green Tribunal (NGT), New Delhi, **has permitted the States, including Karnataka, to use incinerator technology** for producing Refuse Derived Fuel (RDF), commonly known as waste-to-energy.

Incineration:

- **Incineration** is a waste treatment process that involves the **combustion of organic substances** contained in waste materials.
- Incineration of waste materials converts the waste into **ash, flue gas, and heat.**
- Heat generated by incineration can be used to generate electric power.
- The gases, flue gases are **first treated for eradication of pollutants** before going in to atmosphere.
- Incinerators reduce the solid mass of the original waste by **95–96%.**

Concerns/ Arguments against Incineration:

- The highly toxic **fly ash, dioxin and furan emissions** may cause adverse health effect for local residents.
- Incinerators emit varying levels of heavy metals such **as vanadium, manganese, chromium, nickel, arsenic, mercury, lead, and cadmium**, which can be toxic at very minute levels.
- The **reusable, recyclable waste destroyed** in this process which has adverse impact on communities which are involved in recycling industries.

NGT order to minimize concerns:

- **No waste could be directly put into the incinerators** or for power generation, except the specifically permitted.
- Only those wastes that are found **unrecyclable** after segregation should be put into the incinerators.
- The tribunal emphasized that it was not putting any absolute restriction on RDF being used as power generation fuel, but first effort should be made for composting of wet waste.
- The States are free to use RDF for generating fuel with due care and caution by framing necessary guidelines.
- The Central Pollution Control Board and the Ministry of Environment and Forests were directed to prescribe **specific guidelines for emissions from incinerators.**

Refuse Derived Fuel (RDF):

- **Refuse-derived fuel (RDF) or solid recovered fuel/ specified recovered fuel (SRF)** is a fuel produced by shredding and dehydrating solid waste (MSW) with a Waste converter technology.
- RDF consists largely of **combustible components** of municipal waste such as plastics and biodegradable waste.
- RDF is extracted from municipal solid waste using a mix of mechanical and/or biological treatment methods.
- The production of RDF may involve the following steps:
 - ✓ Bag splitting/Shredding
 - ✓ Size screening
 - ✓ Magnetic separation
 - ✓ Coarse shredding
 - ✓ Refining separation

Applications of RDF:

- **Electricity production**
- Used alongside traditional sources of fuel in **coal power plants**
- **Cement kiln industry**
- Can also be fed into plasma arc gasification modules, pyrolysis plants and where the RDF is capable of being combusted cleanly or in compliance with the Kyoto Protocol.

7.6. INTERLINKING OF RIVERS

- Ministry of Water Resources, River Development & Ganga Rejuvenation has constituted a 'Task Force' on Interlinking of Rivers to look into the issues relating to Interlinking of Rivers (ILR) in the country. The Task Force would be chaired by B.N. Navalawala.
- B.N. Navalawala said the panel would work out a "mechanism" that will bring "benefits" to the surplus States when they shared waters with deficit regions.

Intra-basin transfer:

- Intra-basin transfer of waters was equally important. The rainfall distribution in the country, even within a State, was uneven.
- Therefore, while facilitating inter-linking of rivers, the task force would also look at intra-basin transfer.
- To start with, the Ken-Betwa link between Uttar Pradesh and Madhya Pradesh would be taken up. That would be followed by the Daman Ganga-Pinjar Par-Tapi-Narmada links between Maharashtra and Gujarat.
- The newly constituted Central task force on interlinking of rivers will focus on delivery of relief and rehabilitation (R&R) measures even before the links are implemented.
- For the remaining links, efforts would have to be made to win over Kerala, Odisha and Karnataka who were opposed to the programme.

The river linking project, which the National Water Development Agency (NWDA) calls inter-basin transfer of water, is designed to ease water shortages in western and southern India, while mitigating the impact of recurrent floods in the eastern parts of the Ganga basin.

The plan:

Under the National Perspective Plan (NPP) prepared by the Ministry of Water Resources, the NWDA has identified 14 links under the Himalayan Component and 16 links under the Peninsular Rivers Component.

- According to the NPP, the Himalayan Rivers

STATUS OF PROJECTS

STATUS OF INTER-LINKING OF RIVER (ILR) PROJECTS

➤ **Three out of 30 proposed ILR projects have so far got final nod for implementation**

➤ **Many proposals faced resistance from environmentalists and state governments**

STATES OPPOSED TO ILRS: Odisha, Kerala, Punjab and Himachal Pradesh

➤ **Except Punjab, the states which are opposed to the ILRs are ruled by non-NDA parties**



STATUS OF THE THREE WHICH HAVE GOT GREEN SIGNAL

➤ **Work on the Ken-Betwa ILR has already started** after completing the public hearing (taking public opinion) in MP and Uttar Pradesh

➤ **Govt takes final decision to begin work on 2 ILR projects** after approving their DPRs (detail project reports) and getting consent of Gujarat and Maharashtra

Development Project envisages construction of storage reservoirs on the main Ganga and the Brahmaputra and their principal tributaries in India and Nepal, along with an inter-linking canal system to transfer surplus flow of the eastern tributaries of the Ganga to the West. It will also link the main Brahmaputra with the Ganga.

- The Peninsular Rivers Development Component is divided into four major parts: interlinking of Mahanadi-Godavari-Krishna-Cauvery rivers and building storages at potential sites in these basins, interlinking West-flowing rivers north of Mumbai and south of the Tapi, interlinking of Ken-Chambal, and diversion of other West-flowing rivers.

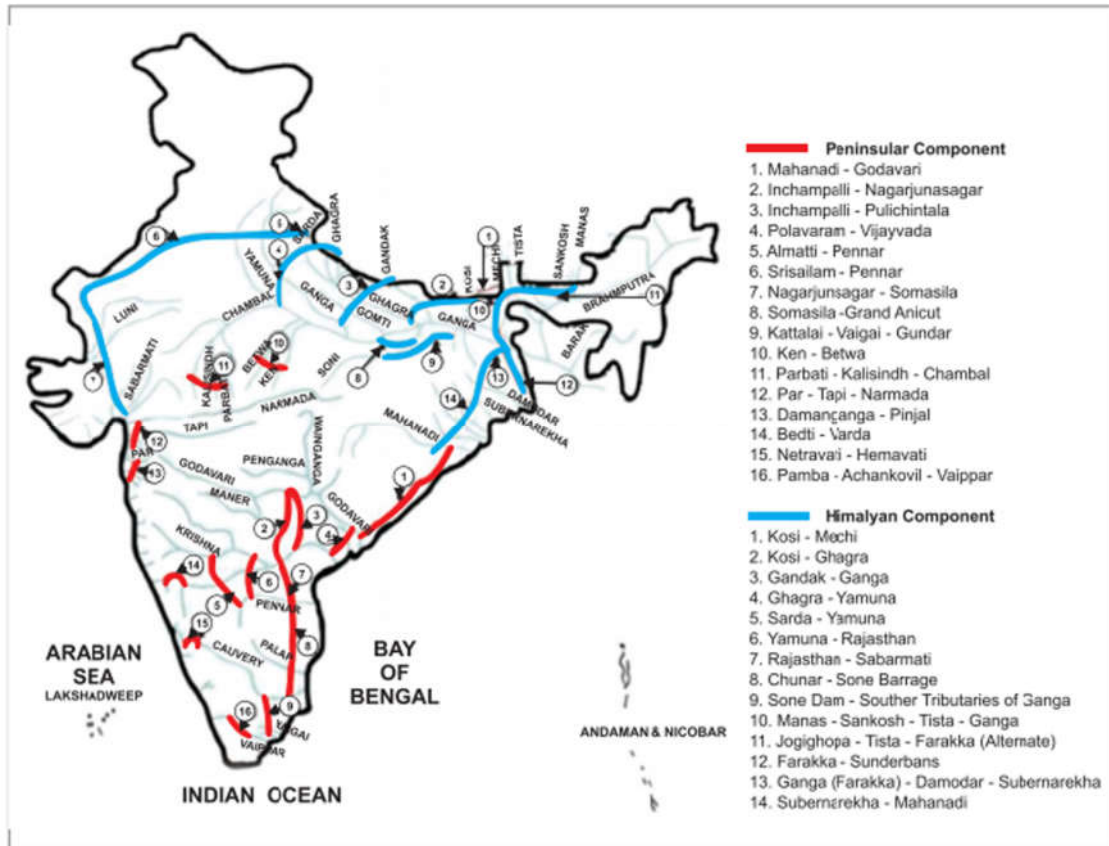

Issues with ILR:

- Environmentalists, hydrologists and economists around the world have expressed deep concerns at the irreversible damage that this sort of a mega project can do to the country's environment and our water resources.
- Massive civil works will be involved, lakhs of people will be uprooted and vast sums of money will be required.
- The idea of inter-basin transfers is based on the assumption that certain surplus (flood-prone) and deficit (drought-prone) areas exist so that water is readily available without any objection to transfer from the former to the latter.
- Any neat division between "deficit" and "surplus" areas becomes more of a problem in these times of climate change when erratic weather patterns are more frequently seen. So the basic conditions of problem-free transfer of water from the country's "surplus" to "deficit" areas simply do not exist. The tensions are likely to be much greater when inter-basin transfers also involve neighbouring countries.
- Bio-Diversity flourishing in a particular river system will react when it is linked to another river.

India's ambitious project remains divided between those who believe in its potential to generate power and provide irrigation and those who warn about its ecological consequences.

7.7. HEAT WAVE

Definition: A heat wave refers to a prolonged period of hot weather, which may be accompanied by high humidity. The **World Meteorological Organization (WMO)** defines a heat wave as **five or more consecutive days** in which the average daily maximum temperature is exceeded by **at least 5°C**, the normal period being 1961-1990.

Reasons for heat wave:

- A heat wave occurs when a system of high atmospheric pressure moves into an area. In such a high-pressure system, air from upper levels of our atmosphere is pulled toward the ground, where it becomes compressed and increases in temperature.
- This high concentration of pressure makes it difficult for other weather systems to move into the area, which is why a heat wave can last for several days or weeks. The longer the system stays in an area, the hotter the area becomes.
- The high-pressure inhibits winds, making them faint to non-existent. Because the high-pressure system also prevents clouds from entering the region, sunlight can become punishing, heating up the system even more.
- The combination of all of these factors come together to create the exceptionally hot temperatures we call a heat wave.

The deadliest heat wave on record in India is the 1998 one in which 2,541 people died. The most lethal heat wave in the world was the one that crippled Europe in 2003, killing 71,310 people.

KILLER SCORCHERS

		Year	Estimated deaths
1	Europe	2003	71,310
2	Russia	2010	55,736
3	Europe	2006	3,418
4	India	1998	2,541
5	India	2015	2,000+
6	US, Canada	1936	1,693
7	US	1980	1,260
8	India	2003	1,210
9	India	2002	1,030
10	Greece, Turkey	1987	1,030

Source: EM-DAT, CERD, Brussels

7.8. KONKAN RAILWAYS ENVIRONMENT FRIENDLY INITIATIVE

- Konkan Railway Corporation Ltd. (KRCL) has replaced power-guzzling high pressure sodium vapour (HPSV) lamps (70 watts) in its railway tunnels with light emitting diode (LED) lamps (24 watts).
- Each 24 Watt LED bulb would consume just one-third of the energy used by 70 Watt HPSV bulbs.
- More small initiatives have been taken by KRCL like phasing out all incandescent bulbs from railway premises and replacing them with more energy-efficient T5 fittings, and changing all resistance-type fan regulators to electronic ones.
- Konkan Railway has switched over to green energy with the installation of solar plants at Ratnagiri and Karmali stations and installing solar geysers at all its running rooms and rest houses.
- It has also taken up planting saplings in a big way on an annual basis along the entire rail route which has given it a unique identification as "Garden Railway".

A sodium-vapour lamp is a gas-discharge lamp that uses sodium in an excited state to produce light. There are two varieties of such lamps: low pressure and high pressure. Low-pressure sodium lamps are highly efficient electrical light sources, but their yellow light restricts applications to outdoor lighting such as street lamps. High-pressure sodium lamps have a broader spectrum of light than the low-pressure lamps, but still poorer colour rendering than other types of lamps. Low-pressure sodium lamps only give monochromatic yellow light and so inhibit colour vision at night.

What is a T5 tubelight?

T12, T8 and T5 are naming convention for tubelights where “12” is the thickest and “5” is the slimmest tubelight. T12s were quite popular in the past (some 10-15 years back). They were replaced with slimmer T8 version, which are the most popular and easily available version today. But T5 is the most efficient (energy saving) option that is available in the market today. It is approximately as thick as a thumb. As this is a relatively new technology, you may find it difficult to get them in the market.

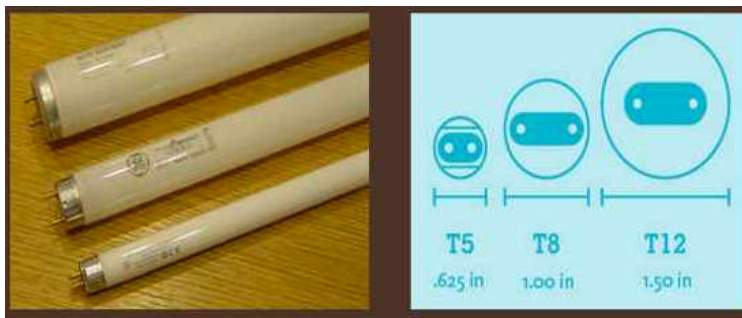

7.9. MERCURY POLLUTION

Sources:

- Burning coal for power and heat a major source of mercury.
- Mercury is contained in many products, including: batteries, measuring devices, such as thermometers and barometers, electric switches and relays in equipment, lamps (including some types of light bulbs), dental amalgam (for dental fillings), skin-lightening products and other cosmetics, pharmaceuticals.

Impact:

- Mercury is considered by WHO as one of the top ten chemicals or groups of chemicals of major public health concern.
- Exposure to mercury – even small amounts – may cause serious health problems, and is a threat to the development of the child in utero and early in life.
- Mercury may have toxic effects on the nervous, digestive and immune systems, and on lungs, kidneys, skin and eyes.
- Skin rashes and dermatitis; mood swings; memory loss; mental disturbances; and muscle weakness
- Symptoms include these: tremors; emotional changes (e.g., mood swings, irritability, nervousness, excessive shyness); insomnia; neuromuscular changes (such as weakness, muscle atrophy, twitching); headaches; disturbances in sensations; changes in nerve responses; performance deficits on tests of cognitive function. At higher exposures there may be kidney effects, respiratory failure and death.

Ex-workers of the thermometer-manufacturing unit of Hindustan Unilever Ltd. (HUL) in Kodaikanal, Tamil Nadu have been demanding justice.

Minamata Convention on Mercury:

The Convention obliges government Parties to take a range of actions, including addressing mercury emissions to air and to phasing-out certain mercury-containing products.

7.10. KASTURIRANGAN REPORT ON WESTERN GHATS

The government has said that as per the Kasturirangan report, commercial mining and polluting industries would be strictly banned in areas identified as eco sensitive zones.

Recommendations:

- The Kasturirangan panel has sought to balance the two concerns of development and environment protection.

- The Kasturirangan panel was set up to study the Gadgil committee report on the Western Ghats.
- The Gadgil panel report had faced unanimous opposition from state governments for recommending that almost three-fourth of the hills, including plantations, cultivated lands and large habitations, be turned into a restricted development zone.
- The Kasturirangan report seeks to bring just 37% of the Western Ghats under the Ecologically Sensitive Area (ESA) zones — down from the 64% suggested by the Gadgil report.
- Recommended prohibition on development activities and commercial activities like mining, thermal power plants, polluting industries and large housing plans in Ecologically Sensitive Area (ESA) zones.
- The villages falling under ESA will be involved in decision making on the future projects. All projects will require prior-informed consent and no-objection from the gram sabha (village council) of the village.
- A complete ban on mining activity in this zone and current mining activities should be phased out within five years.
- It has not recommended a ban on hydroelectric projects in the zone, but put a regime of stricter clearances for dams and other projects.
- For dams, it has demanded an uninterrupted ecological flow of at least 30% level of the rivers flow. Also, not more than 50% of the river basin should be affected at any time.
- It has also favoured a new authority to regulate the region's development and economic growth.

Criticisms:

- Kerala and Maharashtra have been particularly opposed to the Kasturirangan report, arguing it will seriously hamper development projects and hit livelihood prospects.
- Many saw the Kasturirangan report as a serious dilution of the original Gadgil report on the Western Ghats.

7.11. NATIONAL RENEWABLE ENERGY BILL, 2015

Objectives:

- To consolidate the renewable energy sector and give it an institutional structure.
- It also aims to set up dedicated renewable electricity investment zones.

Provisions:

- After it is passed by Parliament it would enable a National Renewable Energy Policy, Renewable Energy Corporation of India, an advisory group and a committee on the same.
- Till now, the renewable energy sector was governed by the **Electricity Act 2003**, which is also undergoing amendments.
- The law would cover all aspects of the renewable energy supply chain.
- The corporation would support project development and the advisory group will suggest amendments in the law and the policy from time to time.
- The various segments, which are the focus of the policy, are: Renewable energy resource assessment, technical and safety standards, monitoring and verification, manufacturing and skill development and data management.

Significance:

- Through a separate law, MNRE (Ministry of National Renewable Energy) would get freedom to execute projects and not depend on other ministries and departments for necessary clearances.
- The government has already announced scaling up of renewable power generation to 1.75 lakh GW by 2022 – out of which solar power alone is envisaged at 100 GW.
- The law makes it clear who will finance, who will plan and monitor and what support will come from where.
- The MNRE would work with its nodal agencies and state governments to enforce the mandated **Renewable Purchase Obligation** through appropriate mix of incentives, penalties, and legal action as defined in National RE Policy and Plan.

- The Bill would be placed in Parliament next year.

National Renewable Energy Fund:

Purpose:

To financially support the sector and the projects, the central government would set up a **'National Renewable Energy Fund'** and also push states to set up their own **'State Green Funds'**.

The fund may be used for supporting all the objectives of this Act, such as, but not limited to, R&D, resource assessment, demonstrations and pilot projects, low cost financing, investments for skills development, supporting RE technology manufacturing, infrastructure development, promoting all forms of decentralised renewable energy etc. provided such activities are selected in a transparent manner, and in line with the provisions of the National RE Policy/Plan.

Adding Muscle to the green force

Ministry of National Renewable Energy to have overarching powers

State governments to manage & finance respective projects

National Renewable Energy Policy: umbrella policy for all RE initiatives across the country

National Renewable Energy Committee: enable inter-ministerial coordination relating to the implementation of the Act

National Renewable Energy Advisory Group: technology watch group, utilisation of funds and the Central government on effective implementation of RE Act

Renewable Energy Corporation of India: act as a national level RE procurement entity and support development of 'Renewable Energy Investment Zones' across the country

National Renewable Energy Fund by the central government, State Green Funds by state nodal agencies

Copyright © by Vision IAS

All rights are reserved. No part of this document may be reproduced, stored in a retrieval system or transmitted in any form or by any means, electronic, mechanical, photocopying, recording or otherwise, without prior permission of Vision IAS.